

Features

- 1008 size
- Available in E12 series
- High Q
- High operating temperature of 125 °C
- RoHS compliant*

Applications

- Mobile phones
- Cellular phones
- CTV, VCR, HIC, FDD

CW252016 Series - High Q Chip Inductors

Electrical Specifications

Bourns® Part No.	Inductance		Q	Test Freq. (MHz)		SRF (MHz)	RDC (Ohms)		I _{rms} (mA)
	nH	Tol. %		Min.	L		Q	Min.	
CW252016-10NK	10	±10	50	50	500	4100	0.08	1000	
CW252016-12NK	12	±10	50	50	500	3300	0.09	1000	
CW252016-15NK	15	±10	50	50	500	2500	0.10	1000	
CW252016-18NK	18	±10	50	50	350	2500	0.11	1000	
CW252016-22NK	22	±10	55	50	350	2400	0.12	1000	
CW252016-27NK	27	±10	55	50	350	1600	0.13	1000	
CW252016-33NK	33	±10	60	50	350	1600	0.14	1000	
CW252016-39NK	39	±10	60	50	350	1500	0.15	1000	
CW252016-47NK	47	±10	65	50	350	1500	0.16	1000	
CW252016-56NJ	56	±5	65	50	350	1300	0.18	1000	
CW252016-68NJ	68	±5	65	50	350	1300	0.20	1000	
CW252016-82NJ	82	±5	60	50	350	1000	0.22	1000	
CW252016-R10J	100	±5	60	25.2	350	1000	0.56	650	
CW252016-R12J	120	±5	60	25.2	350	950	0.63	650	
CW252016-R15J	150	±5	45	25.2	100	850	0.70	580	
CW252016-R18J	180	±5	45	25.2	100	750	0.77	620	
CW252016-R22J	220	±5	45	25.2	100	700	0.84	500	
CW252016-R27J	270	±5	45	25.2	100	600	0.91	500	
CW252016-R33J	330	±5	45	25.2	100	570	1.05	450	
CW252016-R39J	390	±5	45	25.2	100	500	1.12	470	
CW252016-R47J	470	±5	45	25.2	100	450	1.19	470	
CW252016-R56J	560	±5	45	25.2	100	415	1.33	400	
CW252016-R68J	680	±5	45	25.2	100	375	1.55	400	
CW252016-R82J	820	±5	45	25.2	100	350	2.30	180	
CW252016-1R0J	1000	±5	35	25.2	50	290	1.75	370	
CW252016-1R2J	1200	±5	35	7.96	50	250	2.00	310	
CW252016-1R5J	1500	±5	28	7.96	50	200	2.30	330	
CW252016-1R8J	1800	±5	28	7.96	50	160	2.60	300	
CW252016-2R2J	2200	±5	28	7.96	50	160	2.80	280	
CW252016-2R7J	2700	±5	22	7.96	25	140	3.20	290	
CW252016-3R3J	3300	±5	22	7.96	25	110	3.40	290	
CW252016-3R9J	3900	±5	20	7.96	25	100	3.60	260	
CW252016-4R7J	4700	±5	20	7.96	25	50	4.00	260	

General Specifications

Temperature Rise 15 °C max. at rated current
 Operating Temperature -40 °C to +125 °C
 Storage Temperature -40 °C to +125 °C
 Reflow Soldering .. 230 °C, 50 sec. max.
 Resistance to Soldering Heat +260 °C, 5 seconds

Materials

Core Material
 -10NK thru -R82J Ceramic
 -1R0J thru -4R7J Ferrite
 Wire Enameled copper (1W1E180)
 Terminal Mo/Mn+Ni+Au
 Packaging 2,000 pcs. per reel

Product Dimensions

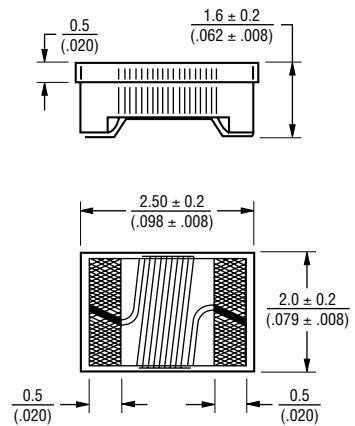

Typical Part Marking

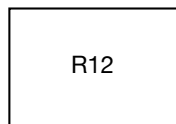

BOURNS®

Asia-Pacific:

Tel: +886-2 2562-4117
 Email: asiacus@bourns.com

Europe:

Tel: +36 88 520 390
 Email: eurocus@bourns.com

The Americas:

Tel: +1-951 781-5500
 Email: americus@bourns.com
 www.bourns.com

Recommended Layout

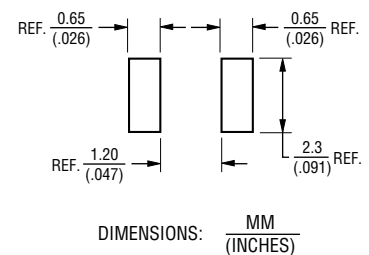

WARNING Cancer and Reproductive Harm
www.P65Warnings.ca.gov

*RoHS Directive 2002/95/EC Jan. 27, 2003 including annex and RoHS Recast 2011/65/EU June 8, 2011. Specifications are subject to change without notice. Users should verify actual device performance in their specific applications. The products described herein and this document are subject to specific legal disclaimers as set forth on the last page of this document, and at www.bourns.com/docs/legal/disclaimer.pdf.

CW252016 Series - High Q Chip Inductors

BOURNS®

Soldering Profile

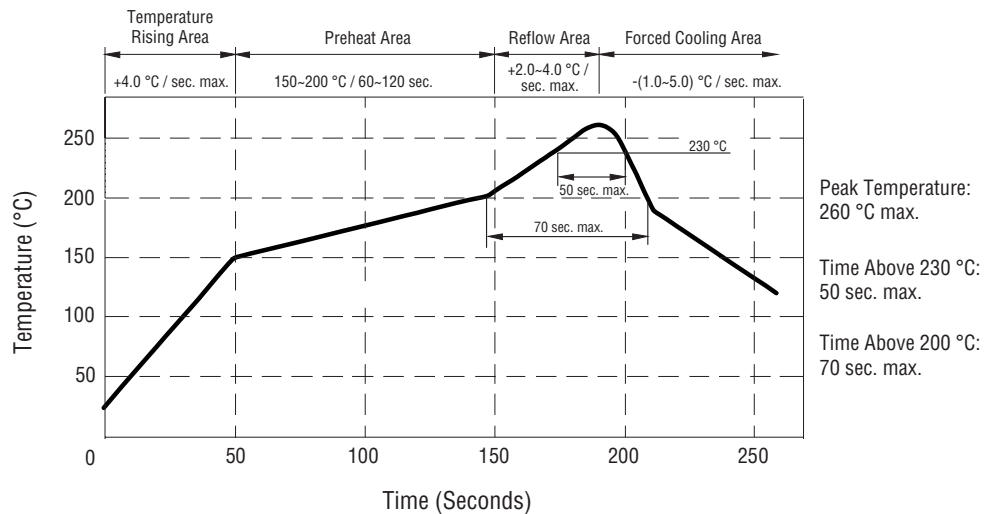

Packaging Specifications

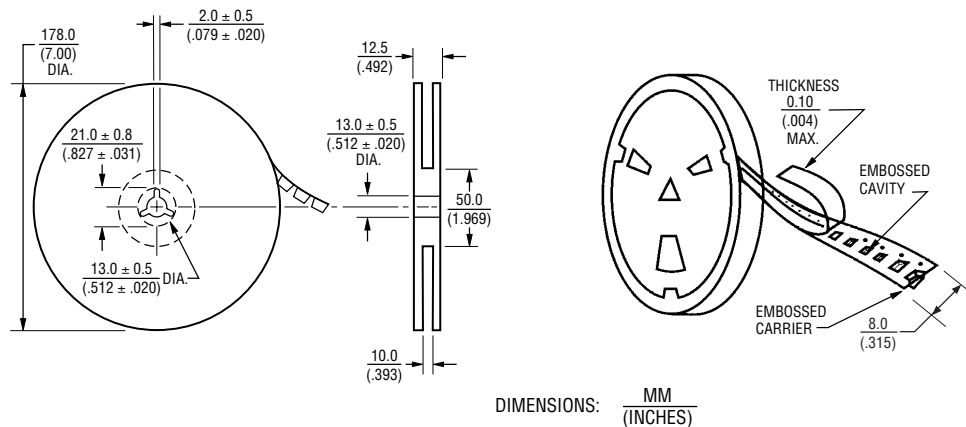

BOURNS®

Asia-Pacific: Tel: +886-2 2562-4117 • Email: asiacus@bourns.com

EMEA: Tel: +36 88 520 390 • Email: eurocus@bourns.com

The Americas: Tel: +1-951 781-5500 • Email: americus@bourns.com

www.bourns.com

REV. 01/17

Specifications are subject to change without notice.

Users should verify actual device performance in their specific applications.

The products described herein and this document are subject to specific legal disclaimers as set forth on the last page of this document, and at www.bourns.com/docs/legal/disclaimer.pdf.

This legal disclaimer applies to purchasers and users of Bourns® products manufactured by or on behalf of Bourns, Inc. and its affiliates (collectively, “Bourns”).

Unless otherwise expressly indicated in writing, Bourns® products and data sheets relating thereto are subject to change without notice. Users should check for and obtain the latest relevant information and verify that such information is current and complete before placing orders for Bourns® products.

The characteristics and parameters of a Bourns® product set forth in its data sheet are based on laboratory conditions, and statements regarding the suitability of products for certain types of applications are based on Bourns’ knowledge of typical requirements in generic applications. The characteristics and parameters of a Bourns® product in a user application may vary from the data sheet characteristics and parameters due to (i) the combination of the Bourns® product with other components in the user’s application, or (ii) the environment of the user application itself. The characteristics and parameters of a Bourns® product also can and do vary in different applications and actual performance may vary over time. Users should always verify the actual performance of the Bourns® product in their specific devices and applications, and make their own independent judgments regarding the amount of additional test margin to design into their device or application to compensate for differences between laboratory and real world conditions.

Unless Bourns has explicitly designated an individual Bourns® product as meeting the requirements of a particular industry standard (e.g., ISO/TS 16949) or a particular qualification (e.g., UL listed or recognized), Bourns is not responsible for any failure of an individual Bourns® product to meet the requirements of such industry standard or particular qualification. Users of Bourns® products are responsible for ensuring compliance with safety-related requirements and standards applicable to their devices or applications.

Bourns® products are not recommended, authorized or intended for use in nuclear, lifesaving, life-critical or life-sustaining applications, nor in any other applications where failure or malfunction may result in personal injury, death, or severe property or environmental damage. Unless expressly and specifically approved in writing by two authorized Bourns representatives on a case-by-case basis, use of any Bourns® products in such unauthorized applications might not be safe and thus is at the user’s sole risk. Life-critical applications include devices identified by the U.S. Food and Drug Administration as Class III devices and generally equivalent classifications outside of the United States.

Bourns expressly identifies those Bourns® standard products that are suitable for use in automotive applications on such products’ data sheets in the section entitled “Applications.” Unless expressly and specifically approved in writing by two authorized Bourns representatives on a case-by-case basis, use of any other Bourns® standard products in an automotive application might not be safe and thus is not recommended, authorized or intended and is at the user’s sole risk. If Bourns expressly identifies a sub-category of automotive application in the data sheet for its standard products (such as infotainment or lighting), such identification means that Bourns has reviewed its standard product and has determined that if such Bourns® standard product is considered for potential use in automotive applications, it should only be used in such sub-category of automotive applications. Any reference to Bourns® standard product in the data sheet as compliant with the AEC-Q standard or “automotive grade” does not by itself mean that Bourns has approved such product for use in an automotive application.

Bourns® standard products are not tested to comply with United States Federal Aviation Administration standards generally or any other generally equivalent governmental organization standard applicable to products designed or manufactured for use in aircraft or space applications. Bourns expressly identifies Bourns® standard products that are suitable for use in aircraft or space applications on such products’ data sheets in the section entitled “Applications.” Unless expressly and specifically approved in writing by two authorized Bourns representatives on a case-by-case basis, use of any other Bourns® standard product in an aircraft or space application might not be safe and thus is not recommended, authorized or intended and is at the user’s sole risk.

The use and level of testing applicable to Bourns® custom products shall be negotiated on a case-by-case basis by Bourns and the user for which such Bourns® custom products are specially designed. Absent a written agreement between Bourns and the user regarding the use and level of such testing, the above provisions applicable to Bourns® standard products shall also apply to such Bourns® custom products.

Users shall not sell, transfer, export or re-export any Bourns® products or technology for use in activities which involve the design, development, production, use or stockpiling of nuclear, chemical or biological weapons or missiles, nor shall they use Bourns® products or technology in any facility which engages in activities relating to such devices. The foregoing restrictions apply to all uses and applications that violate national or international prohibitions, including embargos or international regulations. Further, Bourns® products and Bourns technology and technical data may not under any circumstance be exported or re-exported to countries subject to international sanctions or embargoes. Bourns® products may not, without prior authorization from Bourns and/or the U.S. Government, be resold, transferred, or re-exported to any party not eligible to receive U.S. commodities, software, and technical data.

To the maximum extent permitted by applicable law, Bourns disclaims (i) any and all liability for special, punitive, consequential, incidental or indirect damages or lost revenues or lost profits, and (ii) any and all implied warranties, including implied warranties of fitness for particular purpose, non-infringement and merchantability.

For your convenience, copies of this Legal Disclaimer Notice with German, Spanish, Japanese, Traditional Chinese and Simplified Chinese bilingual versions are available at:

Web Page: <http://www.bourns.com/legal/disclaimers-terms-and-policies>

PDF: <http://www.bourns.com/docs/Legal/disclaimer.pdf>