

FILE NO.	FOT113,FOT115
PART NO.	-

REVISIONS				
REV.	DESCRIPTION	DATE	ECO No.	APPV'D
A	RELEASE TO PRODUCT	2010/11/05		CHANG

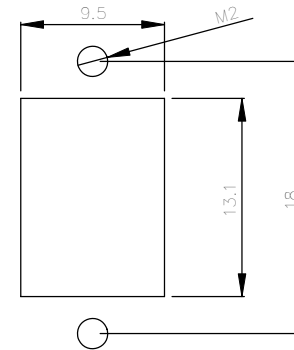
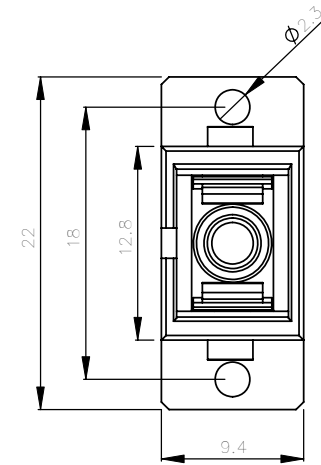
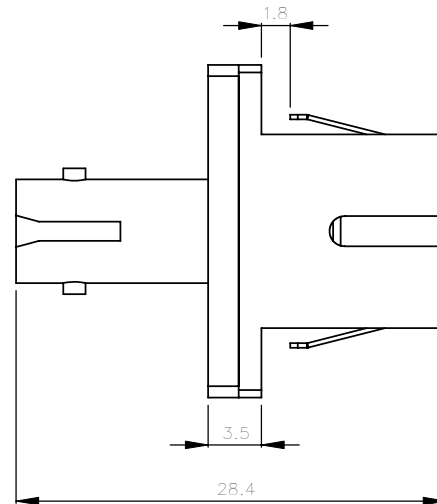
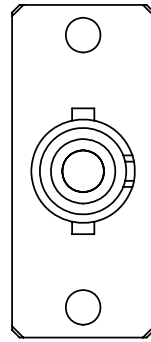

NOTES:
 1.INSERTION LOSS: 0.20dB /0.30dB (TYP./MAX.)
 2.RETENTION FORCE IS 200GF(1.96N)~600GF(5.88N).
 3.DURABILITY (500 MATINGS) 0.15dB MAX INCREASE.
 4.OPERATING TEMPERATURE -40° ~+80° C.
 5.HUMIDITY 95% R.H.(NON-CONDENSING).
 6.ALL MATERIAL COMPLIANT WITH RoHS.
 7.BLACK BOX P/N :
 S.M. ZrO2 : FOT113
 S.M. PhBr : FOT115

RECOMMENDED MOUNTING HOLE

MATERIAL	PBT		SIGNATURE	DATE	Another quality product from BLACK BOX <small>NETWORK SERVICES</small> 724-716-5500 • www.blackbox.com
QUANTITY		DRAWN	LU	2010/11/05	
		PROJECT ENGINEER	LU	2010/11/05	DWG. NAME
		CHECKED	LIU	2010/11/05	SIMPLEX ST-SC ADAPTER
		APPROVED	CHANG	2010/11/05	SIZE
		DRAWING MANAGER	CHUNG	2010/11/05	C
					DWG. NO.
					FOT113,FOT115
					REV.
					A
					SCALE : N/A
					2010/11/05
					SHEET 1 OF 1