

## AVD85B-48S12

**85 Watts**

**Sixteenth-brick Converter**

**Total Power:** 85 Watts  
**Input Voltage:** 36 to 75 Vdc  
**# of Outputs:** Single

### Special Features

- Delivering up to 7.1A output current
- Ultra-high efficiency 93% typ. at full load
- Wide input range: 36V ~ 75V
- Excellent thermal performance
- No minimum load requirement
- Basic isolation
- High power density
- Low output noise
- RoHS Directive(EU) 2015/863 (RoHS 3.0)
- Startup Pre-bias
- Remote control function
- Remote output sense
- Trim function: 80% ~ 110%
- Input under voltage lockout
- Output over current protection
- Output short protection
- Output over voltage protection
- Over temperature protection
- Industry standard sixteenth-brick pin-out outline
- SMT or through-hole option

### Safety

EN 62368-1  
CE Mark  
UL/TUV  
Materials meet UL94, V-0  
flammability rating  
EN55032 ClassA with external  
filter

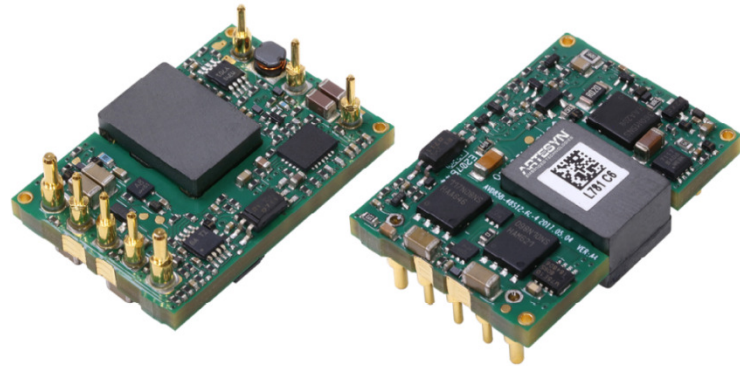

### Product Descriptions

The AVD85B-48S12 is a single output DC/DC converter with standard sixteenth-brick outline and pin configuration. It delivers up to 7.1A output current with 12V output voltage. Above 93% ultra-high efficiency and excellent thermal performance make it an ideal choice to supply power in telecom and datacom.

### Applications

Telecom/ Datacom

## Model Numbers

Standard	Output Voltage	Output Current	Structure	Remote ON/OFF logic	RoHS Status
AVD85B-48S12B-6L	12Vdc	7.1A	Baseplate	Negative	RoHS Directive(EU) 2015/863 (RoHS 3.0)
AVD85B-48S12-6L	12Vdc	7.1A	Open-frame	Negative	RoHS Directive(EU) 2015/863 (RoHS 3.0)
AVD85B-48S12B-6L-1	12Vdc	7.1A	Baseplate	Negative	RoHS Directive(EU) 2015/863 (RoHS 3.0)
AVD85B-48S12-6L-1	12Vdc	7.1A	Open-frame	Negative	RoHS Directive(EU) 2015/863 (RoHS 3.0)
AVD85B-48S12TL	12Vdc	7.1A	Open-frame	Negative	RoHS Directive(EU) 2015/863 (RoHS 3.0)

## Ordering information

AVD85B	-	48	S	12	P	B	-	6	L	-	1
①		②	③	④	⑤	⑥	⑦	⑧	⑨		⑩

①	Model series	AVD: high efficiency sixteenth brick series, 85: output power 85W
②	Input voltage	48: 36V ~ 75V input range, rated input voltage 48V
③	Output number	S: single output
④	Rated output voltage	12: 12V output
⑤	Remote ON/OFF logic	Default: negative logic; P: positive logic
⑥	Baseplate	B: with baseplate; default: open frame
⑦	-	Need "-" for through-hole unit, to separate the data of voltage and pin length, omit for SMT unit
⑧	Pin length	T: SMT; 6: 3.8mm ± 0.25mm pin length
⑨	RoHS status	Y: RoHS, R5; L: RoHS, RoHS Directive(EU) 2015/863 (RoHS 3.0)
⑩	PCB type	Default : ENIG ; 1 : Immersion Tin

## Options

None

## Electrical Specifications

### Absolute Maximum Ratings

Stress in excess of those listed in the “Absolute Maximum Ratings” may cause permanent damage to the power supply. These are stress ratings only and functional operation of the unit is not implied at these or any other conditions above those given in the operational sections of this TRN. Exposure to any absolute maximum rated condition for extended periods may adversely affect the power supply’s reliability.

Table 1. Absolute Maximum Ratings:

Parameter	Model	Symbol	Min	Typ	Max	Unit
Input Voltage Operating -Continuous Non-operating -100mS	All	$V_{IN,DC}$	-	-	80	Vdc
	All		-	-	100	Vdc
Ambient Operating Temperature	All	$T_A$	-40	-	+85	°C
Isolation Voltage <sup>1</sup> Input to output	All		-	-	2250	Vdc
Storage Temperature	All	$T_{STG}$	-55	-	+125	°C
Voltage at remote ON/OFF pin	All		-0.3	-	12	Vdc
Humidity (non-condensing) Operating Non-operating	All		-	-	95	%
	All		-	-	95	%

Note 1 - 1mA for 60s, slew rate of 1500V/10s

## Input Specifications

Table 2. Input Specifications:

Parameter	Conditions <sup>1</sup>	Symbol	Min	Typ	Max	Unit
Operating Input Voltage, DC	All	$V_{IN,DC}$	36	48	75	Vdc
Turn-on Voltage Threshold	$I_O = I_{O,max}$	$V_{IN,ON}$	31	-	36	Vdc
Turn-off Voltage Threshold	$I_O = I_{O,max}$	$V_{IN,OFF}$	30	-	35	Vdc
Lockout Voltage Hysteresis	$I_O = I_{O,max}$		1	-	3	V
Maximum Input Current	$I_O = I_{O,max}$ $V_{IN,DC} = 36V_{DC}$	$I_{IN,max}$	-	-	3.5	A
Recommended Input Fuse	Fast blow external fuse recommended		-	-	5	A
Recommended External Input Capacitance	Low ESR capacitor recommended	$C_{IN}$	100	-	-	uF
Input Reflected Ripple Current	Through 12uH inductor	$I_{IN,typ}$	-	25	-	mA
Operating Efficiency	$I_O = I_{O,max}$ $I_O = 50% * I_{O,max}$	$\eta$	-	93.3 90.5	-	%

Note 1 -  $T_a = 25\text{ }^\circ\text{C}$ , airflow rate = 400 LFM,  $V_{in} = 48\text{Vdc}$ , nominal  $V_{out}$  unless otherwise noted.

## Output Specifications

Table 3. Output Specifications:

Parameter	Conditions <sup>1</sup>	Symbol	Min	Typ	Max	Unit	
Factory Set Voltage	$V_{IN,DC} = 48V_{DC}$ $I_O = 50\% * I_{O,max}$	$V_O$	11.88	12	12.12	Vdc	
Output Voltage Line Regulation	All	$\pm\%V_O$	-	0.063	-	%	
		$\pm V_O$	-	7.5	-	mV	
Output Voltage Load Regulation	All	$\pm\%V_O$	-	0.063	-	%	
		$\pm V_O$	-	7.5	-	mV	
Output Voltage Temperature Regulation	All	$\%V_O$	-	-	0.02	$\%/^{\circ}C$	
Output Voltage Trim Range	All	$V_O$	9.6	-	13.2	V	
Output Ripple, pk-pk	Measure with a 1uF ceramic capacitor in parallel with a 10uF tantalum capacitor, 0 to 20MHz bandwidth	$V_O$	-	64	-	$mV_{PK-PK}$	
Output Current	All	$I_O$	0	-	7.1	A	
Output DC current-limit inception <sup>2</sup>	All	$I_O$	8	-	12	A	
$V_O$ Load Capacitance <sup>3</sup>	All	$C_O$	220	-	3300	uF	
$V_O$ Dynamic Response	Peak Deviation Settling Time	25%~50%~25% or 50%~75%~50% 25% load change slew rate = 0.1A/us	$\pm V_O$	-	60	-	mV
		25%~50%~25% or 50%~75%~50% 25% load change slew rate = 1A/us	$T_s$	-	50	-	uSec
			$\pm V_O$	-	70	-	mV
			$T_s$	-	100	-	uSec

Note 1 -  $T_a = 25^{\circ}C$ , airflow rate = 400 LFM,  $V_{in} = 48V_{dc}$ , nominal  $V_{out}$  unless otherwise noted.

Note 2 - Hiccup: auto-restart when over-current condition is removed.

Note 3 - High frequency and low ESR is recommended.

## Output Specifications

Table 3. Output Specifications, con't:

Parameter	Conditions	Symbol	Min	Typ	Max	Unit	
Turn-on transient	Rise time	$I_O = I_{O,max}$	$T_{rise}$	-	20	-	mS
	Turn-on delay time	$I_O = I_{O,max}$	$T_{turn-on}$	-	10	-	mS
	Output voltage overshoot	$I_O = 0$	$\%V_O$	-	-	5	%
Switching frequency	All	$f_{sw}$	-	350	-	kHz	
Remote ON/OFF control (positive logic)	Off-state voltage	All	-0.3	-	1.2	V	
	On-state voltage	All	3.5	-	12	V	
Remote ON/OFF control (Negative logic)	Off-state voltage	All	3.5	-	12	V	
	On-state voltage	All	-0.3	-	1.2	V	
Output over-voltage protection <sup>4</sup>	Static	$V_O$	14	-	16.8	V	
	Dynamic		14	-	17.0		
Output over-temperature protection <sup>5</sup>	All	T	-	120	-	°C	
Output over-temperature hysteresis	All	T	-	10	-	°C	
+ Sense	All	$\%V_O$	-	-	5	%	
- Sense	All	$\%V_O$	-	-	5	%	
MTBF <sup>6</sup>	Telcordia SR-332-2006; 80% load, 300LFM, 40 °C T <sub>A</sub>		-	2.0	-	10 <sup>6</sup> h	

Note 4 - Hiccup: auto-restart when over-voltage condition is removed.

Note 5 - Auto recovery. over-temperature protect(OTP) test point: see Figure 10 and Figure 11.

Note 6 - 300LFM, 40°C, 48Vdc input voltage, 80%\* $I_{O,max}$

## AVD85B-48S12 Performance Curves



Figure 1: AVD85B-48S12 Output Ripple Waveform  
 1uS/div  
 Ch 4:  $I_{IN}$  (20mA/div)

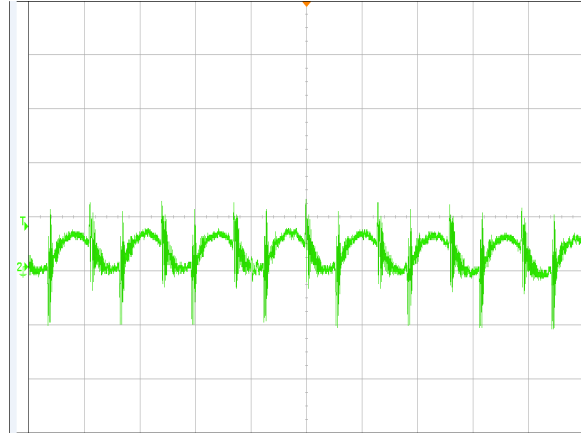

Figure 2: AVD85B-48S12 Input Reflected Ripple Current  
 2uS/div  
 Ch 2:  $V_O$  (10mV/div)

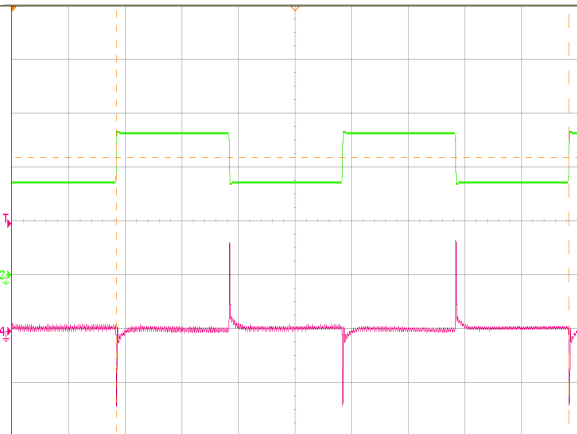

Figure 3: AVD85B-48S12 Output Voltage Dynamic Response  
 50% ~ 75% ~ 50%, 0.1A/uS slew rate, 2mS/div  
 Ch 2:  $I_O$  (2A/div) Ch 4:  $V_O$  (20mV/div)

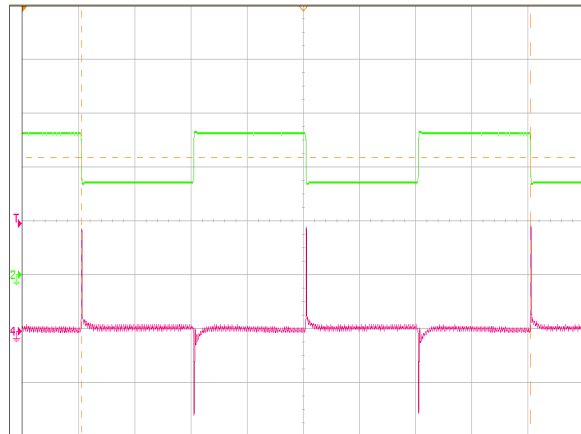

Figure 4: AVD85B-48S12 Output Voltage Dynamic Response  
 50% ~ 75% ~ 50%, 1A/uS slew rate, 2mS/div  
 Ch 2:  $I_O$  (2A/div) Ch 4:  $V_O$  (20mV/div)

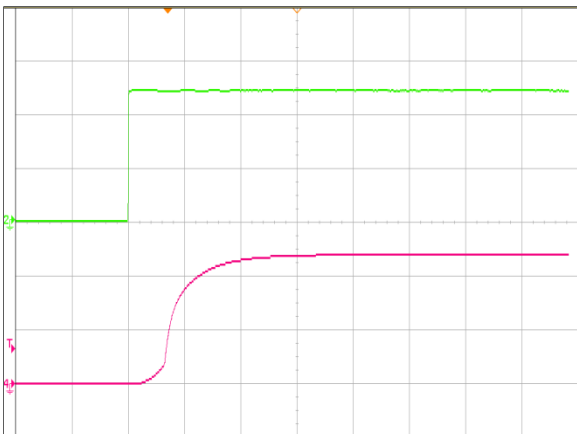

Figure 5: AVD85B-48S12 Output Voltage Start Up By Power On  
 $V_{IN} = 48Vdc$ ,  $I_O = I_{O,max}$ , 20mS/div  
 Ch 2:  $V_{IN}$  (20V/div) Ch 4:  $V_O$  (5V/div)

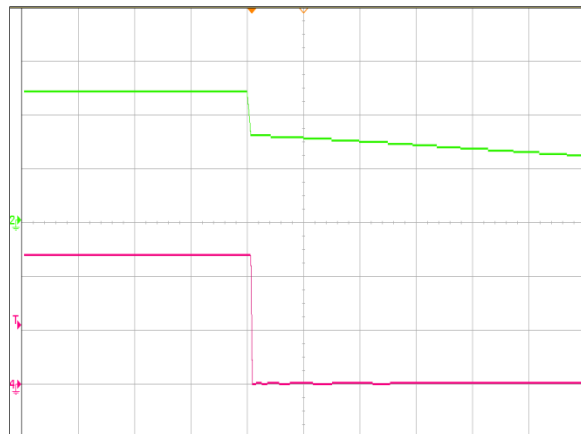

Figure 6: AVD85B-48S12 Output Voltage Shut Down By Power Off  
 $V_{IN} = 48Vdc$ ,  $I_O = I_{O,max}$ , 20mS/div  
 Ch 2:  $V_{IN}$  (20V/div) Ch 4:  $V_O$  (5V/div)

## AVD85B-48S12 Performance Curves

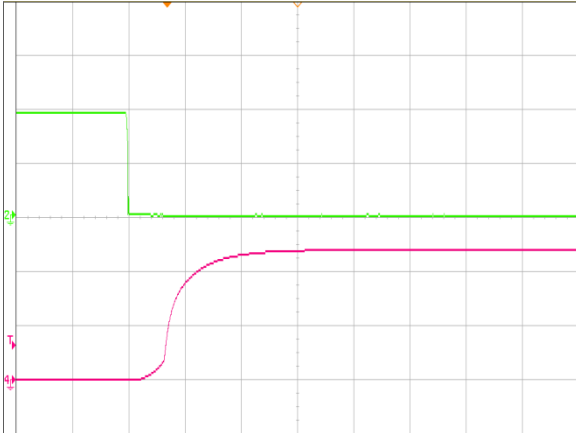

Figure 7: AVD85B-48S12 Output Voltage Start Up By Remote On  
 $V_{IN} = 48Vdc$ ,  $I_o = I_{o,max}$ , 20mS/div  
 Ch 2: Remote On (2V/div) Ch 4:  $V_o$  (5V/div)

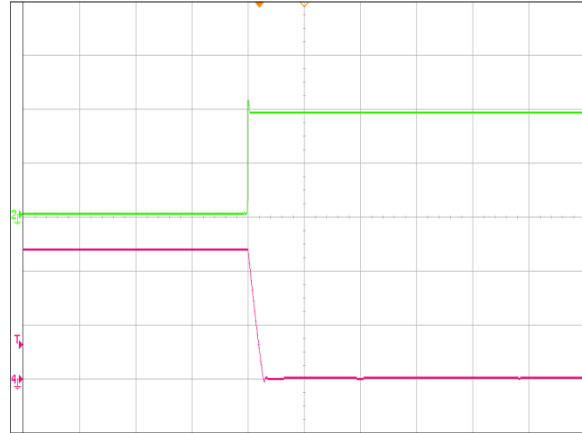

Figure 8: AVD85B-48S12 Output Voltage Shut Down By Remote Off  
 $V_{IN} = 48Vdc$ ,  $I_o = I_{o,max}$ , 10mS/div  
 Ch 2: Remote Off (2V/div) Ch 4:  $V_o$  (5V/div)

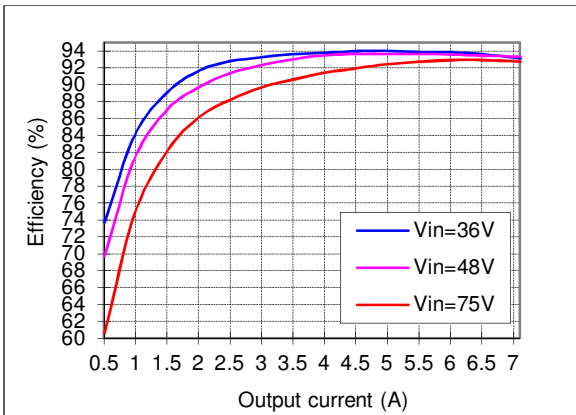

Figure 9: AVD85B-48S12 Efficiency Curves @ 25 °C, 400LFM  
 Loading:  $I_o = 10\%$  increment to 7.1A

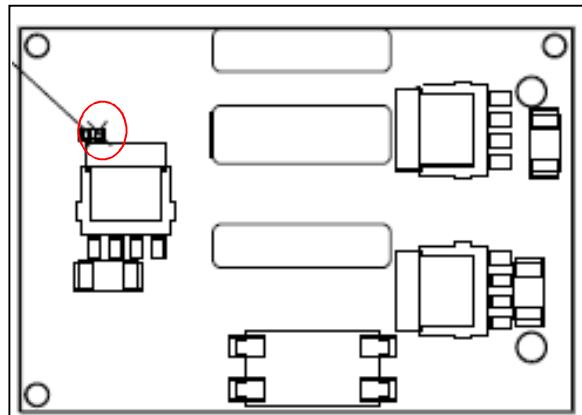

Figure 10: AVD85B-48S12 OTP test point (Open-frame module)

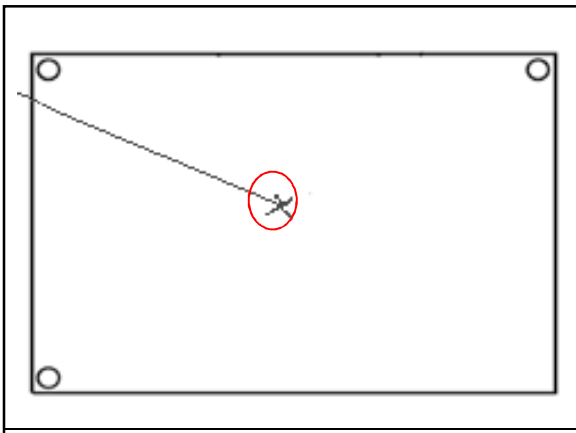
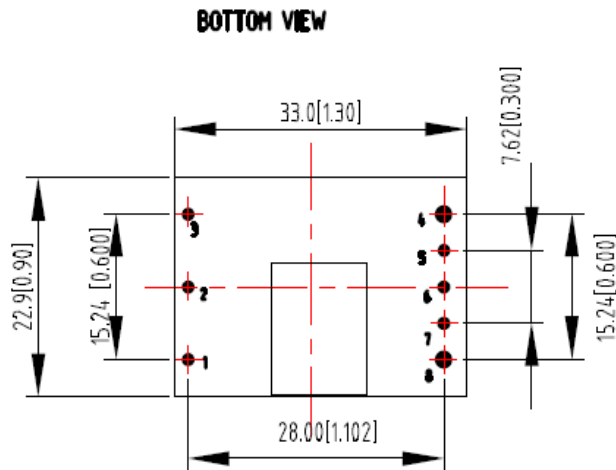

Figure 11: AVD85B-48S12B OTP test point (Module with baseplate)



## Mechanical Specifications

### Mechanical Outlines – Surface Mounted Module



SIDE VIEW

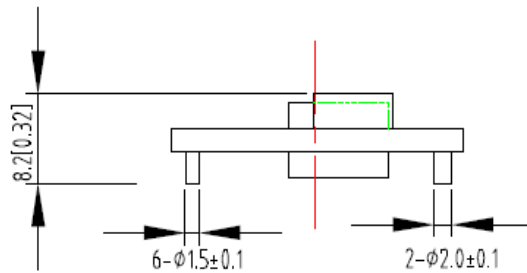

UNIT: mm[inch]

TOLERANCE: X.Xmm $\pm$ 0.5mm[X.XX in. $\pm$ 0.02in.]

X.XXmm $\pm$ 0.25mm[X.XXX in. $\pm$ 0.01in.]

Figure 12 Mechanical Outlines for Surface Mounted Module

## Mechanical Specifications

### Mechanical Outlines – Open Frame Module

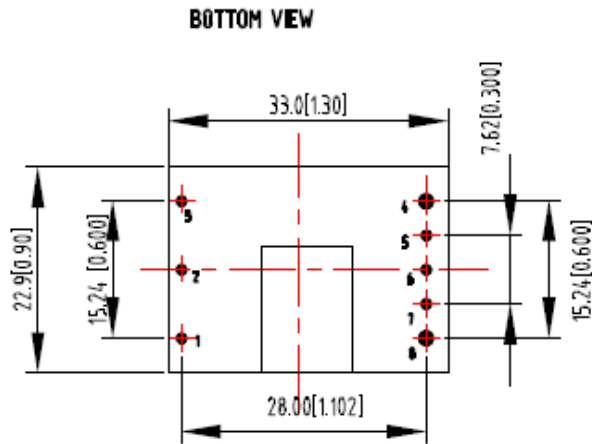

SIDE VIEW

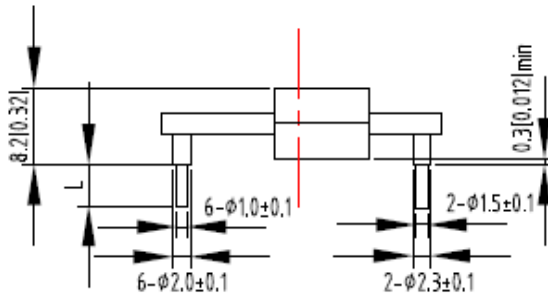

UNIT: mm[inch]

TOLERANCE: X.Xmm±0.5mm[X.XX in.±0.02in.]

X.XXmm±0.25mm[X.XXX in.±0.01in.]

Figure 13 Mechanical Outlines for Open Frame Module

## Mechanical Specifications

### Mechanical Outlines – Baseplate Module

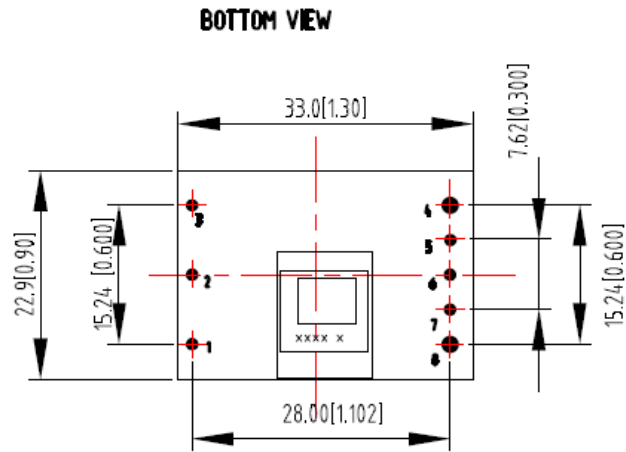

SIDE VIEW

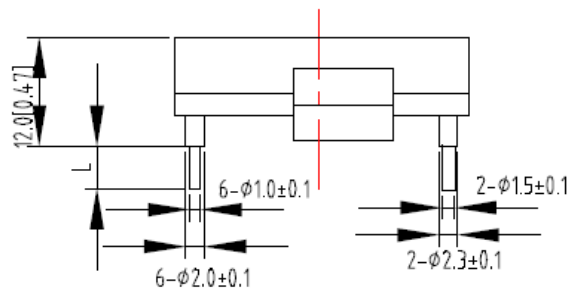

UNIT: mm[inch]

TOLERANCE: X.Xmm $\pm$ 0.5mm[X.XX in. $\pm$ 0.02in.]

X.XXmm $\pm$ 0.25mm[X.XXX in. $\pm$ 0.01in.]

Figure 14 Mechanical Outlines for Baseplate Module

## Pin Length Option

Device code suffix	L
-4	4.8mm ± 0.25 mm
-6	3.8mm ± 0.25 mm
-8	2.8mm ± 0.25 mm
None	5.8mm ± 0.25 mm

## Pin Designations

Pin No	Name	Function
1	Vin+	Positive input terminal
2	Remote On/Off	Remote control terminal
3	Vin-	Negative input terminal
4	Vo-	Negative output terminal
5	S-	Negative remote sense terminal
6	Trim	Output voltage trim terminal
7	S+	Positive remote sense terminal
8	Vo+	Positive output terminal

## Environmental Specifications

### EMC Immunity

AVD85B-48S12 series power supply is designed to meet the following EMC immunity specifications:

Table 4. Environmental Specifications:

Document	Description	Criteria
EN55032, Class A Limits	Conducted and Radiated EMI Limits, DC input port	/
IEC/EN 61000-4-2, Level 3	Electromagnetic Compatibility (EMC) - Testing and measurement techniques - Electrostatic discharge immunity test. Enclosure Port	B
IEC/EN 61000-4-6, Level 2	Electromagnetic Compatibility (EMC) - Testing and measurement techniques, Continuous Conducted Interference. DC input port	A
IEC/EN 61000-4-4, Level 3	Electromagnetic Compatibility (EMC) - Testing and measurement techniques, Electrical Fast Transient. DC input port.	B
IEC/EN 61000-4-5	Electromagnetic Compatibility (EMC) - Testing and measurement techniques, Immunity to surges - 600V common mode and 600V differential mode for DC ports	B
EN61000-4-29	Electromagnetic Compatibility (EMC) - Testing and measurement techniques, Voltage Dips and short interruptions and voltage variations. DC input port	B

Criterion A: Normal performance during and after test.

Criterion B: For EFT and surges, low-voltage protection or reset is not allowed. Temporary output voltage fluctuation ceases after disturbances ceases, and from which the EUT recovers its normal performance automatically. For Dips and ESD, output voltage fluctuation or reset is allowed during the test, but recovers to its normal performance automatically after the disturbance ceases.

## Safety Certifications

The AVD85B-48S12 series power supply is intended for inclusion in other equipment and the installer must ensure that it is in compliance with all the requirements of the end application. This product is only for inclusion by professional installers within other equipment and must not be operated as a stand alone product.

Table 5. Safety Certifications for AVD85B-48S12 series power supply system:

Document	File #	Description
UL/CSA 60950	E132002-A441-UL X13	US and Canada Requirements
EN 62368-1	B 013890 3165	European Requirements
CE	616	CE Marking

**Operating Temperature**

The AVD85B-48S12 series power supply will start and operate within stated specifications at an ambient temperature from -40 °C to 85 °C under all load conditions. The storage temperature is -55 °C to 125 °C.

**Thermal Considerations**

The converter is designed to operate in different thermal environments and sufficient cooling must be provided. Proper cooling of the DC/DC converter can be verified by measuring the temperature at the test point as shown in the Figure 15. The temperature at this point should not exceed the max values in the table 6.

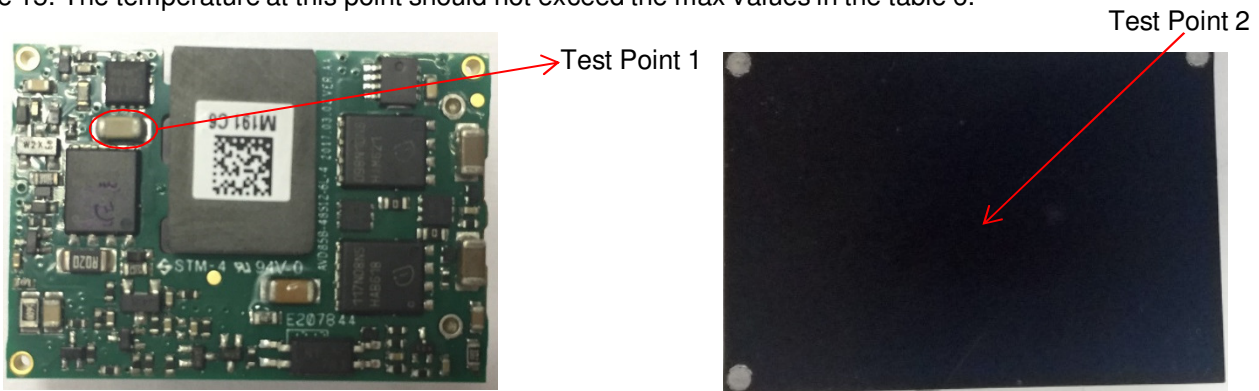

Figure 15 Temperature test point

Table 6. Temperature limit of the test point:

Test Point	Temperature Limit
Test point 1 (C3)	135°C
Test point 2 (Baseplate)	120°C

## Thermal Considerations – Con't

For a typical application, below are the derating curves show the derating of output current vs. ambient air temperature at different air velocity. The airflow direction is from Vin- to Vin+.

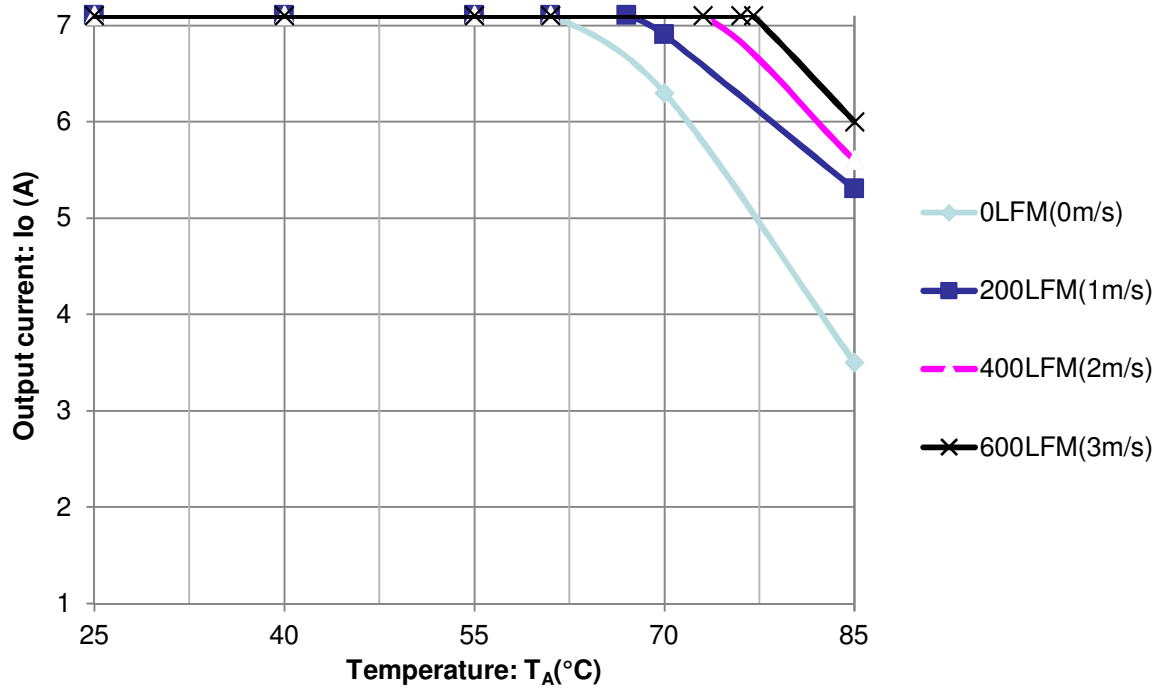

Figure 16 AVD85B-48S12-6L and AVD85B-48S12TL

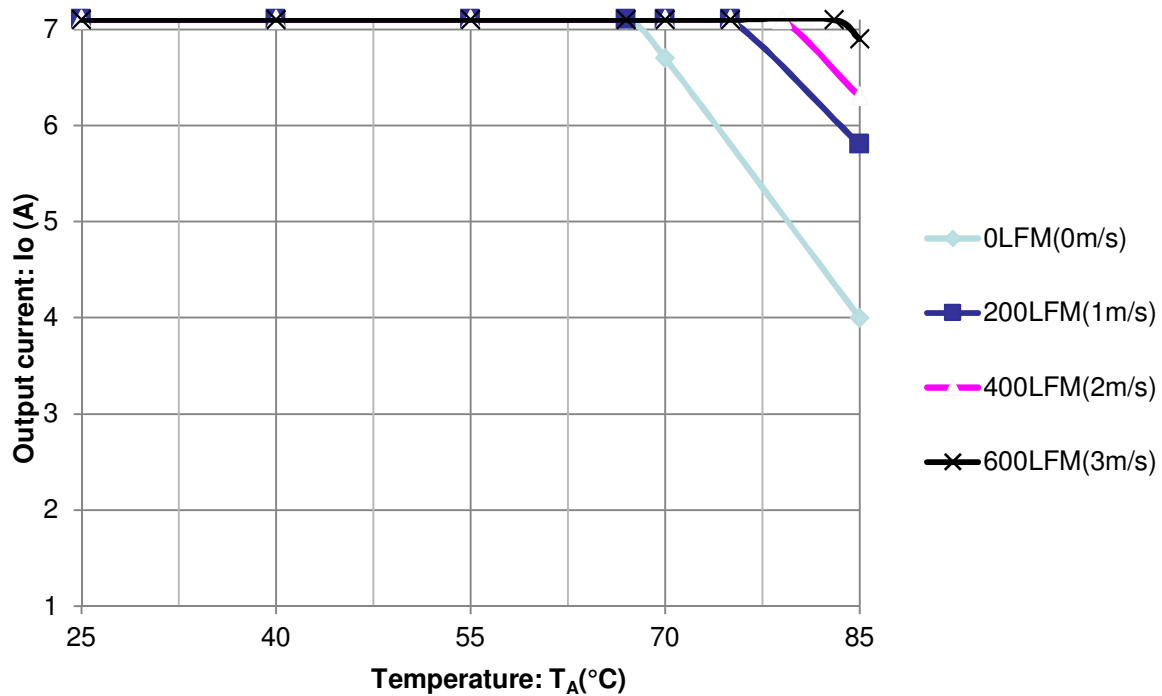

Figure 17 AVD85B-48S12B-6L



## Qualification Testing

Parameter	Unit (pcs)	Test condition
Halt test	4-5	$T_{a,min} - 20\text{ }^{\circ}\text{C}$ to $T_{a,max} + 25\text{ }^{\circ}\text{C}$ , $10\text{ }^{\circ}\text{C}$ step, $V_{in} = \text{min to max}$ , $0 \sim 100\%$ load
Vibration	3	Frequency range: $5\text{Hz} \sim 20\text{Hz}$ , $20\text{Hz} \sim 200\text{Hz}$ , A.S.D: $1.0\text{m}^2/\text{s}^3$ , $-3\text{db/oct}$ , axes of vibration: X/Y/Z. Time: 30min/axes
Mechanical Shock	3	30g, 6ms, 3axes, 6directions, 3time/direction
Thermal Shock	3	$-55\text{ }^{\circ}\text{C}$ to $125\text{ }^{\circ}\text{C}$ , unit temperature 20 cycles
Thermal Cycling	3	$-40\text{ }^{\circ}\text{C}$ to $55\text{ }^{\circ}\text{C}$ , temperature change rate: $1\text{ }^{\circ}\text{C}/\text{min}$ , cycles: 2cycles
Humidity	3	$40\text{ }^{\circ}\text{C}$ , 95%RH, 48h
Solder Ability	15	IPC J-STD-002C-2007

## Application Notes

### Typical Application

Below is the typical application of the AVD85B-48S12 series power supply.

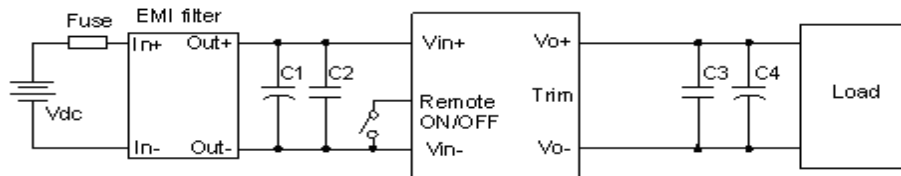

Figure 18 Typical application

C1: 220uF/100V electrolytic capacitor, P/N: UPM2A101MPD (Nichicon) or equivalent caps.

C2: 0.1uF/100V X7R ceramic capacitor, P/N: C3216X7R2A104KT0L0S (TDK) or equivalent caps.

C3: 1uF/100V X7R ceramic capacitor, P/N: C3216X7R2A105KT0L0U (TDK) or equivalent caps.

C4: 220µF oscon capacitor, P/N: CUXAE1C221M2BA (Sanyo).

Fuse: External fast blow fuse with a rating of 5A. The recommended fuse model is 0453005.MR from LITTLEFUSE.

EMI filter: see Figure 23.

48V input and full load output are default.

### Remote ON/OFF

Negative remote ON/OFF logic is available in AVD85B-48S12 series power supply. The logic is CMOS and TTL compatible. The voltage between pin Remote ON/OFF and pin Vin- must not exceed the range listed in table 3 to ensure proper operation. The external Remote ON/OFF circuit is highly recommended as shown in figure 19.

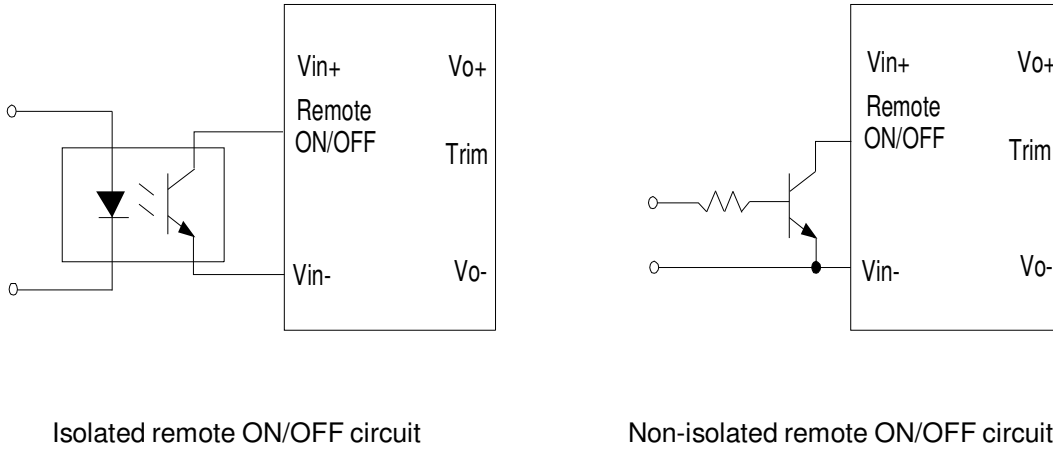

Figure 19 External Remote ON/OFF circuit

## Trim Characteristics

Connecting an external resistor between Trim pin and Vo- pin will decrease the output voltage. While connecting it between Trim and Vo+ will increase the output voltage. The following equations determine the external resistance to obtain the trimmed output voltage.

$$R_{adj-down} = \frac{510}{\Delta} - 10.2(K\Omega)$$

$$R_{adj-up} = \frac{5.1 \times V_{nom} \times (100 + \Delta)}{1.225 \times \Delta} - \frac{510}{\Delta} - 10.2(K\Omega)$$

$\Delta$ : Output rate against nominal output voltage.

$$\Delta = \left| \frac{100 \times (V_{nom} - V_o)}{V_{nom}} \right|$$

$V_{nom}$ : Nominal output voltage

For example, to get 13.2V output, the trimming resistor is

$$\Delta = \frac{100 \times (V_o - V_{o,nom})}{V_{o,nom}} = \frac{100 \times (13.2 - 12)}{12} = 10$$

$$R_{adj-up} = \frac{5.1 \times 12 \times (100 + 10)}{1.225 \times 10} - \frac{510}{10} - 10.2 = 488.35(K\Omega)$$

When trimming up, the output current should be decreased accordingly so as not to exceed the maximum output power.

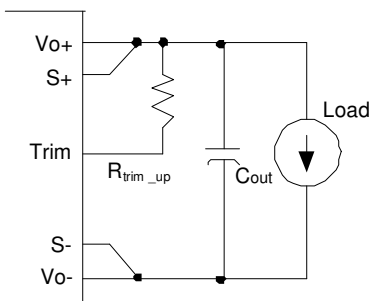

Figure 20 Trim up

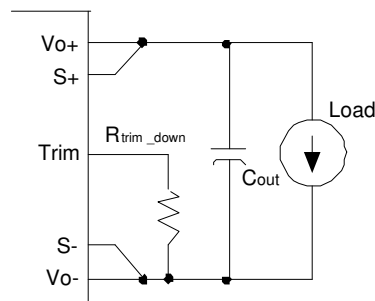

Figure 21 Trim down

If the sense compensate function is not necessary, connect S+ to Vo+ and S- to Vo- directly.

## Input Ripple & Output Ripple & Noise Test Configuration

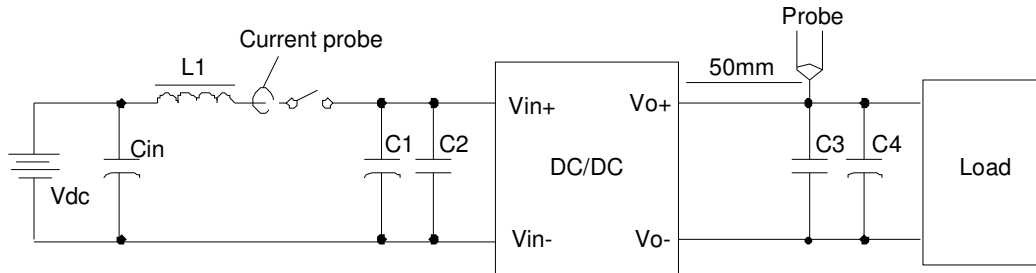

Figure 22 Input ripple & output ripple & noise test configuration

Vdc: DC power supply

L1: 12uH

Cin: 220uF/100V typical

C1 ~ C4: See Figure 18

Note - Using a coaxial cable with series 50ohm resistor and 0.68uF ceramic capacitor or a ground ring of probe to test output ripple & noise is recommended.

## EMC Test configuration

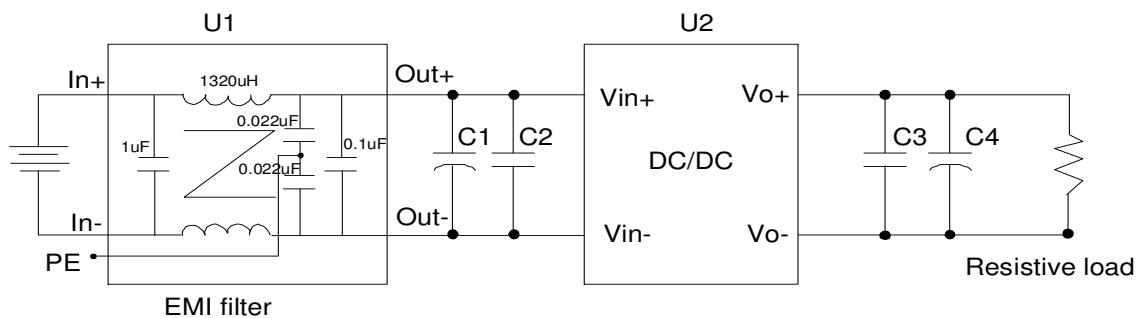

U1: Input EMC filter

U2: Module to test, AVD85B-48S12

C1 ~ C4: See Figure 18

Figure 23 EMC Test configuration

## Soldering

The product is intended for standard manual or wave soldering.

	Product Requirement	Product Name
RoHS Directive(EU) 2015/863 (RoHS 3.0)	Wave soldering	AVD85B-48S12B-6L AVD85B-48S12-6L

When wave soldering is used, the temperature on pins is specified to maximum 260 °C for maximum 7s.

When soldering by hand, the iron temperature should be maintained at 300 °C ~ 380 °C and applied to the converter pins for less than 10s. Longer exposure can cause internal damage to the converter. Cleaning of solder joint can be performed with cleaning solvent IPA or simulative.

The below products are intended for standard reflow soldering.

	Product Requirement	Product Name
RoHS Directive(EU) 2015/863 (RoHS 3.0)	Reflow soldering	AVD85B-48S12-6L AVD85B-48S12TL

When reflow soldering is used, Please refer to following fig for recommended temperature profile parameters.

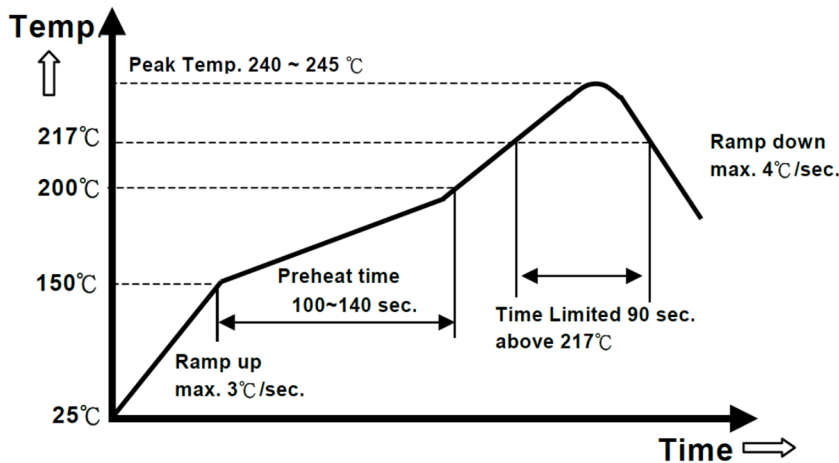

**Package Information**

**Package type**

moisture sensitivity level 3, moisture barrier bags.

**Minimal package QTY**

192 pcs.

**Package disassembly**

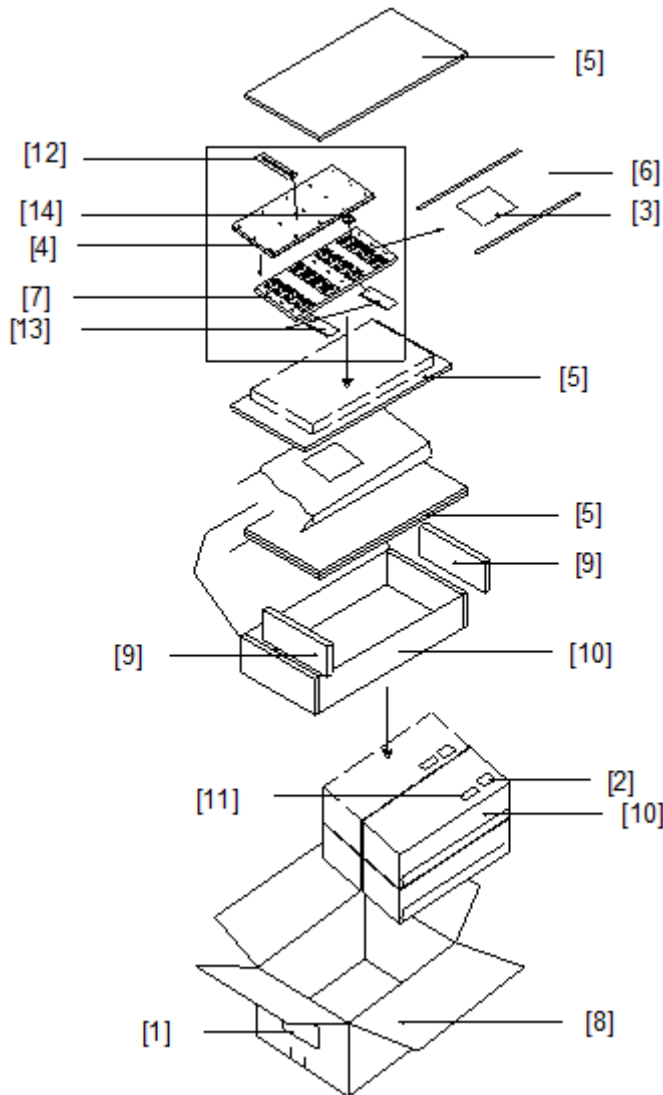
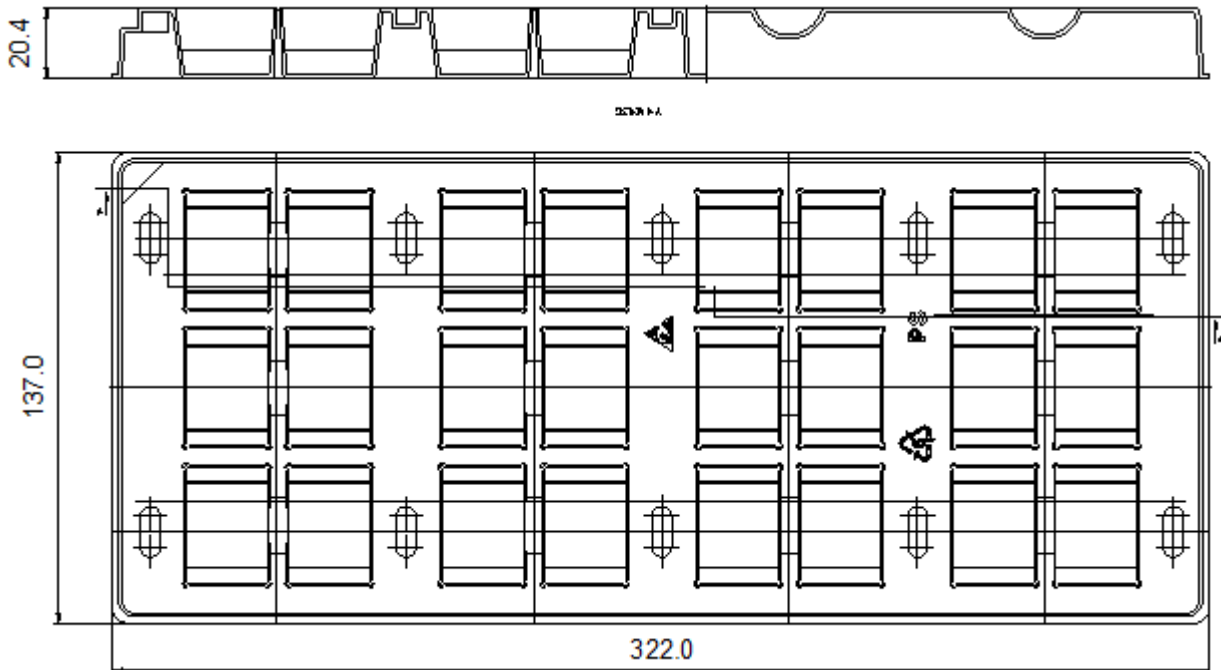

Figure 24 Package disassembly

Table 7. Assemblies description:

No.	Description
1	Shipping label
2	Moistureproof identification label
3	Moistureproof caution label
4	Tray cover
5	Anti-static PE foam 1
6	Moisture barrier bag
7	Tray
8	Shipping carton
9	Anti-static PE foam 2
10	Inner box
11	Model barcode label
12	Humidity indicating card
13	Desiccant
14	Model

## Package tray information





## Record of Revision and Changes

Issue	Date	Description	Originators
1.0	08.08.2017	First Issue	L. Leo
1.1	11.21.2017	Update the isolation voltage	L. Leo
1.2	07.10.2018	Update the trim error	K. Wang
1.3	12.09.2019	Update the soldering information	L. Leo
1.4	06.04.2019	Add Part Number "-1" Update Rohs	J. Ma
1.5	06.04.2020	Update the 62368 cert	L.Leo

### WORLDWIDE OFFICES

#### Americas

2900 South Diablo Way  
 Suite B100  
 Tempe, AZ 85282  
 USA  
 +1 888 412 7832

#### Europe (UK)

Ground Floor Offices  
 Barberrry House, 4 Harbour Buildings  
 Waterfront West, Brierley Hill  
 West Midlands, DY5 1LN, UK  
 +44 (0) 1384 842 211

#### Asia (HK)

14/F, Lu Plaza  
 2 Wing Yip Street  
 Kwun Tong, Kowloon  
 Hong Kong  
 +852 2176 3333



For more information: [www.artesyn.com](http://www.artesyn.com)  
 For support: [productsupport.ep@artesyn.com](mailto:productsupport.ep@artesyn.com)

Artesyn Embedded Technologies, Artesyn Embedded Power, Artesyn, and all Artesyn related logos are trademarks and service marks of Artesyn Embedded Technologies, Inc. All other names and logos referred to are trade names, trademarks, or registered trademarks of their respective owners. Specifications are subject to change without notice. © 2019 Artesyn Embedded Technologies, Inc. All rights reserved. For full legal terms and conditions, please visit [www.artesyn.com/legal](http://www.artesyn.com/legal).