



**Aero-Electric Connector**  
*Circular Connectors*



Military » Aerospace » Geophysical » Industrial » Transportation

[conesys.com](http://conesys.com)



With roots dating back to 1983, Conesys Inc. is focused on the Design and Manufacturing of Quality Interconnect Products. We are an ISO 9001 and AS9100- Certified vertically integrated manufacturer of Circular and Rectangular Connectors for the Military, Industrial, Transportation and Commercial Markets.

Our companies Design, Manufacture and supply High Performance, EMI Filter & Transient Devices, Copper & High Frequency Interconnect Systems, Hermetically Sealed, PCB, RF and Application – Specific Interconnects to a wide range of Military, Aerospace, Commercial Aviation, Heavy Equipment, Rail & Mass Transit, Geophysical and Machine Automation sectors.

We are committed to being a Global Interconnect Organization. Servicing our Customers throughout

the America's and Asia from our headquarters in Torrance, California, serving the needs of our European, African and Middle East Customers from our Conesys Europe facility in Toulouse, France and serving the local market in China from our Conesys Asia Ltd. facility in Beijing China.

Conesys Inc. combines excellent financial strength with the flexibility and responsiveness of an entrepreneurial firm to supply our valued Customers Quality Products, Cost-efficiency and On-Time Delivery, while meeting a full range of your requirements from Standard Applications to Customized Solutions Engineering.

Our Mission is to be a World-Class supplier of Electronic Connector Products through Customer Satisfaction, Quality, Innovation and Leading-Edge Technology.



**Conesys  
World Headquarters**



**Aero-Electric Connector**  
*A High Volume, Mil Spec  
Connector Manufacturer*



**Aero Industrial Products**  
*Manufacturer of Connectors  
and Cable Assemblies for the  
industrial marketplace*



**J-Tech & EMP**  
*Manufacturers of Custom  
Connectors, fiber optic  
assemblies, and filter connectors*



**Conesys Europe**  
*Sales, Engineering, and  
Connector Assembly of MIL Spec,  
Hermetic, and custom connectors,  
supporting  
International Customers*



**ATI Interco**  
*Sales and Engineering for  
Printed Circuit Board and  
Custom Connectors, Backshells  
and Cabling Components*



## Products

**Conesys/Aero Electric Connector** is a first-rate designer and cost competitive manufacturer of high performance environmental and firewall-rated cylindrical connectors machined from aluminum, carbon steel, stainless steel, and aluminum nickel bronze. **Conesys/J-Tech** specializes in front and rear release 5015 connectors as well as custom-specific applications for customized connectors and fiber optic assemblies. **Conesys/EMP Connectors** designs and manufactures EMI filter and EMP transient suppression devices. **Conesys Europe** markets and assembles product for Aero-Electric, J-Tech and EMP. **Conesys/Aero Industrial Products** sells and manufactures connectors and cable assemblies intended for the industrial marketplace.

## Markets

Our connectors are widely used in all types of applications spanning markets such as: Military/Aerospace, Commercial Aviation, Business Aviation, Aircraft Engines, Marine Applications, Heavy Equipment, Rail Mass Transit, Geophysical, Machine Automation/Motion Control, Medical Equipment, General Industrial and Telecommunications.

## Excellence

Conesys' manufacturing process is vertically integrated, ISO 9001:2008 and AS9100C: 2009 - 01 certified and most importantly focused on continuous improvement through prevention of defects and reduction in variation and waste.

## Quality Policy

"We are committed to Customer Satisfaction by meeting Quality and Delivery requirements while continuously measuring and improving our processes."

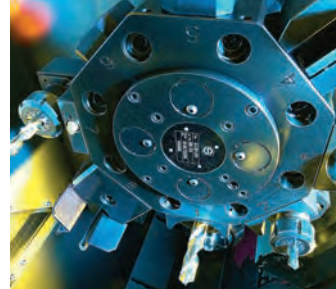

### Machining

*In house, using state-of-the-art double spindle, double turret CNC machines allowing for flexibility, and faster cycle times.*



### Molding

*In house, using internally built molds allowing for tighter controls and improved cycle times.*



### Plating

*In house, using state-of-the-art equipment and processes with environmentally friendly results.*

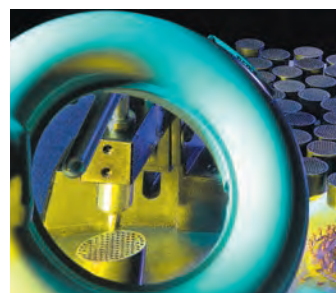

### Assembly

*In house, using cellular concepts for better efficiency, cost control and reduced cycle times.*

**Warranty:** Conesys warrants to the first user that it will correct any proven defect in product purchased from Conesys without charge. This correction will be by repair or replacement, F.O.B. factory. Correction will be made as long as product was used in accordance with good engineering practices. Any claims for warranty replacement must be made in writing within 365 days of the original delivery date. Claims made after this time will not be recognized. This warranty is in lieu of all other expressed or implied warranties, including warranties of merchantability, and it does not include consequential damages.

## X-line Multipin Connectors

The heavy duty X-line multi-pin series of connectors are environmentally sealed plugs and receptacles providing power for control and instrumentation connectivity across a wide spectrum of harsh environments. These devices are used in a variety of industrial applications, including onshore and offshore drilling operations, factories, refineries, marine, machine tool and land transportation applications.



## EN2997 Integrated Backshell

Coming soon, Conesys will be releasing our new ASD certified EN2997 Integrated Backshell connector. This innovative design eliminates the need for an additional backshell making it ideal for compact and lightweight applications. The EN2997 series offers improved high temperature, shock and vibration resistance combined with interfacial sealing. These environments are typically seen in aircraft engines, landing gear and sensor systems.



## MIL-DTL-26482 Series I Solder

Look for the new Conesys Aero Electric brand MIL-DTL-26482 series I solder cup connectors early 2015. By employing a proprietary insert molding technology we will achieve industry leading assembly performance, best in class sealing and contact alignment productivity. Available in both commercial and MIL versions, 26482 will also support MIL/Aero and the vast industrial markets that have adopted this product in factory automation, traffic signal, rail mass transit etc.



## MIL-DTL-38999 III Composite (Class M and J)

Having supplied Qualified D38999 series III class W, F, K, and S for decades, Aero Electric is expanding this product offering to include Qualified class M and J in 2015. The patented coupling mechanism will offer the first product of this kind to be free from metal components, which with other proprietary attributes to the product line, will make this the lightest D38999 III composite product in the market.



## Alternate Plating

Due for release early 2015, Conesys will launch its Aero Electric brand Class Z and Class T codes conforming to the latest D38999 series III specification. Along with Class Z and T, Black Nickel is already commercially available. All of these plating's are RoHS compliant, offer excellent electrically conductive, and meet the 500 hour salt spray testing for corrosion resistance.

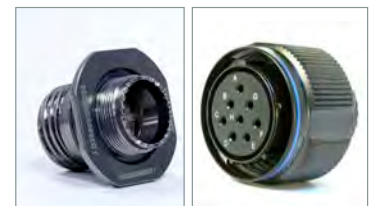

## EN3645

In 2015, Conesys will be releasing an ASD certified EN3645 connector. This is a subminiature circular connector series, compatible to the D38999 III connectors. These connectors offer the highest performance capabilities for both general duty and severe – high vibration- environment applications, including ground vehicles, airframe, and avionics communication systems.



**Aero-Electric Connector, Inc.**  
**Table of Contents**  
**Mil Spec Catalog (AE101)**



<b>38999 S I</b>	<b>MIL-DTL-38999 Series I</b> ..... <b>3-21</b>
	MS27466 (AE166) Front Wall Mount Receptacle ..... 6
	MS27656 (AE156) Rear Wall Mount Receptacle ..... 7
	MS27496 (AE196) Front Box Mount Receptacle ..... 8
	MS27505 (AE105) Rear Box Mount Receptacle ..... 9
	MS27468 (AE168) Jam Nut Receptacle ..... 10
	MS27467 (AE167) RFI Grounding Plug ..... 11
Dummy Stowage Receptacle (AE109) ..... 12	
<b>38999 S II</b>	<b>MIL-DTL-38999 Series II</b> ..... <b>.22 - 43</b>
	MS27472 (AE272) Front Wall Mount Receptacle ..... 25
	MS27497 (AE297) Rear Wall Mount Receptacle ..... 26
	MS27499 (AE299) Front Box Mount Receptacle ..... 27
	MS27508 (AE208) Rear Box Mount Receptacle ..... 28
	MS27513 (AE213) Front Box Mount Receptacle, Long Grommet ..... 29
	MS27474 (AE274) Jam Nut Receptacle ..... 30
	MS27473 (AE273) Straight Plug ..... 31
	MS27484 (AE284) RFI Grounding Plug ..... 32
	MS27500 (AE200) Plug with 90° Clamp ..... 33
Dummy Stowage Receptacle (AE210) ..... 34	
<b>38999 S III</b>	<b>MIL-DTL-38999 Series III</b> ..... <b>44-62</b>
	D38999/20 (AE320) Wall Mount Receptacle ..... 47
	D38999/24 (AE324) Jam Nut Receptacle ..... 48
	D38999/26 (AE326) Self-Locking, RFI Grounding Plug ..... 49
	Part Number Development Accessories ..... 54
	Dummy Stowage Receptacle (AE322) ..... 55
	Protective Cover, Plug (AE332) ..... 56
Protective Cover, Receptacle (AE333) ..... 57	
<b>5015 S III</b>	<b>MIL-DTL-5015 (Series III) Rear Release</b> ..... <b>63-87</b>
	MS3450 (AE550) Wall Mount Receptacle ..... 66
	MS3451 (AE551) Cable Connecting Receptacle ..... 67
	MS3452 (AE552) Box Mount Receptacle ..... 68
	MS3454 (AE554) Jam Nut Receptacle ..... 69
	MS3456 (AE556) Straight Plug ..... 70
	MS3459 (AE559) Self-Locking Plug ..... 71
	MS25042 (AE542) Protective Cover Plug ..... 73
MS25043 (AE543) Protective Cover Receptacle ..... 74	
<b>Integrated Rear Accessories</b>	<b>Integrated Rear Accessories</b> ..... <b>88-107</b>
	<b>MIL-DTL 5015 Series III</b>
	Wall Mount Receptacle (MS3450) ..... 89
	Jam Nut Receptacle (MS3454) ..... 90
	Straight Plug (MS3456) ..... 91
	<b>MIL-DTL 26482 Series II</b>
	Narrow Flange Receptacle (MS3470) ..... 93
	Cable Connecting Receptacle (MS3471) ..... 94
	Wide Flange Receptacle (MS3472) ..... 95
	Jam Nut receptacle (MS3474) ..... 96
	RFI Grounding Plug (MS3475) ..... 97
	Straight Plug (MS3476) ..... 98
	<b>MIL-DTL 38999 Series I</b>
	Integrated Rear Banding Platform (AE45-475) ..... 100
	Integrated Rear Banding Platform (AE45-476) ..... 101
	Integrated Rear Banding Platform (AE45-477) ..... 102
	Integrated Rear Banding Platform (AE45-478) ..... 103
	Integrated Rear Banding Platform (AE65-377) ..... 105
	Integrated Rear Banding Platform (Plug Connector, RFI) ..... 106
	Integrated Rear Banding Platform (AE65-379) ..... 107



**Aero-Electric Connector, Inc.**  
**Table of Contents**  
**Mil Spec Catalog (AE101)**



<p><b>MIL-DTL-26482 Series 2</b> ..... <b>108–126</b></p> <p>MS3470 (AE770) Narrow Flange Receptacle ..... 111</p> <p>MS3471 (AE771) Cable Connecting Receptacle ..... 112</p> <p>MS3472 (AE772) Wide Flange Receptacle ..... 113</p> <p>MS3474 (AE774) Jam Nut Receptacle ..... 114</p> <p>MS3476 (AE776) Straight Plug ..... 115</p> <p>MS3475 (AE775) RFI Grounding Plug ..... 116</p> <p>AC3475 Arctic Coupling Nut, RFI Plug ..... 117</p>	<b>26482 S II</b>
<p><b>MIL-DTL-83723 Series III</b> ..... <b>127–149</b></p> <p>M83723/71, 72 (AE83371, 72) Wall Mount Receptacle, Bayonet ..... 130</p> <p>M83723/73, 74 (AE83373, 74) Jam Nut Receptacle, Bayonet ..... 131</p> <p>M83723/75, 76 (AE83375, 76) Straight Plug, Bayonet ..... 132</p> <p>M83723/77, 78 (AE83377, 78) RFI Grounding Plug, Bayonet ..... 133</p> <p>M83723/82, 83 (AE83382, 83) Wall Mount Receptacle, Threaded ..... 135</p> <p>M83723/84, 85 (AE83384, 85) Jam Nut Receptacle, Threaded ..... 136</p> <p>M83723/86, 87 (AE83386, 87) Straight Plug, Threaded ..... 137</p> <p>M83723/91, 92 (AE83391, 92) RFI Grounding Plug, Threaded ..... 138</p> <p>M83723/95, 96 (AE83395, 96) Self-Locking Plug, Threaded ..... 139</p> <p>M83723/97, 98 (AE83397, 98) Self-Locking RFI Plug, Threaded ..... 140</p> <p>M83723/68, 69 (AE83368, 69) Lanyard Release Plug ..... 141</p> <p>M83723/70 (AE83370) Receptacle Adapter for Lanyard Release Plug ..... 142</p>	<b>83723 S III</b>
<p><b>MIL-DTL-26500</b> ..... <b>150–164</b></p> <p>MS24264R**B (AE664R**B) Wall Mount Receptacle, Bayonet ..... 153</p> <p>MS24265R**B (AE665R**B) Jam Nut Receptacle, Bayonet ..... 154</p> <p>MS24266R**B (AE666R**B) Straight Plug, Bayonet ..... 155</p> <p>MS24264R**T (AE664R**T) Wall Mount Receptacle, Threaded ..... 156</p> <p>MS24265R**T (AE665R**T) Jam Nut Receptacle, Threaded ..... 157</p> <p>MS24266R**T (AE666R**T) Straight Plug, Threaded ..... 158</p>	<b>26500</b>
<p><b>Printed Circuit Board Connectors</b> ..... <b>165–234</b></p> <p><b>MIL-DTL 38999 Series III</b></p> <p>Rear Wall Mount Receptacle (AEP65-101, AEP65-102) ..... 167</p> <p>Rear Wall Mount Receptacle (AEP65-103, AEP65-104) ..... 169</p> <p>Rear Wall Mount Receptacle (AEP65-105, AEP65-106) ..... 171</p> <p>Rear Jam Nut Receptacle (AE65-505) ..... 173</p> <p>Rear Jam Nut Receptacle (AE65-255) ..... 175</p> <p>Wall Mount Receptacle (AEP6520) ..... 177</p> <p>Single Hole Mount Receptacle (AEP6524) ..... 179</p> <p><b>MIL-DTL 38999 Series I</b></p> <p>Rear Wall Mount Receptacle (AEP45-101, AEP45-102) ..... 181</p> <p>Rear Wall Mount Receptacle Dual Flange (AEP45-103, AEP45-104) ..... 183</p> <p>Jam Nut Receptacle (AEP45-105, AEP45-106) ..... 185</p> <p><b>MIL-DTL 38999 Series II</b></p> <p>Rear Wall Mount Receptacle (AEP55-101, AEP55-102) ..... 187</p> <p>Rear Wall Mount Receptacle (AEP55-103, AEP55-104) ..... 189</p> <p>Rear Jam Nut Receptacle (AEP55-105, AEP55-106) ..... 191</p> <p>Insert Arrangements (MIL-DTL 38999 Series I, II, III) ..... 193</p> <p>Insert Arrangements (MIL-DTL 26482 Series II) ..... 215</p> <p>PC Tail Lengths (MIL-DTL 38999 Series I, II, III) ..... 229</p> <p><b>MIL-DTL 26482 Series II</b></p> <p>Wall Mount Receptacle (AEP15-101, AEP15-102) ..... 209</p> <p>Wall Mount Receptacle (AEP15-103, AEP15-104) ..... 211</p> <p>Jam Nut Receptacle (AEP15-105, AEP15-106) ..... 213</p>	<b>Printed Circuit Board Connectors</b>
<p><b>Cross Reference</b> ..... <b>235–240</b></p> <p><b>Glossary of Terms</b> ..... <b>241–243</b></p>	

# MIL-DTL-38999

## Features and Application

### Series I



38999 S I

## Features and Application

MIL-DTL-38999 Series I is a bayonet coupling subminiature configuration with high contact density, ideal for smaller wire gauge, general-purpose applications. These environment-resisting connectors are 100% “scoop-proof.” Pins are recessed in elongated shells to prevent the possibility of bending contacts when plugs are scooped into the mating receptacles.

This family of connectors is offered in 5 receptacle-mounting styles. They include square flange receptacles, for both front and rear panel (wall) mounting; square flange receptacles, for both front and rear box mounting; and jam nut receptacles which incorporate “O” ring seals, designed for rear panel “D” hole mounting.

Standard plugs provide RFI protection by incorporating a continuous strip of attached grounding fingers attenuating interference up to 1 GHz.

Fifty-seven insert arrangements per MIL-STD-1560 are tooled and qualified to MIL-DTL-38999 Series I, utilizing 2 to 128 contacts. Contacts come in sizes 22M, 22D, 20, 16, 12, and 8 (coax and twinax), terminating wire sizes from 28 gauge to 12 gauge including coaxial cable.

These connectors are available in wide range of shell materials and finishes. Aluminum shells are offered in electroless nickel, olive drab cadmium and bright cadmium. Other finishes such as anodic and zinc cobalt are available upon request to commercial callouts only. In addition, we offer passivated stainless steel shells with standard environment-resisting inserts (commercial callouts only), and for highly corrosive environments, nickel-aluminum-bronze shells with standard environment-resisting inserts (commercial callouts only).

**Universal I/R Tool** – A single, expendable plastic tool is used for both insertion and removal of contacts.

**Scoop-Proof Design** – Recessed pins in elongated shells minimize the possibility for contact damage. In a blind mating application, mating shells cannot “scoop” the pins, and cause a shorting or bending of contacts.

**Closed-Entry Socket Insert** – Hard dielectric socket face has lead-in chamfers for positive alignment of pins (even partially bent within pre-established limits) with sockets.

**Interfacial Pin Insert Seal** – Raised moisture barriers around each pin, which mate into lead-in chamfers of hard face socket insert, provide individual contact sealing. Interfacial seal is never touched by service tools.

**Elastomer Wire Sealing Grommet** – Sealing over a wide range of wire diameters is assured by a triple wire seal in each cavity at the rear of the connector.

**Superior Contact Stability** – Rear release crimp contact system features a stamped beryllium-copper retaining clip captivated by molded-in shoulders of each contact cavity in the insulator. A rear-inserted M81969 plastic tool expands the tines beyond the shoulder, releasing the contact.

**Shell Polarization** – Alternate key/keyway positions prevent cross mating of adjacent connectors having identical insert arrangement.





## Performance Specifications

### Operating Temperature Range

Finish B, BN\* & Z\*: -65°C to +175°C (-85°F to +347°F)

Finish F & S\*: -65°C to +200°C (-85°F to +392°F)

Finish A: -65°C to +150°C (-85°F to +302°F)

### Material and Plating Data (Finish)

B – aluminum shell, olive drab cadmium over nickel base

F – aluminum shell, electroless nickel finish

A – aluminum shell, silver to light iridescent yellow color (bright) cadmium over electroless nickel

BN\* - aluminum shell, black nickel finish (Aero p/n only)(RoHS)

Z\* - Aluminum shell, Black Zinc Nickel Finish (Aero p/n only) (RoHS)

S\* - stainless steel shell, passivated (Aero p/n only) (RoHS)

\*Only commercial version available via AE p/n

### Corrosion Resistance

Finishes A,B, S\* and Z\* withstand 500-hour salt spray. Finish BN\* withstands 400 hour salt spray. Finish F withstands 48-hour salt spray.

### Durability

Minimum of 500 mating cycles

### Environmental Seal

Wired, mated connectors with specified accessories attached, shall meet the altitude-immersion test specified in MIL-DTL-38999.

### Fluid Resistance

Connectors resist specified immersions in MIL-PRF-7808, MIL-PRF-23699, MIL-PRF-5606, M2-V Chevron oil, Coolanol 25, MIL-DTL-83133 (JP-8), MIL-DTL-5624 (JP-4, JP-5), SAE-AMS1424 Type I, and other solvents and cleaning agents.

### Shell-to-Shell Conductivity

- Finish F & BN\* = 1.0 millivolt maximum potential drop
- Finishes A, B & Z\* = 2.5 millivolts maximum potential drop

### Voltage Rating

Service Rating	Suggested Operating Voltage		Test Voltage	Test Voltage	Test Voltage	Test Voltage
	(Sea Level)		Sea Level	50,000 Ft.	70,000 Ft.	100,000 Ft.
	AC (RMS)	DC	V RMS	V RMS	V RMS	V RMS
M	400	550	1300	550	350	200
N	300	450	1000	400	260	200
I	600	850	1800	600	400	200
II	900	1250	2300	800	500	200

**Note:** The establishment of electrical safety factors is left entirely to the designer, as he is in the best position to know

- Finish S\* = 10.0 millivolts maximum potential drop

### Shielding Effectiveness

RFI and EMI attenuation at the specified frequencies meet the requirements of MIL-DTL-38999.

- RFI shielding effectiveness of mated connectors with RFI backshells is measured in a triaxial radio frequency leakage fixture.
- EMI shielding effectiveness is measured at the interface of mated connectors and tested by the mode-stirred technique specified in method 3008 of MIL-STD-1344.

### Shock and Vibration Requirements

Wired, mated connectors shall not be damaged, nor shall there be a current interruption longer than one microsecond when subjected to the following:

#### Standard Shock

Mated connectors withstand a pulse of approximate half sine wave of 300 G ± 15 percent magnitude with duration of 3 ± 1 milliseconds applied in three axes per MIL-STD-1344, method 2004.

#### High Impact Shock

When mounted as specified in MIL-S-901, grade A, a drop of a 400 lb. Hammer from 1 foot, 3 feet and 5 feet applied to connector in three axes, totaling nine impacts.

#### Vibration

Mated connectors, with proper accessories, withstand the following vibration levels:

- Sine Vibration per MIL-STD-202, method 204, test condition G.
- Random Vibration per MIL-STD-1344, method 2005, test condition V and test condition VI, Letter "J" at ambient temperature.

exactly what peak voltages, switching currents, transients, etc., can be expected in a particular circuit.



**MIL-DTL-38999**  
**Part Number Development**  
**Series I**



**Military and Aero-Electric Part Number Development**

38999 S I

Mil. Prefix	MS	27467	T	13	B	35	P	A	
Aero Prefix	AE	167	T	13	B	35	P	A	-340
<b>Shell Type</b>									
27466 = Front, wall mount receptacle = 166 (Aero p/n)									
27467 = RFI grounding plug = 167 (Aero p/n)									
27468 = Jam nut receptacle = 168 (Aero p/n)									
27496 = Front, box mount receptacle = 196 (Aero p/n)									
27505 = Rear, box mount receptacle = 105 (Aero p/n)									
27656 = Rear, wall mount receptacle = 156 (Aero p/n)									
<b>Class</b>									
T = With acc. thread (MS27466, MS27467, MS27468 & MS27656)									
E = Same as T in line above but is not approved for new design (E-nut is not included)									
E = No acc. thread, box mount (MS27496 & MS27505)									
<b>Shell Size</b>									
9, 11, 13, 15, 17, 19, 21, 23 or 25									
<b>Finish (Material &amp; Plating)</b>									
A = Aluminum shell, silver to light iridescent yellow color (bright) cadmium over nickel base									
B = Aluminum shell, olive drab cadmium over electroless nickel base									
F = Aluminum shell, electroless nickel finish									
S = Stainless steel shell, passivated (Aero p/n only)									
BN = Aluminum shell, Black Nickel Finish (Aero p/n only)(RoHS) (n/a for AE167)									
Z = Aluminum shell, Black Zinc Nickel Finish (Aero p/n only)(RoHS) (n/a for AE167)									
<b>Insert Arrangement</b>									
See page 19 thru 21									
<b>Contact Style</b>									
P = Pin									
S = Socket									
A = Pin connector less pins (with intent to use non-standard pin contacts)									
B = Socket connector less sockets (with intent to use non-standard socket contacts)									
<b>Polarization (Keying)</b>									
N = Normal (Omitted in part number)									
A, B, C, or D (B & C keyways are not available in shell size 9)									
<b>Modification</b> (applies to Aero part numbers only)									
01 = Less contacts (is not marked on the part)									
340 = Connector kitted with M85049/27-XXX E-nut									
341 = Connector kitted with M85049/49-2-XXX straight clamp									

**Note 1:** Each connector is furnished with contacts unless ordered less contacts (L/C) as follows: One spare contact for inserts requiring 1 through 26 of each contact and two spares for inserts with more than 26 contacts and a minimum of one sealing plug up to 10% of the number of contacts. Spare Coax and Twinax contacts are not supplied. One insertion/removal tool for each contact size is also included.

**Note 2:** Proper part number marking has no “0” in front of single digit shell size (9) and no “0” in front of single digit layout. Example of each: J MS27466T9B35S and J MS27466T11B5S. In both, “N” for normal is omitted. In addition, J or JAN must now be marked in front of the MS part number.

**Bayonet Coupling, Crimp Removable, Rear Release, Scoop-Proof**

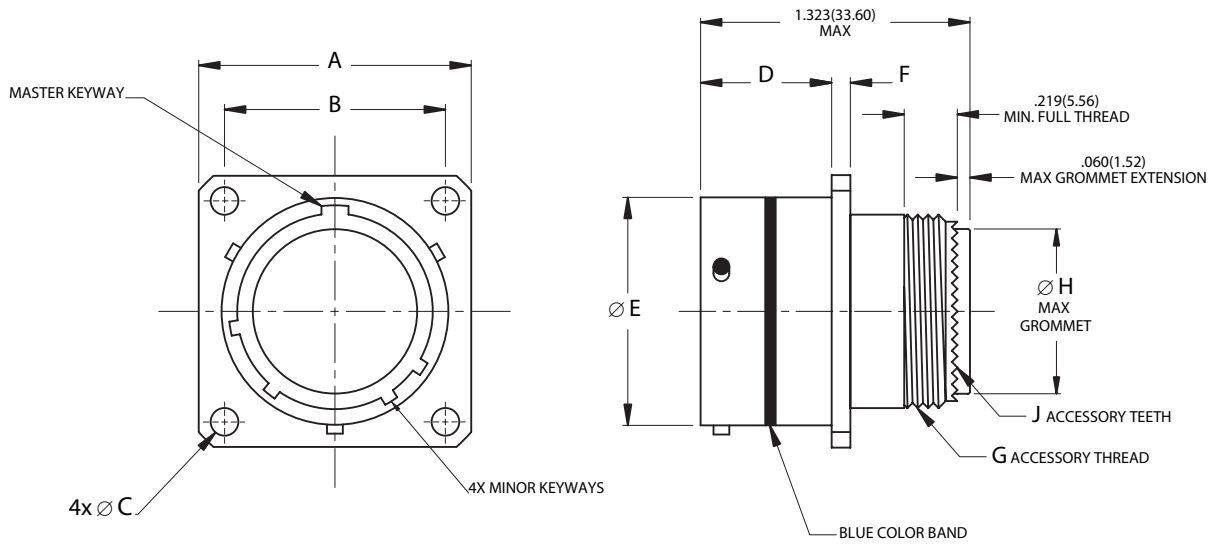

38999 S I

Page 5	Completed Part Number
Page 15	Contacts, Sealing Plugs and Tools
Pages 19–21	Insert Arrangements
Page 4	Performance Specifications
Pages 16-18	Insert Availability and Contact Information
Page 13	Polarization

Shell Size	A		B		Ø C		D		Ø E		F		G	Ø H		J
	±.020	±.51	(TP)		+0.10	+0.25	+0.00	+0.00	+0.01	+0.03	+0.15	+0.38	Accessory Thread	Maximum		No. of Teeth
	inch	mm	inch	mm	inch	mm	inch	mm	inch	mm	inch	mm		inch	mm	
9	.938	23.83	.719	18.26	.128	3.25	.632	16.05	.572	14.53	.085	2.16	7/16-28	.299	7.59	12
11	1.031	26.19	.812	20.62	.128	3.25	.632	16.05	.700	17.78	.085	2.16	9/16-24	.427	10.85	16
13	1.125	28.58	.906	23.01	.128	3.25	.632	16.05	.850	21.59	.085	2.16	11/16-24	.541	13.74	20
15	1.219	30.96	.969	24.61	.128	3.25	.632	16.05	.975	24.77	.085	2.16	13/16-20	.666	16.92	24
17	1.312	33.32	1.062	26.97	.128	3.25	.632	16.05	1.100	27.94	.085	2.16	15/16-20	.791	20.09	28
19	1.438	36.53	1.156	29.36	.128	3.25	.632	16.05	1.207	30.66	.085	2.16	1-1/16-18	.897	22.78	32
21	1.562	39.67	1.250	31.75	.128	3.25	.602	15.29	1.332	33.83	.115	2.92	1-3/16-18	1.022	25.96	36
23	1.688	42.88	1.375	34.93	.147	3.73	.602	15.29	1.457	37.01	.115	2.92	1-5/16-18	1.147	29.13	40
25	1.812	46.02	1.500	38.10	.147	3.73	.602	15.29	1.582	40.18	.115	2.92	1-7/16-18	1.272	32.31	44

**MS27656**  
**Rear, Wall Mounting Receptacle**  
**AE156**



**Bayonet Coupling, Crimp Removable, Rear Release, Scoop-Proof**

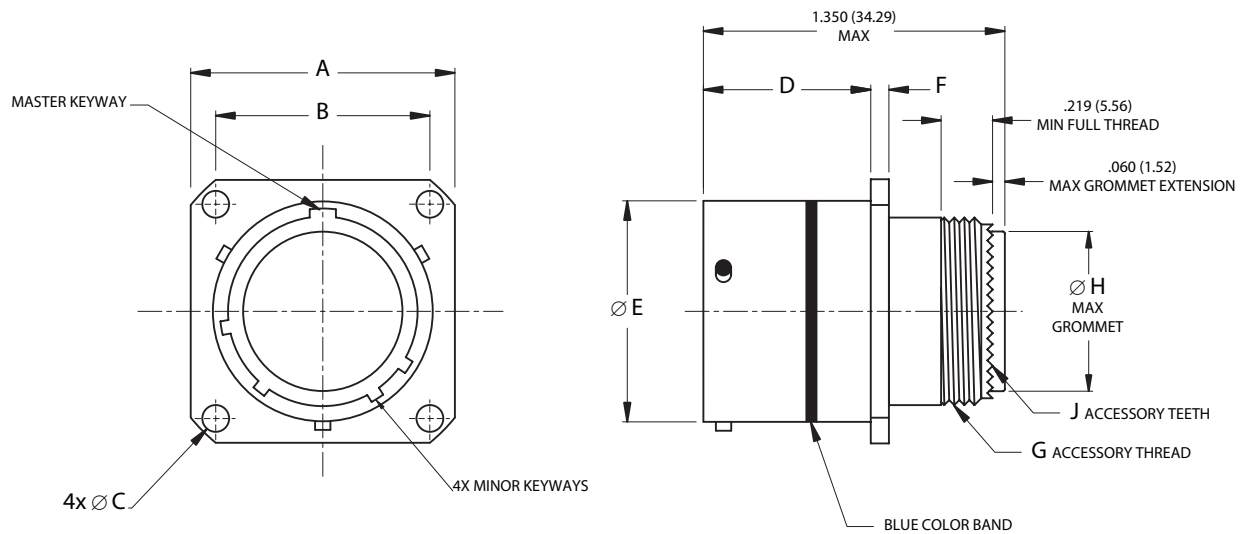

38999 S I

Page 5	Completed Part Number
Page 15	Contacts, Sealing Plugs and Tools
Pages 19–21	Insert Arrangements
Page 4	Performance Specifications
Pages 16-18	Insert Availability and Contact Information
Page 13	Polarization

**Note:** See page 14 for panel thickness.

Shell Size	A		B		Ø C		D		Ø E		F		G	Ø H		J
	±.020	±.51	(TP)		+0.010	+0.25	+0.000	+0.00	+0.001	+0.03	+0.015	+0.38	Accessory Thread	Maximum		No. of Teeth
	inch	mm	inch	mm	inch	mm	inch	mm	inch	mm	inch	mm		inch	mm	
9	.938	23.83	.719	18.26	.128	3.25	.820	20.83	.572	14.53	.085	2.16	7/16-28	.299	7.59	12
11	1.031	26.19	.812	20.62	.128	3.25	.820	20.83	.700	17.78	.085	2.16	9/16-24	.427	10.85	16
13	1.125	28.58	.906	23.01	.128	3.25	.820	20.83	.850	21.59	.085	2.16	11/16-24	.541	13.74	20
15	1.219	30.96	.969	24.61	.128	3.25	.820	20.83	.975	24.77	.085	2.16	13/16-20	.666	16.92	24
17	1.312	33.32	1.062	26.97	.128	3.25	.820	20.83	1.100	27.94	.085	2.16	15/16-20	.791	20.09	28
19	1.438	36.53	1.156	29.36	.128	3.25	.820	20.83	1.207	30.66	.085	2.16	1-1/16-18	.897	22.78	32
21	1.562	39.67	1.250	31.75	.128	3.25	.790	20.07	1.332	33.83	.115	2.92	1-3/16-18	1.022	25.96	36
23	1.688	42.88	1.375	34.93	.147	3.73	.790	20.07	1.457	37.01	.115	2.92	1-5/16-18	1.147	29.13	40
25	1.812	46.02	1.500	38.10	.147	3.73	.790	20.07	1.582	40.18	.115	2.92	1-7/16-18	1.272	32.31	44



**Bayonet Coupling, Crimp Removable, Rear Release, Scoop-Proof**

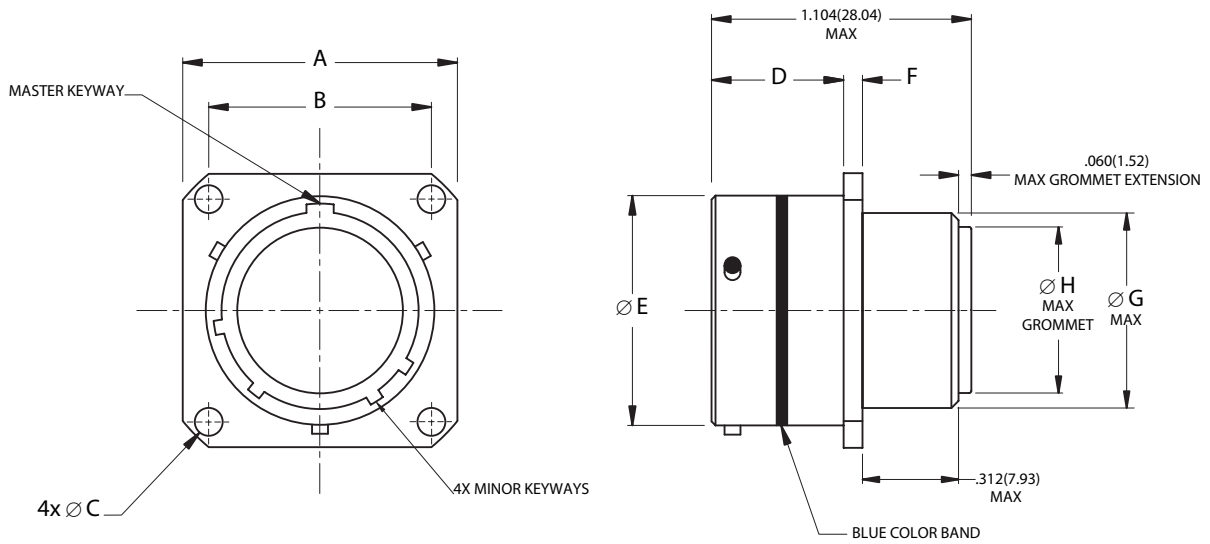

38999 S I

Page 5	Completed Part Number
Page 15	Contacts, Sealing Plugs and Tools
Pages 19–21	Insert Arrangements
Page 4	Performance Specifications
Pages 16-18	Insert Availability and Contact Information
Page 13	Polarization

Shell Size	A		B		Ø C		D		Ø E		F		Ø G		Ø H	
	±.020	±.51	(TP)		+0.10	+0.25	+0.00	+0.00	+0.01	+0.03	+0.15	+0.38	Maximum		Maximum	
	inch	mm	inch	mm	inch	mm	inch	mm	inch	mm	inch	mm	inch	mm	inch	mm
9	.938	23.83	.719	18.26	.128	3.25	.632	16.05	.572	14.53	.085	2.16	.469	11.91	.299	7.59
11	1.031	26.19	.812	20.62	.128	3.25	.632	16.05	.700	17.78	.085	2.16	.594	15.09	.427	10.85
13	1.125	28.58	.906	23.01	.128	3.25	.632	16.05	.850	21.59	.085	2.16	.719	18.26	.541	13.74
15	1.219	30.96	.969	24.61	.128	3.25	.632	16.05	.975	24.77	.085	2.16	.844	21.44	.666	16.92
17	1.312	33.32	1.062	26.97	.128	3.25	.632	16.05	1.100	27.94	.085	2.16	.969	24.61	.791	20.09
19	1.438	36.53	1.156	29.36	.128	3.25	.632	16.05	1.207	30.66	.085	2.16	1.078	27.38	.897	22.78
21	1.562	39.67	1.250	31.75	.128	3.25	.602	15.29	1.332	33.83	.115	2.92	1.203	30.56	1.022	25.96
23	1.688	42.88	1.375	34.93	.147	3.73	.602	15.29	1.457	37.01	.115	2.92	1.328	33.73	1.147	29.13
25	1.812	46.02	1.500	38.10	.147	3.73	.602	15.29	1.582	40.18	.115	2.92	1.453	36.91	1.272	32.31

**MS27505**

**Rear, Box Mounting Receptacle**

**AE105**



**Bayonet Coupling, Crimp Removable, Rear Release, Scoop-Proof**

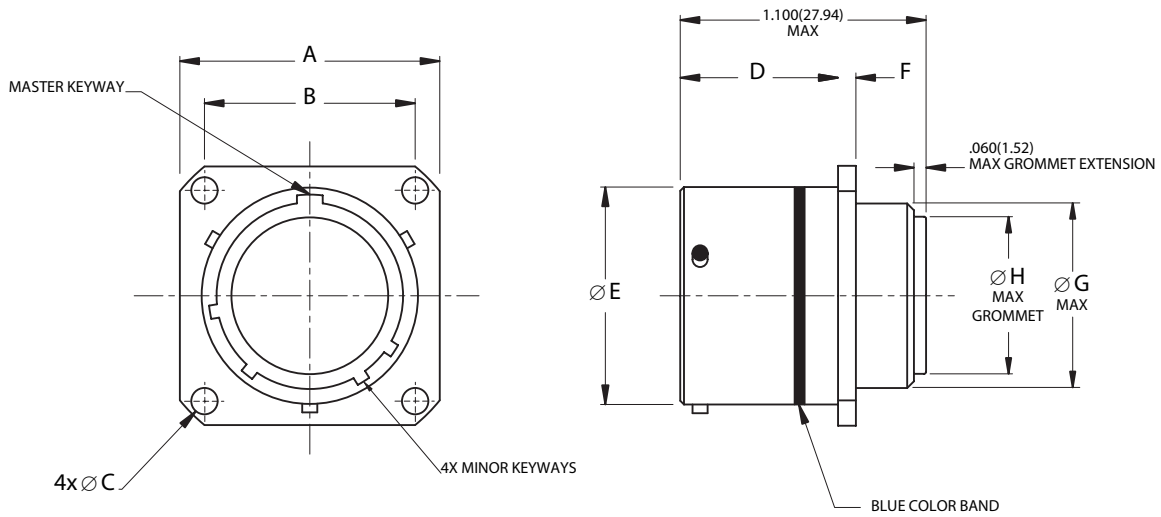

38999 S I

Page 5	Completed Part Number
Page 15	Contacts, Sealing Plugs and Tools
Pages 19–21	Insert Arrangements
Page 4	Performance Specifications
Pages 16-18	Insert Availability and Contact Information
Page 13	Polarization

**Note:** See page 14 for panel thickness.

Shell Size	A		B		Ø C		D		Ø E		F		Ø G		Ø H	
	±.020	±.51	(TP)		+0.10	+0.25	+0.00	+0.00	+0.001	+0.03	+0.015	+0.38	Maximum		Maximum	
	inch	mm	inch	mm	inch	mm	inch	mm	inch	mm	inch	mm	inch	mm	inch	mm
9	.938	23.83	.719	18.26	.128	3.25	.820	20.83	.572	14.53	.085	2.16	.547	13.89	.299	7.59
11	1.031	26.19	.812	20.62	.128	3.25	.820	20.83	.700	17.78	.085	2.16	.656	16.66	.427	10.85
13	1.125	28.58	.906	23.01	.128	3.25	.820	20.83	.850	21.59	.085	2.16	.828	21.03	.541	13.74
15	1.219	30.96	.969	24.61	.128	3.25	.820	20.83	.975	24.77	.085	2.16	.953	24.21	.666	16.92
17	1.312	33.32	1.062	26.97	.128	3.25	.820	20.83	1.100	27.94	.085	2.16	1.078	27.38	.791	20.09
19	1.438	36.53	1.156	29.36	.128	3.25	.820	20.83	1.207	30.66	.085	2.16	1.203	30.56	.897	22.78
21	1.562	39.67	1.250	31.75	.128	3.25	.790	20.07	1.332	33.83	.115	2.92	1.328	33.73	1.022	25.96
23	1.688	42.88	1.375	34.93	.147	3.73	.790	20.07	1.457	37.01	.115	2.92	1.453	36.91	1.147	29.13
25	1.812	46.02	1.500	38.10	.147	3.73	.790	20.07	1.582	40.18	.115	2.92	1.578	40.08	1.272	32.31

**Bayonet Coupling, Crimp Removable, Rear Release, Scoop-Proof**

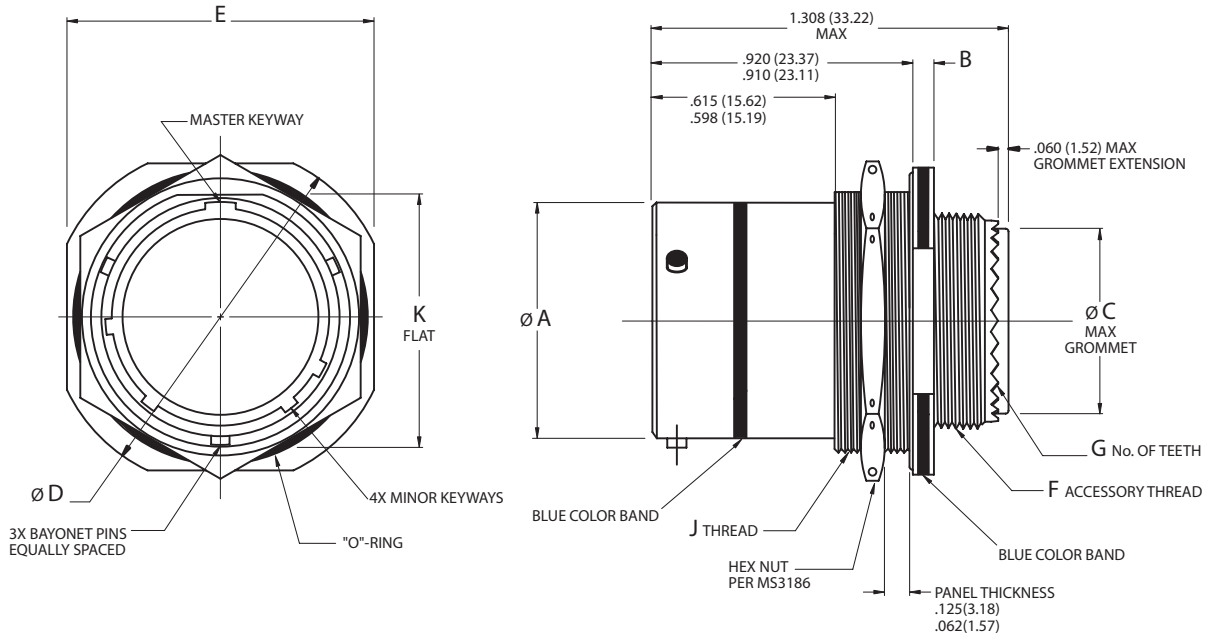

38999 S I

Page 5	Completed Part Number
Page 15	Contacts, Sealing Plugs and Tools
Pages 19–21	Insert Arrangements
Page 4	Performance Specifications
Pages 16-18	Insert Availability and Contact Information
Page 13	Polarization

Shell Size	Ø A		B		Ø C		Ø D		E		F	G	J	K	
	+0.01	+0.03	+0.11	+0.28	Maximum	±0.16	±0.41	±0.16	±0.41	Accessory Thread	No. of Teeth	Jam Nut Thread Class 2A	±0.005	±0.13	
	-0.005	-0.13	-0.10	-0.25		inch	mm	inch	mm				inch	mm	inch
9	.572	14.53	.109	2.77	.299	7.59	1.188	30.18	1.062	26.97	7/16-28	12	11/16-24UNEF	.650	16.51
11	.700	17.78	.109	2.77	.427	10.85	1.375	34.93	1.250	31.75	9/16-24	16	13/16-20UNEF	.750	19.05
13	.850	21.59	.109	2.77	.541	13.74	1.500	38.10	1.375	34.93	11/16-24	20	1-20UNEF	.937	23.80
15	.975	24.77	.109	2.77	.666	16.92	1.625	41.28	1.500	38.10	13/16-20	24	1-1/8-18UNEF	1.061	26.95
17	1.100	27.94	.109	2.77	.791	20.09	1.750	44.45	1.625	41.28	15/16-20	28	1-1/4-18UNEF	1.186	30.12
19	1.207	30.66	.140	3.56	.897	22.78	1.938	49.23	1.812	46.02	1-1/16-18	32	1-3/8-18UNEF	1.311	33.30
21	1.332	33.83	.140	3.56	1.022	25.96	2.062	52.37	1.938	49.23	1-3/16-18	36	1-1/2-18UNEF	1.436	36.47
23	1.457	37.01	.140	3.56	1.147	29.13	2.188	55.58	2.062	52.37	1-5/16-18	40	1-5/8-18UNEF	1.561	39.65
25	1.582	40.18	.140	3.56	1.272	32.31	2.312	58.72	2.188	55.58	1-7/16-18	44	1-3/4-18UNS	1.686	42.82

**MS27467**  
**RFI Grounding Plug**  
**AE167**



**Bayonet Coupling, Crimp Removable, Rear Release, Scoop-Proof**

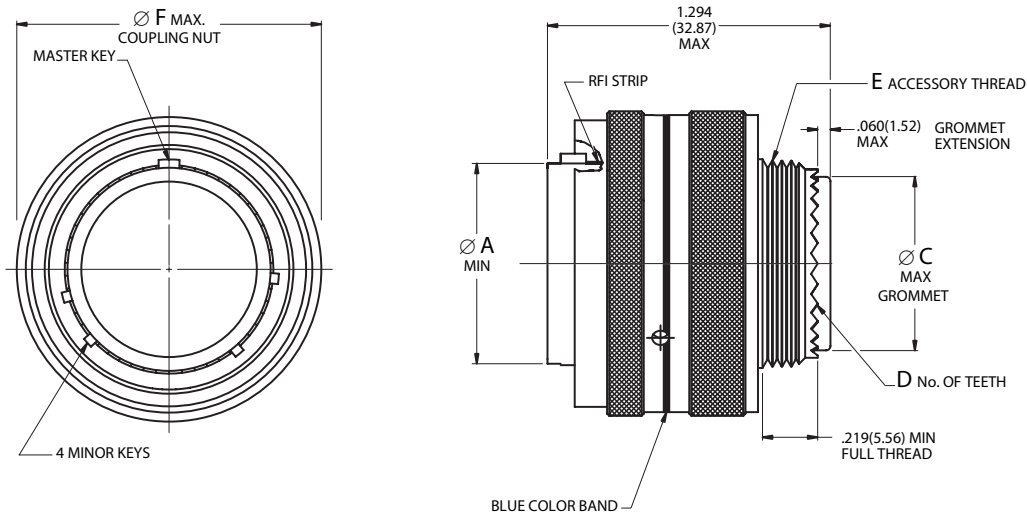

38999 S I

Page 5	Completed Part Number
Page 15	Contacts, Sealing Plugs and Tools
Pages 19–21	Insert Arrangements
Page 4	Performance Specifications
Pages 16-18	Insert Availability and Contact Information
Page 13	Polarization

Shell Size	Ø A		Ø C		D	E	Ø F	
	Minimum		Maximum		No. of Teeth	Accessory Thread Class 2A	Maximum	
	inch	mm	inch	mm			inch	mm
9	.417	10.59	.299	7.59	12	7/16-28UNEF	.859	21.82
11	.545	13.84	.427	10.85	16	9/16-24UNEF	.984	24.99
13	.657	16.69	.541	13.74	20	11/16-24UNEF	1.156	29.36
15	.782	19.86	.666	16.92	24	13/16-20UNEF	1.281	32.54
17	.907	23.04	.791	20.09	28	15/16-20UNEF	1.406	35.71
19	1.012	25.70	.897	22.78	32	1-1/16-18UNEF	1.516	38.51
21	1.137	28.88	1.022	25.96	36	1-3/16-18UNEF	1.641	41.68
23	1.262	32.05	1.147	29.13	40	1-5/16-18UNEF	1.766	44.86
25	1.387	35.23	1.272	32.31	44	1-7/16-18UNEF	1.891	48.03

**Dummy Storage Receptacle, Bayonet Coupling**

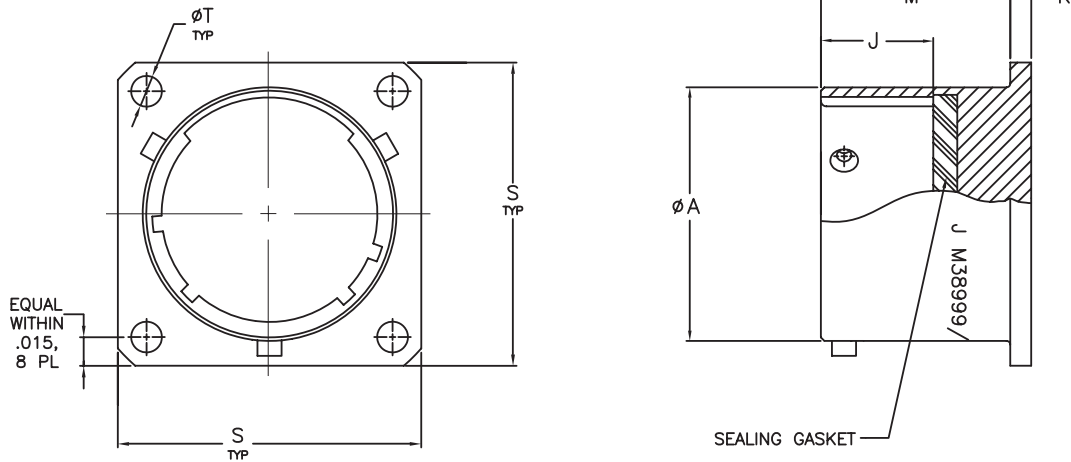

**Part Number Configuration**

<b>MIL. Prefix</b>	<b>M38999</b>	<b>9/</b>	<b>XX</b>	<b>B</b>
<b>Aero Prefix</b>	<b>AE10</b>	<b>9-</b>	<b>XX</b>	<b>B</b>
<b>Shell Type</b>				
9 = receptacle, dummy stowage, bayonet coupling				
<b>Shell Size</b>				
9 THRU 25 (Note: single digit for shell size 9)				
<b>Material Finish</b>				
B = Aluminum, Cadmium Olive Drab				
A = Aluminum, Bright Cadmium over Nickel base (Aero p/n only)				
F = Aluminum shell, Electroless Nickel finish (Aero p/n only)				
S = Stainless steel shell, passivated (Aero p/n only)				
BN = Aluminum, Black Nickel (Aero p/n only)				
BZ = Bronze (Aero p/n only)				
Z = Aluminum shell, Black Zinc Nickel (Aero p/n only)				

SHELL SIZE	$\phi A$ +.001 -.005	K +.015 -.000	M $\pm .010$	$\phi T$ +.010 -.005	S $\pm .020$	J +.010 -.015
9	.572	.085	.727	.128	.938	.567
11	.700	.085	.727	.128	1.031	.567
13	.850	.085	.727	.128	1.125	.567
15	.975	.085	.727	.128	1.219	.567
17	1.100	.085	.727	.128	1.312	.567
19	1.207	.085	.727	.128	1.438	.567
21	1.332	.115	.697	.128	1.562	.567
23	1.457	.115	.697	.147	1.688	.567
25	1.582	.115	.697	.147	1.812	.567



### Keying Positions

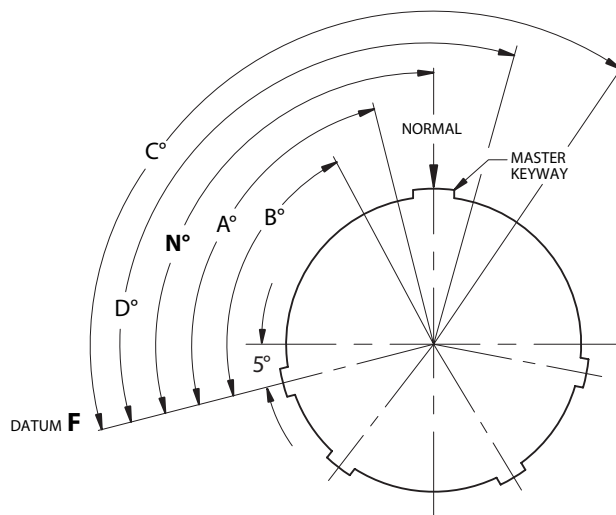

**Notes:**

1. Mating face of receptacle shown (plug is opposite).
2. The master keyway (key) has various positions relative to DATUM **F**; the minor keyways (keys) remain fixed as shown. In the Normal position, the master keyway (key) is at 95° from DATUM **F**.
3. The angles for a given connector are the same whether it contains pin or socket inserts.
4. The insert arrangement does not rotate relative to master keyway (key).

Shell Size	Keying Positions				
	BSC				
	N°	A°	B°	C°	D°
9	95	77	-	-	113
11	95	81	67	123	109
13	95	75	63	127	115
15	95	74	61	129	116
17	95	77	65	125	113
19	95	77	65	125	113
21	95	77	65	125	113
23	95	80	69	121	110
25	95	80	69	121	110

**Panel Cutouts**

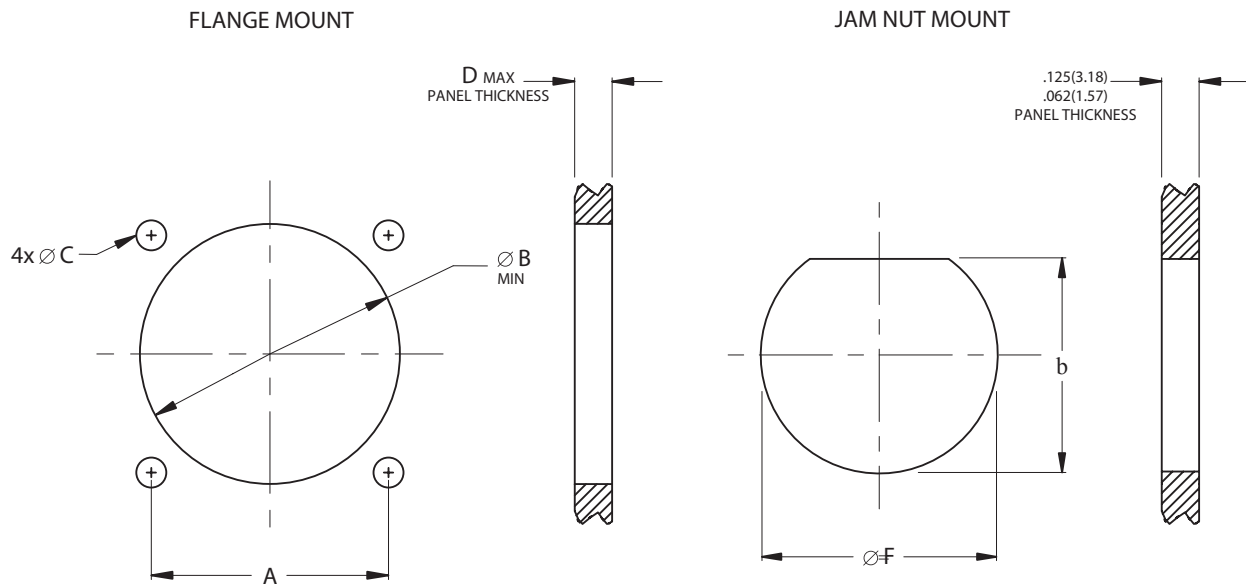

38999 S I

**Note 1:** Flange Mounting Dimensions ( $\varnothing B$  cutout and  $D_{MAX}$ ) listed only for back of panel mounting (MS27505 and MS27656).

**Note 2:**  $D_{MAX}$  includes mounting hardware.

**Flange and Jam Nut Mounting Dimensions**

Shell Size	A		$\varnothing B$		$\varnothing C$		D		E		$\varnothing F$	
	(TP)		Minimum		$\pm .005$	$\pm .13$	Maximum		$+.000^*$ $-.010$	$+.00^*$ $-.25$	$+.010$ $-.000$	$+.25$ $-.00$
	inch	mm	inch	mm	inch	mm	inch	mm	inch	mm	inch	mm
9	.719	18.26	.656	16.66	.128	3.25	.234	5.94	.657*	16.70*	.693	17.60
11	.812	20.62	.796	20.22	.128	3.25	.234	5.94	.771	19.59	.825	20.96
13	.906	23.01	.922	23.42	.128	3.25	.234	5.94	.955	24.26	1.010	25.65
15	.969	24.61	1.047	26.59	.128	3.25	.234	5.94	1.085	27.56	1.135	28.83
17	1.062	26.97	1.219	30.96	.128	3.25	.234	5.94	1.210	30.73	1.260	32.01
19	1.156	29.36	1.297	32.94	.128	3.25	.234	5.94	1.335	33.91	1.385	35.18
21	1.250	31.75	1.422	36.12	.128	3.25	.204	5.18	1.460	37.08	1.510	38.35
23	1.375	34.93	1.547	39.29	.154	3.91	.204	5.18	1.585	40.26	1.635	41.53
25	1.500	38.10	1.672	42.47	.154	3.91	.193	4.90	1.710	43.43	1.760	44.70

\* Tolerance  $\pm .10\text{mm}$  ( $\pm .004''$ )

**MIL-DTL-38999****Contacts, Tools and Seal Plugs****Series I****Contacts, Plastic Insertion/Removal Tools and Seal Plugs**

Contact Size	Application	Pin Contacts	Socket Contacts	Seal Plugs	Insertion/Removal Tools
	Type	Military No.	Military No.	Military No.	Military No.
22D	Power/Signal	M39029/58-360	M39029/56-348	MS27488-22-1	M81969/14-01
22M*	Power/Signal	M39029/58-361	M39029/56-349		—
22*	Power/Signal	M39029/58-362	M39029/56-350		—
20	Power/Signal	M39029/58-363	M39029/56-351	MS27488-20-1	M81969/14-10
16	Power/Signal	M39029/58-364	M39029/56-352	MS27488-16-1	M81969/14-03
12	Power/Signal	M39029/58-365	M39029/56-353	MS27488-12-1	M81969/14-04
12 Coax	Coax	M39029/28-211	M39029/75-416		
12 Coax	Coax	M39029/102-558	M39029/103-559		
8 Coax	Coax	M39029/60-367	M39029/59-366	MS27488-8-1	M81969/14-06
8 Twinax	Twinax	M39029/90-529	M39029/91-530	MS27488-8-1	M81969/14-12

**Crimping and Metal Insertion/Extraction Tools**

Contact Size/ Type	Crimp Tool	Positioner	Positioner	Insertion Tool	Extraction Tool
	Military No.	For Pin Contacts Military No.	For Socket Contacts Military No.	Metal Military No.	Metal Military No.
22D, 22M*	M22520/2-01	M22520/2-09	M22520/2-07	M81969/8-01	M81969/8-02
22*	M22520/2-01	M22520/2-09	M22520/2-07	M81969/8-03	M81969/8-04
20	M22520/1-01	M22520/1-04	M22520/1-04	M81969/8-05	M81969/8-06
	M22520/2-01	M22520/2-10	M22520/2-10		
16	M22520/1-01	M22520/1-04	M22520/1-04	M81969/8-07	M81969/8-08
12	M22520/1-01	M22520/1-04	M22520/1-04	M81969/8-09	M81969/8-10
12 Coax Inner	M22520/2-01	M22520/2-34	M22520/2-34		
12 Coax Outer	M22520/31-01	M22520/31-02	M22520/31-02		
8 Coax Inner	M22520/2-01	M22520/2-31	M22520/2-31	M81969/8-13**	M81969/8-14
8 Coax Outer	M22520/5-01	M22520/5-05 Die Closure B	M22520/5-05 Die Closure B		
8 Twinax Center	M22520/2-01	M22520/2-37	M22520/2-37	—	—
8 Twinax Outer & Intermediate	M22520/5-01	M22520/5-200	M22520/5-200		

**Contact and Wire Data**

Contact Size	Test Current	Voltage	Crimp Well Data			Wire Range		Finished Wire Ø Range			
	DC Test Amps	Max. Drop Millivolts	Well Dia. inch	Minimum Well Dept inch mm		AWG	mm <sup>2</sup>	Minimum		Maximum	
22D	5.0	73	.0345 ±.0010	.141	3.58	28-22	.08-.33	.030	.76	.054	1.37
22M*	3.0	45	.028 ±.001	.141	3.58	28-24	.08-.20	.030	.76	.050	1.27
22*	5.0	73	.0365 ±.0010	.141	3.58	26-22	.13-.33	.034	.86	.060	1.52
20	7.5	55	.047 ±.001	.209	5.31	24-20	.20-.52	.040	1.02	.083	2.11
16	13.0	49	.067 ±.001	.209	5.31	20-16	.52-1.31	.065	1.65	.109	2.77
12	23.0	42	.100 ±.002	.209	5.31	14-12	2.08-3.31	.097	2.46	.142	3.61

\* Inactive for new design

\*\* Insertion tool is not required.

**Note 1:** Test Current and Maximum Voltage Drop when tested with silver-plated wire at 25°C.**Note 2:** Size 12 coax contacts purchased in bulk.**Note 3:** Size 8 coax contacts are used with M17/095-RG180 cable, while size 8 Twinax contacts are used with M17/176-00002 cable.**Note 4:** Size 8 Power contacts available with various crimp wells – 5265-244-08xx and 5065-246-08xx – please consult factory for sales drawing that includes various tooling needed

38999 S I



MIL-DTL-38999

## Contact Installation Instructions Series I

38999 S I

# Contact Installation Instructions

### Crimping Contacts

1. Select the appropriate crimp tool and ensure that the proper crimp head positioner is used.
2. Cycle the tool to be sure the indentors are open.
3. Determine the correct selector setting for the wire size from the data plate on the positioner (turret head assembly) and set the selector knob on the crimp tool to match.
4. Place the contact, mating end first, into the tool.
5. Insert the stripped wire into the hollow end of the contact. Be sure the wire is inserted as far as it will go.
6. Close the tool completely to crimp. Unless the tool is closed completely, the tool will not release the contact.
7. Remove the crimped contact from the tool. Check the inspection hole to verify that the wire is fully inserted.

### Insertion of Contacts

1. Before inserting the contacts, unscrew the accessories (clamps, backshells or adapters) from rear of plug or receptacle. Slide the hardware over the wire bundle in the proper order for reassembly after all the contacts are inserted.
2. To assist insertion of contacts, lubricate insulator (grommet) cavities with isopropyl alcohol. Alcohol will evaporate and will not leave a conductive film. **Caution: Never use any lubricant other than isopropyl alcohol.**

3. Place the correct insertion tool on the contact so that the wire runs along the groove in the tool. (Tool tip will butt against the shoulder.) Hold the plug or receptacle body firmly.
4. Beginning with a center cavity, insert the contact into the insulator with a slow, even pressure until the contact snaps into position. Make sure the contact and tool are held perpendicular to the face of the insert during the contact installation or the grommet could be damaged.
  - 4.1 If contacts are not inserted all the way prior to removing insertion tool, do not try to reinsert the insertion tool. Instead, remove the contact and try again; otherwise reinserting the insertion tool may damage the inside of the contact cavity.
5. Remove tool and check the face of the connector for proper contact installation. Proper installation may also be checked by pulling back lightly on the wire to make sure the contact is properly seated.

### Completion

After all the cavities have been filled, slide the hardware back into position on the connector and tighten.

### Extraction of Contacts (Rework)

1. Slide the hardware back over the wire bundle.
2. Select the appropriate tool. Place the wire into the extraction tool of the pin or socket.
3. Slowly slide the extraction tool down wire into the contact cavities until the tool tip bottoms against the contact shoulder, expanding the clip retaining tines. Hold the wire firmly in the tool and pull the wired contact and tool straight out of the rear of the insulator.

Size	Pin Contact	Socket Contact	Basic Crimp Tool	Pin Positioner	Socket Positioner	Insertion/Removal Tool
22D	M39029/58-360	M39029/56-348	M22520/2-01	M22520/2-09	M22520/2-07	M81969/14-01
22M	M39029/58-361	M39029/56-349	M22520/2-01	M22520/2-09	M22520/2-07	M81969/14-01
22	M39029/58-362	M39029/56-350	M22520/2-01	M22520/2-09	M22520/2-07	M81969/14-01
20	M39029/58-363	M39029/56-351	M22520/1-01	M22520/1-04 Red	M22520/1-04 Red	M81969/14-10
			M22520/2-01	M22520/2-10	M22520/2-10	
20	M39029/58-364	M39029/56-352	M22520/1-01	M22520/1-04 Blue	M22520/1-04 Blue	M81969/14-03
12	M39029/58-365	M39029/56-353	M22520/1-01	M22520/1-04 Yellow	M22520/1-04 Yellow	M81969/14-04

For coax and twinax contacts refer to instructions that are supplied with contacts.

Note 4: Size 8 Power contacts available with various crimp wells – 5265-244-08xx and 5065-246-08xx – please consult factory for sales drawing that includes various tooling needed

**MIL-DTL-38999 Series I**  
**Insert Availability and Contact Information**  
**per MIL-STD-1560**



**Insert Availability and Contact Information**

Insert Arrangement	Aero-Electric		Service	Total	Quantity of Contacts								
	Status			No. of	(by Size)								
	Series I	QPL'd	Tooled	Rating	Contacts	22D	22M	22	20	16	12	10	8
9-6*	Yes	Yes	M	6		6							
9-35	Yes	Yes	M	6	6								
9-98	Yes	Yes	I	3				3					
11-2	Yes	Yes	I	2					2				
11-4	Yes	Yes	I	4				4					
11-5	Yes	Yes	I	5				5					
11-13*	Yes	Yes	M	13		13							
11-35	Yes	Yes	M	13	13								
11-98	Yes	Yes	I	6				6					
11-99	Yes	Yes	I	7				7					
13-4	Yes	Yes	I	4					4				
13-8	Yes	Yes	I	8				8					
13-22*	Yes	Yes	M	22		22							
13-35	Yes	Yes	M	22	22								
13-98	Yes	Yes	I	10				10					
15-5	Yes	Yes	II	5					5				
15-15	Yes	Yes	I	15				14	1				
15-18	Yes	Yes	I	18				18					
15-19	Yes	Yes	I	19				19					
15-35	Yes	Yes	M	37	37								
15-37*	Yes	Yes	M	37		37							
15-97	Yes	Yes	I	12				8	4				
17-6	Yes	Yes	I	6						6			
17-8	Yes	Yes	II	8					8				
17-26	Yes	Yes	I	26				26					
17-35	Yes	Yes	M	55	55								
17-55*	Yes	Yes	M	55		55							
17-99	Yes	Yes	I	23				21	2				
19-11	Yes	Yes	II	11					11				
19-28	Yes	Yes	I	28				26	2				
19-30	Yes	Yes	I	30				29	1				
19-32	Yes	Yes	I	32				32					
19-35	Yes	Yes	M	66	66								
19-66*	Yes	Yes	M	66		66							

See next page for Shell Sizes 21 thru 25 layouts.

\* Not approved for new design. Toolled and qualified but their separate pictorials are not shown on pages 19 thru 21, as they are the same as corresponding (-35) layouts that take the same quantity of 22D contacts, but are supplied with 22M contacts instead.

38999 S I



**MIL-DTL-38999 Series I**  
**Insert Availability and Contact Information**  
**per MIL-STD-1560**

**Insert Availability and Contact Information (continued)**

Insert Arrangement	Aero-Electric		Service	Total	Quantity of Contacts							
	Status			No. of	(by Size)							
Series I	QPL'd	Tooled	Rating	Contacts	22D	22M	22	20	16	12	10	8
21-1*	Yes	Yes	M	79		79						
21-11	Yes	Yes	I	11						11		
21-16	Yes	Yes	II	16					16			
21-35	Yes	Yes	M	79	79							
21-39	Yes	Yes	I	39				37	2			
21-41	Yes	Yes	I	41				41				
21-48**	N/A	Yes	I	4								4 (Power)
21-75	Yes	Yes	Twinax	4								4 (Twinax)
23-1*	Yes	Yes	M	100		100						
23-2***	Yes	Yes	M	85			85					
23-21	Yes	Yes	II	21					21			
23-32	Yes	Yes	I	32				32				
23-35	Yes	Yes	M	100	100							
23-53	Yes	Yes	I	53				53				
23-55	Yes	Yes	I	55				55				
25-1*	Yes	Yes	M	128		128						
25-4	Yes	Yes	I	56				48	8			
25-19	Yes	Yes	I	19						19		
25-24	Yes	Yes	I	24					12	12		
25-29	Yes	Yes	I	29					29			
25-35	Yes	Yes	M	128	128							
25-43	Yes	Yes	I	43				23	20			
25-46	Yes	Yes	I, Coax	46				40	4			2 (Coax)
25-61	Yes	Yes	I	61				61				

38999 S I

\* Not approved for new design. Tooled and qualified but their separate pictorials are not shown on pages 19 thru 21, as they are same as corresponding (-35) layouts that take the same quantity of 22D contacts, but are supplied with 22M contacts instead.

\*\* 21-48 layout is not to MIL-STD-1560. It is tooled and intended for commercial use only.

\*\*\* Not approved for new design. Pictorial is shown on page 20.

**MIL-STD-1560**  
**Insert Arrangements (Pin Front View)**  
**for MIL-DTL-38999 Series I Connectors**



**Insert Arrangements Views**

38999 S I



9-35  
6 # 22D ,M



9-98  
3 # 20 ,I

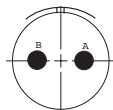

11-2  
2 # 16 ,I

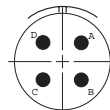

11-4  
4 # 20 ,I

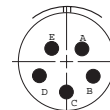

11-5  
5 # 20 ,I

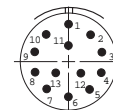

11-35  
13 # 22D ,M

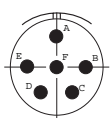

11-98  
6 # 20 ,I

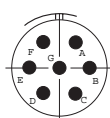

11-99  
7 # 20 ,I

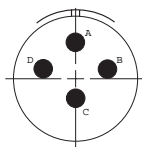

13-4  
4 # 16 ,I

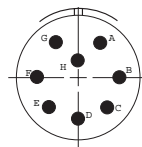

13-8  
8 # 20 ,I

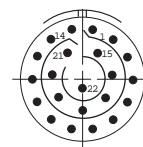

13-35  
22 # 22D ,M

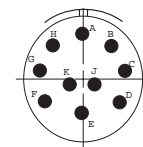

13-98  
10 # 20 ,I

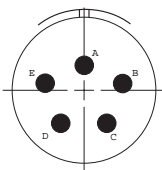

15-5  
5 # 16 ,II

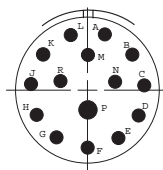

15-15  
1 # 16 ,14 # 20 ,I

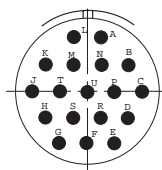

15-18  
18 # 20 ,I

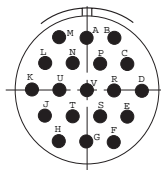

15-19  
19 # 20 ,I

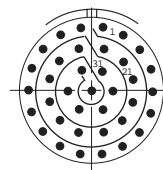

15-35  
37 # 22D ,M

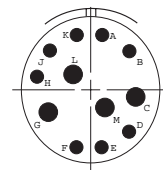

15-97  
4 # 16 ,8 # 20 ,I

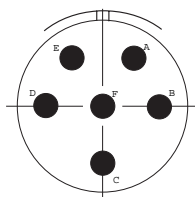

17-6  
6 # 12 ,I

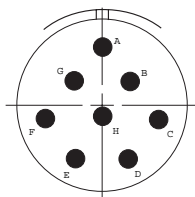

17-8  
8 # 16 ,II

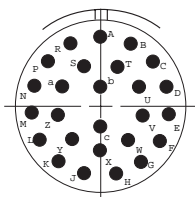

17-26  
26 # 20 ,I

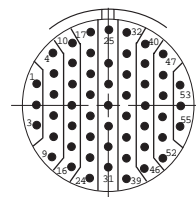

17-35  
55 # 22D ,M

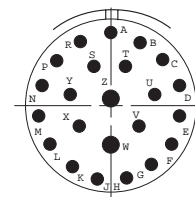

17-99  
2 # 16 ,21 # 20 ,I

Insert Arrangements Views

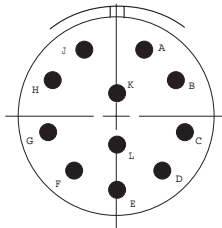

19-11  
11 # 16, II

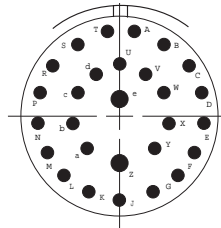

19-28  
2 # 16, 26 # 20, I

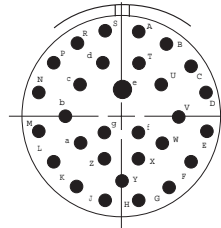

19-30  
1 # 16, 29 # 20, I

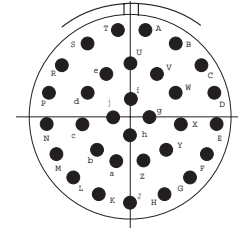

19-32  
32 # 20, I

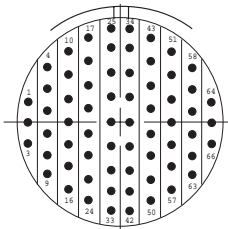

19-35  
66 # 22D, M

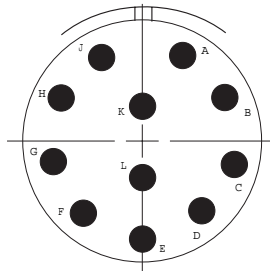

21-11  
11 # 12, I

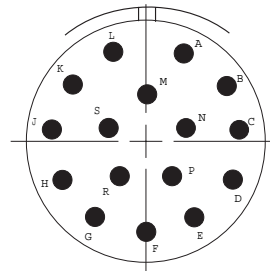

21-16  
16 # 16, II

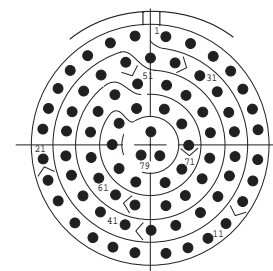

21-35  
79 # 22D, M

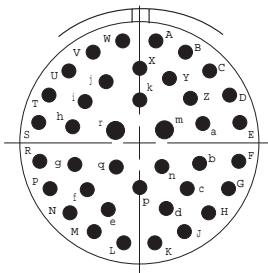

21-39  
2 # 16, 37 # 20, I

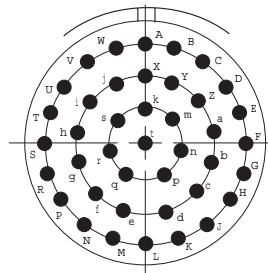

21-41  
41 # 20, I

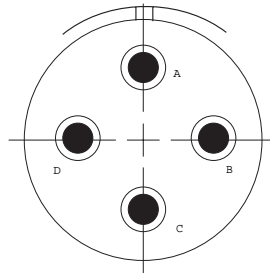

21-48\*\*  
4 # 8 Power, I

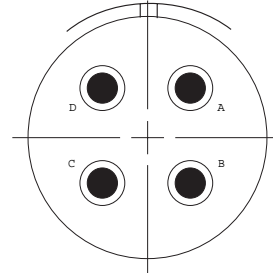

21-75  
4 # 8 Twinax, Twinax

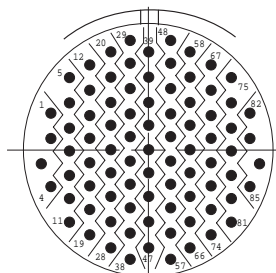

23-2\*  
85 # 22, M

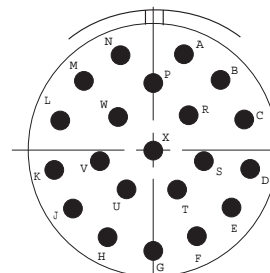

23-21  
21 # 16, II

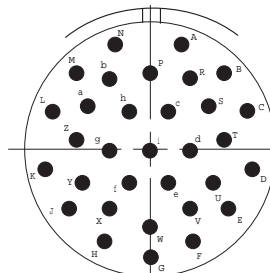

23-32  
32 # 20, I

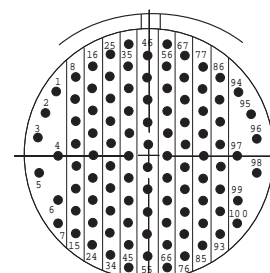

23-35  
100 # 22D, M

\* Inactive for new design.  
\*\* Not MIL-STD-1560 layout (not QPL'd).



38999 S I

Insert Arrangements Views

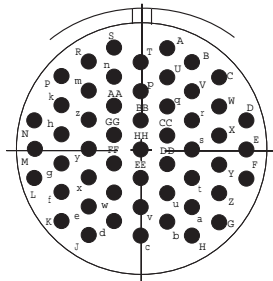

23-53  
55 # 20, I

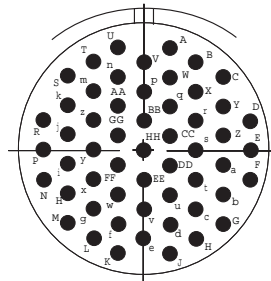

23-55  
55 # 20, I

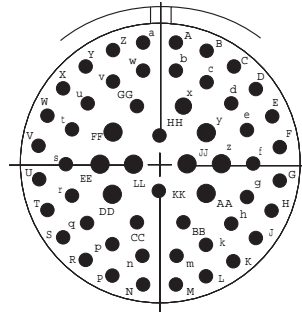

25-4  
8 # 16, 48 # 20, I

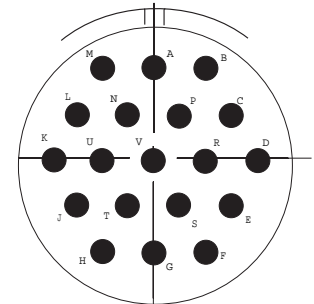

25-19  
19 # 12, I

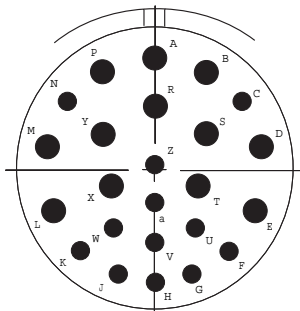

25-24  
12 # 12, 12 # 16, I

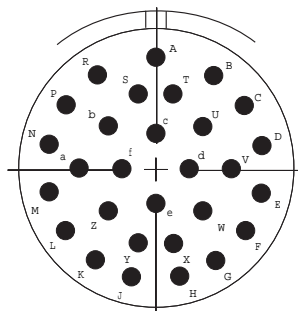

25-29  
29 # 16, I

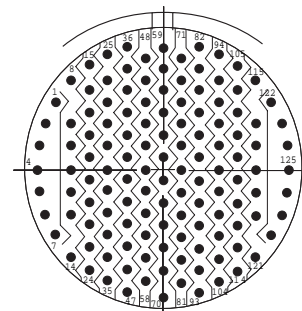

25-35  
128 # 22D, M

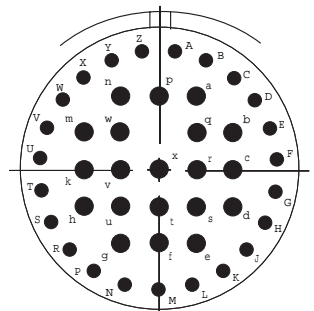

25-43  
20 # 16, 23 # 20, I

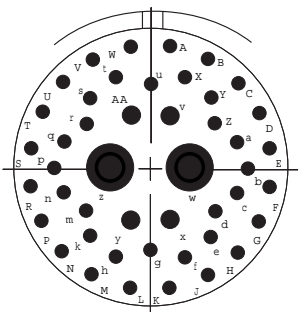

25-46  
40 # 20, 4 # 16, 2 # 8 Coax, I / Coax

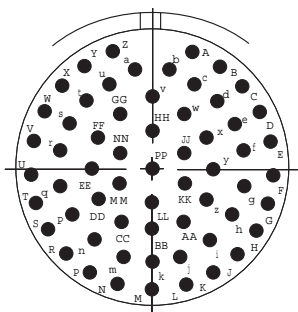

25-61  
61 # 20, I

## Features and Application

MIL-DTL-38999 Series II connectors feature a bayonet coupling mechanism with lower profile design and rear-removable crimp contact retention system.

These connectors were designed for military and commercial applications where the prime requirements are lower profile and lighter weight.

Reduction of both size and weight were achieved through the use of thinner shell walls and length restrictions. These design restrictions reduced the RFI attenuation characteristics and the “scoop” protection, while yielding an excellent general purpose, lightweight connector. Compared to Series I, Series II connectors achieve up to 20% reduction in mated pair length, up to 39% reduction in outside diameter and up to 40% reduction in weight (128 pin mated pair).

This family of connectors is offered in six receptacle-mounting styles. They include square flange receptacles, for both front and rear panel (wall) mounting; square flange receptacles, for both front and rear panel (box) mounting; square flange receptacle with extended grommet, for front of panel (box) mounting; and jam nut receptacles which incorporate “O” ring seals, designed for rear panel “D” hole mounting.

Plugs are available in two designs, with and without RFI grounding.

Fifty-two insert arrangement per MIL-STD-1560 are tooled and qualified to MIL-DTL-38999 Series II, utilizing 3 to 128 M39029 contacts. Contacts come in sizes 22D, 22M, 22, 20, 16 and 12, terminating wire sizes from 28 to 12 gauge.

These connectors are available in wide range of shell materials and finishes. Aluminum shells are offered in electroless nickel, bright cadmium, anodized, and olive drab cadmium. Other finishes such as zinc cobalt are available upon request to commercial callouts only. In addition, we offer passivated stainless steel shells with standard environment-resisting inserts (commercial callouts only).

**Universal I/R Tool** – A single, expendable plastic tool is used for both insertion and removal of contacts.

**Closed-Entry Socket Insert** – Hard dielectric socket face has lead-in chamfers for positive alignment of pins (even partially bent within pre-established limits) with sockets.

**Interfacial Pin Insert Seal** – Raised moisture barriers around each pin, which mate into lead-in chamfers of hard face socket insert, provide individual contact sealing. Interfacial seal is never touched by service tools.

**Elastomer Wire Sealing Grommet** – Sealing over a wide range of wire diameters is assured by a triple wire seal in each cavity at the rear of the connector.

**Superior Contact Stability** – Rear release crimp contact system features a stamped beryllium-copper retaining clip captivated by molded-in shoulders of each contact cavity in the insulator. A rear-inserted M81969 plastic tool expands the tines beyond the shoulder, releasing the contact.

**Shell Polarization** – Alternate key/keyway positions prevent cross mating of adjacent connectors having same insert arrangement.



**MIL-DTL-38999**  
**Performance Specifications**  
**Series II**



## Performance Specifications

### Operating Temperature Range

Finish B, Z\* and BN\*: -65°C to +175°C (-85°F to +347°F)  
 Finishes C, F & E\*: -65°C to +200°C (-85°F to +392°F)  
 Finish A: -65°C to +150°C (-85°F to 302°F)

### Material and Plating Data (Finish)

B – aluminum shell, olive drab cadmium over nickel base  
 C – aluminum shell, black anodized finish  
 F – aluminum shell, electroless nickel finish  
 A – aluminum shell, silver to light iridescent yellow color (bright) cadmium over electroless nickel base  
 BN\* - aluminum shell, black nickel finish (Aero p/n only)(RoHS)  
 Z\* - Aluminum shell, Black Zinc Nickel Finish (Aero p/n only) (RoHS)  
 E\* - stainless steel shell, passivated (Aero p/n only) (RoHS)

### Corrosion Resistance

Finishes A, B, C, E\* & Z\* withstand 500-hour salt spray.  
 Finish BN\* withstands 400 hour salt spray. Finish F withstands 48-hour salt spray.

### Durability

Mated connectors withstand a minimum of 250 mating cycles for RFI plug (MS27484) and 500 cycles for MS27473 and MS27500 plugs.

### Environmental Seal

Wired, mated connectors with specified accessories attached, shall meet the altitude-immersion test specified by MIL-DTL-38999.

### Fluid Resistance

Connectors resist specified immersions in MIL-PRF-7808, MIL-PRF-23699, MIL-PRF-5606, M2-V Chevron oil, Coolanol 25, MIL-DTL-83133 (JP-8), MIL-DTL-5624 (JP-4, JP-5), SAE-AMS1424 Type I, and other solvents and cleaning agents.

### Voltage Rating

Service Rating	Suggested Operating Voltage		Test Voltage	Test Voltage	Test Voltage	Test Voltage
	(Sea Level)		Sea Level	50,000 Ft.	70,000 Ft.	100,000 Ft.
	AC (RMS)	DC	V RMS	V RMS	V RMS	V RMS
M	400	550	1300	550	350	200
N	300	450	1000	400	260	200
I	600	850	1800	600	400	200
II	900	1250	2300	800	500	200

\*Not QPL'd, order via Aero part number only

### Shell-to-Shell Conductivity

Maximum potential drop shall not exceed:

- With RFI spring fingers, finish F & BN\* = 1.0 millivolt, while finishes A, B & Z\* = 2.5 millivolts. Finish E\* = 10.0 millivolts
- Without spring fingers = 200 millivolts.
- Finish C = nonconductive.

### Shielding Effectiveness

RFI and EMI attenuation at the specified frequencies meet the requirements of MIL-DTL-38999.

- RFI shielding effectiveness of mated connectors with RFI backshells is measured in a triaxial radio frequency leakage fixture.
- EMI shielding effectiveness is measured at the interface of mated connectors and tested by the mode-stirred technique specified in method 3008 of MIL-STD-1344.

### Shock and Vibration Requirements

Wired, mated connectors shall not be damaged, nor shall there be a current interruption longer than one microsecond when subjected to the following:

### Standard Shock

Mated connectors withstand a pulse of approximate half sine wave of 300 G magnitude with duration of three milliseconds applied in three axes per MIL-STD-1344, method 2004.

### Vibration

Mated connectors withstand the following vibration levels:

- Random vibration per MIL-STD-1344, method 2005 test condition VI, Letter "J".

**Note:** The establishment of electrical safety factors is left entirely to the designer, as he is in the best position to know

exactly what peak voltages, switching currents, transients, etc., can be expected in a particular circuit.



### Military and Aero-Electric Part Number Development

Mil. Prefix	MS	27473	T	12	B	35	P	A	
Aero Prefix	AE	273	T	12	B	35	P	A	-340
<b>Shell Type</b>									
27472 = Front, wall mount receptacle = 272 (Aero p/n)									
27473 = Straight plug = 273 (Aero p/n)									
27474 = Jam nut receptacle = 274 (Aero p/n)									
27484 = RFI grounding plug = 284 (Aero p/n)									
27497 = Rear, wall mount receptacle = 297 (Aero p/n)									
27499 = Front, box mount receptacle = 299 (Aero p/n)									
27500 = Standard plug with 90p backshell = 200 (Aero p/n)									
27508 = Rear, box mount receptacle = 208 (Aero p/n)									
27513 = Front, box mount rec. (long grommet) = 213 (Aero p/n)									
<b>Class</b>									
T = With accessory thread (MS27472, 27473, 27474, 27484 & 27497)									
E = Same as T in line above except connector is kitted with E-Nut									
= No accessory thread, box mount (MS27499 & MS27508)									
= No accessory thread, box mount, long grommet (MS27513)									
P = Supplied with ring and potting boot (same shell types as "T" class)									
<b>Shell Size</b>									
8, 10, 12, 14, 16, 18, 20, 22 or 24									
<b>Finish (Material &amp; Plating)</b>									
A = Aluminum shell, silver to light iridescent yellow (bright) cadmium over electroless nickel base									
B = Aluminum shell, olive drab cadmium over electroless nickel base									
C = Aluminum shell, black anodized finish (not available in MS27484)									
F = Aluminum shell, electroless nickel finish									
E = Stainless steel shell, passivated (Aero p/n only, n/a in AE284)									
BN = Aluminum shell, Black Nickel Finish (Aero p/n only)(RoHS)									
Z = Aluminum shell, Black Zinc Nickel Finish (Aero p/n only)(RoHS)									
<b>Insert Arrangement</b>									
See page 41-43									
<b>Contact Designator</b>									
P = Pin      A = Pin connector less pins (with intent to use non-std pin contacts)									
S = Socket    B = Socket connector less sockets (with intent to use non-std socket contacts)									
<b>Polarization (Keying)</b>									
N = Normal (Omitted in part number)									
A, B, C, or D (B & C keyways are not available in shell size 8)									
<b>Modification (applies to Aero part numbers only)</b>									
01 = Less contacts (is not marked on the part)									
340 = Connector kitted with M85049/27-XXX E-nut									
341 = Connector kitted with M85049/49-2-XXX straight clamp									
342 = Connector kitted with M85049/47XXX right angle clamp									
Consult factory for other modifications									

38999 S II

**Note 1:** Each connector is furnished with contacts unless ordered less contacts (L/C) as follows: One spare contact for inserts requiring 2 through 26 of each contact and two spares for inserts with 27 or more contacts, and a minimum of one sealing plug up to 10% of the number contacts. One insertion/extraction tool for each contact size is also included.

**Note 2:** Proper part number marking has no "0" in front of single digit shell size (8) and no "0" in front of single digit layout. Example of each: J MS27472T8B35S and J MS27472T10B5S. In both "N" for normal is omitted. Please note that JAN or J marking is required immediately in front of MS number.

**MS27497**  
**Rear, Wall Mount Receptacle**  
**AE297**



**Bayonet Coupling, Crimp Removable, Rear Release, Low Profile/Light Weight**

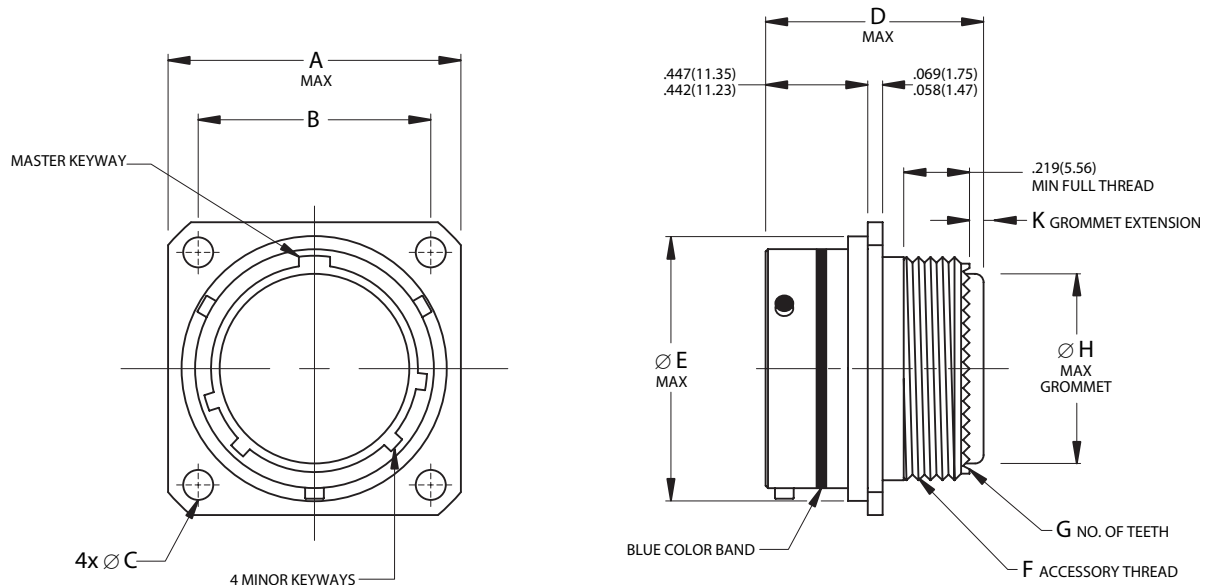

38999 S II

Page 24	Completed Part Number
Page 37	Contacts, Sealing Plugs and Tools
Pages 41–43	Insert Arrangements
Page 23	Performance Specifications
Pages 39, 40	Insert Availability and Contact Information
Page 35	Polarization

**Note:** See page 36 for panel thickness.

Shell Size	A		B		Ø C		D		Ø E		F	G	Ø H		K	
	Maximum		(TP)		+0.10	+0.25	Maximum		Maximum		Accessory Thread	No. of Teeth	Maximum		Grommet Extension	
	inch	mm	inch	mm	inch	mm	inch	mm	inch	mm	UNEF-2A		inch	mm	inch	mm
8	.828	21.03	.594	15.09	.120	3.05	.988	25.10	.547	13.89	7/16-28	12	.299	7.59	.150/.090	3.81/2.29
10	.954	24.23	.719	18.26	.120	3.05	.988	25.10	.672	17.07	9/16-24	16	.427	10.85	.150/.090	3.81/2.29
12	1.047	26.59	.812	20.62	.120	3.05	.988	25.10	.844	21.44	11/16-24	20	.541	13.74	.150/.090	3.81/2.29
14	1.141	28.98	.906	23.01	.120	3.05	.988	25.10	.969	24.61	13/16-20	24	.666	16.92	.150/.090	3.81/2.29
16	1.234	31.34	.969	24.61	.120	3.05	.988	25.10	1.094	27.79	15/16-20	28	.791	20.09	.150/.090	3.81/2.29
18	1.328	33.73	1.062	26.97	.120	3.05	.988	25.10	1.219	30.96	1-1/16-18	32	.897	22.78	.150/.090	3.81/2.29
20	1.453	36.91	1.156	29.36	.120	3.05	.988	25.10	1.344	34.14	1-3/16-18	36	1.022	25.96	.150/.090	3.81/2.29
22	1.578	40.08	1.250	31.75	.120	3.05	.988	25.10	1.469	37.31	1-5/16-18	40	1.147	29.13	.150/.090	3.81/2.29
24	1.703	43.26	1.375	34.93	.147	3.73	1.056	26.82	1.594	40.49	1-7/16-18	44	1.272	32.31	.140/.040	3.56/1.02

Bayonet Coupling, Crimp Removable, Rear Release, Low Profile/Light Weight

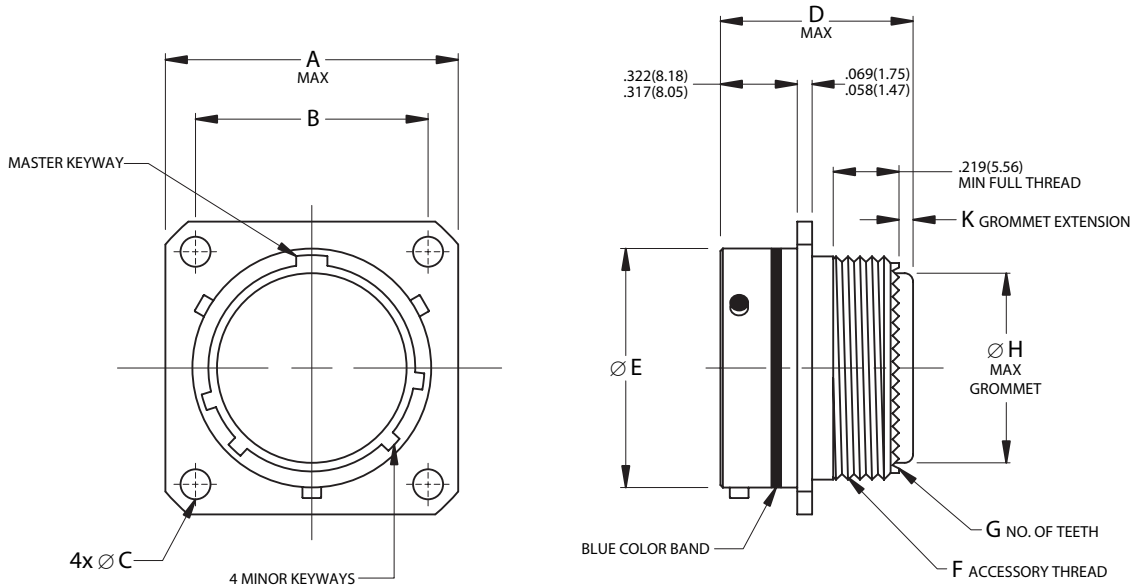

38999 S II

Page 24 Completed Part Number  
 Page 37 Contacts, Sealing Plugs and Tools  
 Pages 41–43 Insert Arrangements  
 Page 23 Performance Specifications  
 Pages 39, 40 Insert Availability and Contact Information  
 Page 35 Polarization

Shell Size	A		B		Ø C		D		Ø E		F	G	Ø H		K	
	Maximum		(TP)		+0.10	+0.25	Maximum		±.003	±.08	Accessory Thread	No. of Teeth	Maximum		Grommet Extension	
	inch	mm	inch	mm	inch	mm	inch	mm	inch	mm	UNEF-2A		inch	mm	inch	mm
8	.828	21.03	.594	15.09	.120	3.05	.932	23.67	.471	11.96	7/16-28	12	.299	7.59	.150/.090	3.81/2.29
10	.954	24.23	.719	18.26	.120	3.05	.932	23.67	.588	14.94	9/16-24	16	.427	10.85	.150/.090	3.81/2.29
12	1.047	26.59	.812	20.62	.120	3.05	.932	23.67	.748	19.00	11/16-24	20	.541	13.74	.150/.090	3.81/2.29
14	1.141	28.98	.906	23.01	.120	3.05	.932	23.67	.873	22.17	13/16-20	24	.666	16.92	.150/.090	3.81/2.29
16	1.234	31.34	.969	24.61	.120	3.05	.932	23.67	.998	25.35	15/16-20	28	.791	20.09	.150/.090	3.81/2.29
18	1.328	33.73	1.062	26.97	.120	3.05	.932	23.67	1.123	28.52	1-1/16-18	32	.897	22.78	.150/.090	3.81/2.29
20	1.453	36.91	1.156	29.36	.120	3.05	.932	23.67	1.248	31.70	1-3/16-18	36	1.022	25.96	.150/.090	3.81/2.29
22	1.578	40.08	1.250	31.75	.120	3.05	.932	23.67	1.373	34.87	1-5/16-18	40	1.147	29.13	.150/.090	3.81/2.29
24	1.703	43.26	1.375	34.93	.147	3.73	1.000	25.40	1.498	38.05	1-7/16-18	44	1.272	32.31	.140/.040	3.56/1.02

**MS27508**  
**Rear, Box Mount Receptacle**  
**AE208**



**Bayonet Coupling, Crimp Removable, Rear Release, Low Profile/Light Weight**

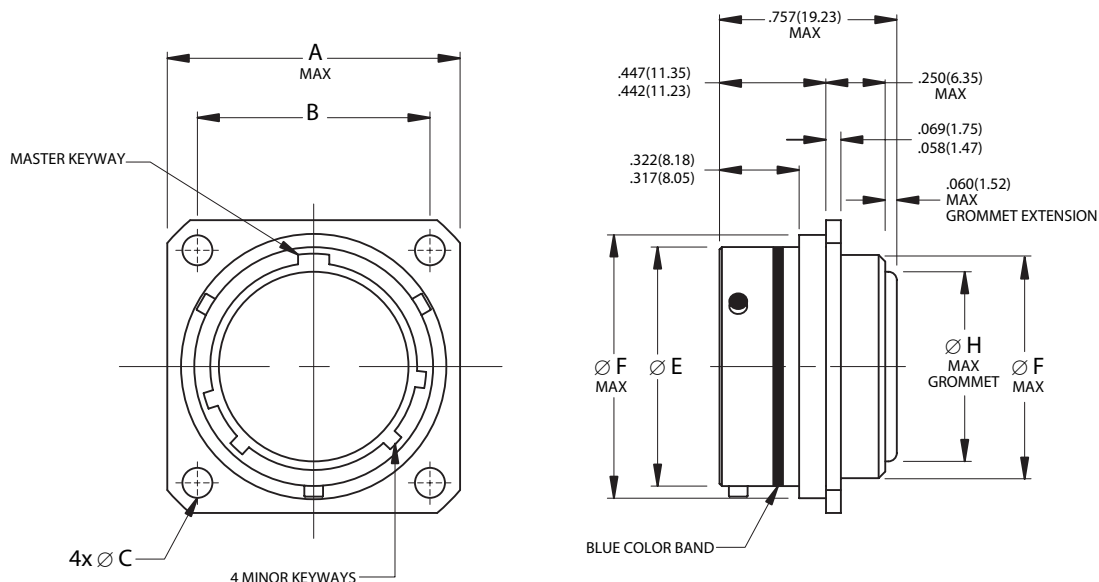

38999 S II

Page 24	Completed Part Number
Page 37	Contacts, Sealing Plugs and Tools
Pages 41–43	Insert Arrangements
Page 23	Performance Specifications
Pages 39, 40	Insert Availability and Contact Information
Page 35	Polarization

**Note:** See page 36 for panel thickness.

Shell Size	A		B		Ø C		Ø E		Ø F		Ø H	
	Maximum		(TP)		+010	+25	±003	±08	Maximum		Maximum	
	inch	mm	inch	mm	inch	mm	inch	mm	inch	mm	inch	mm
8	.828	21.03	.594	15.09	.120	3.05	.471	11.96	.547	13.89	.299	7.59
10	.954	24.23	.719	18.26	.120	3.05	.588	14.94	.672	17.07	.427	10.85
12	1.047	26.59	.812	20.62	.120	3.05	.748	19.00	.844	21.44	.541	13.74
14	1.141	28.98	.906	23.01	.120	3.05	.873	22.17	.969	24.61	.666	16.92
16	1.234	31.34	.969	24.61	.120	3.05	.998	25.35	1.094	27.79	.791	20.09
18	1.328	33.73	1.062	26.97	.120	3.05	1.123	28.52	1.219	30.96	.897	22.78
20	1.453	36.91	1.156	29.36	.120	3.05	1.248	31.70	1.344	34.14	1.022	25.96
22	1.578	40.08	1.250	31.75	.120	3.05	1.373	34.87	1.469	37.31	1.147	29.13
24	1.703	43.26	1.375	34.93	.147	3.73	1.498	38.05	1.594	40.49	1.272	32.31



**Bayonet Coupling, Crimp Removable, Rear Release, Low Profile/Light Weight**

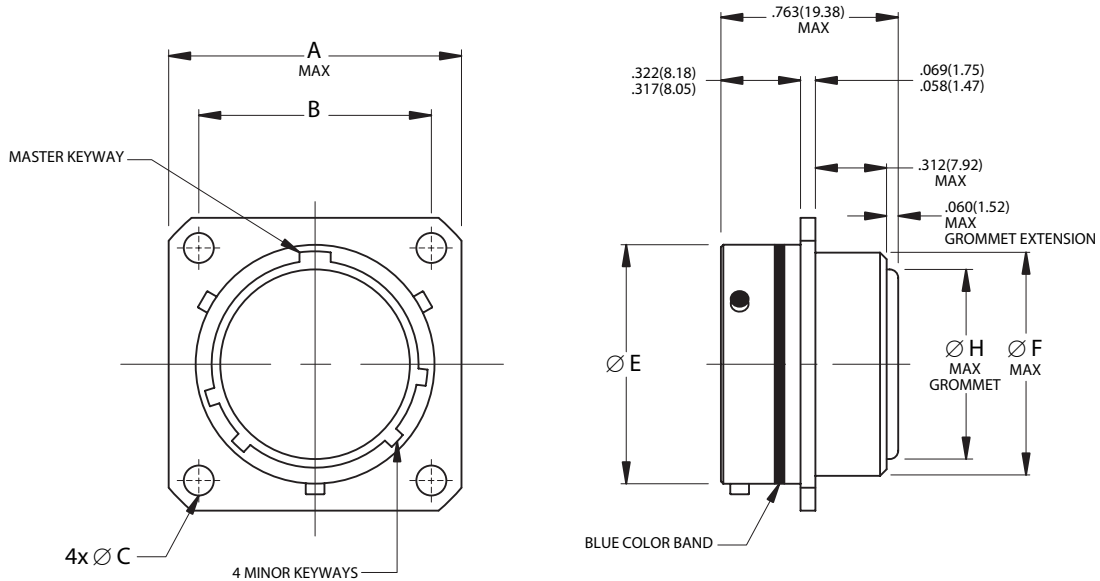

38999 S II

Page 24	Completed Part Number
Page 37	Contacts, Sealing Plugs and Tools
Pages 41–43	Insert Arrangements
Page 23	Performance Specifications
Pages 39, 40	Insert Availability and Contact Information
Page 35	Polarization

Shell Size	A		B		Ø C		Ø E		Ø F		Ø H	
	Maximum		(TP)		+010 -005	+25 -13	±003	±08	Maximum		Maximum	
	inch	mm	inch	mm	inch	mm	inch	mm	inch	mm	inch	mm
8	.828	21.03	.594	15.09	.120	3.05	.471	11.96	.453	11.51	.299	7.59
10	.954	24.23	.719	18.26	.120	3.05	.588	14.94	.578	14.68	.427	10.85
12	1.047	26.59	.812	20.62	.120	3.05	.748	19.00	.703	17.86	.541	13.74
14	1.141	28.98	.906	23.01	.120	3.05	.873	22.17	.828	21.03	.666	16.92
16	1.234	31.34	.969	24.61	.120	3.05	.998	25.35	.953	24.21	.791	20.09
18	1.328	33.73	1.062	26.97	.120	3.05	1.123	28.52	1.062	26.97	.897	22.78
20	1.453	36.91	1.156	29.36	.120	3.05	1.248	31.70	1.188	30.18	1.022	25.96
22	1.578	40.08	1.250	31.75	.120	3.05	1.373	34.87	1.312	33.32	1.147	29.13
24	1.703	43.26	1.375	34.93	.147	3.73	1.498	38.05	1.438	36.53	1.272	32.31



**MS27474**  
**Jam Nut Receptacle**  
**AE274**



**Bayonet Coupling, Crimp Removable, Rear Release, Low Profile/Light Weight**

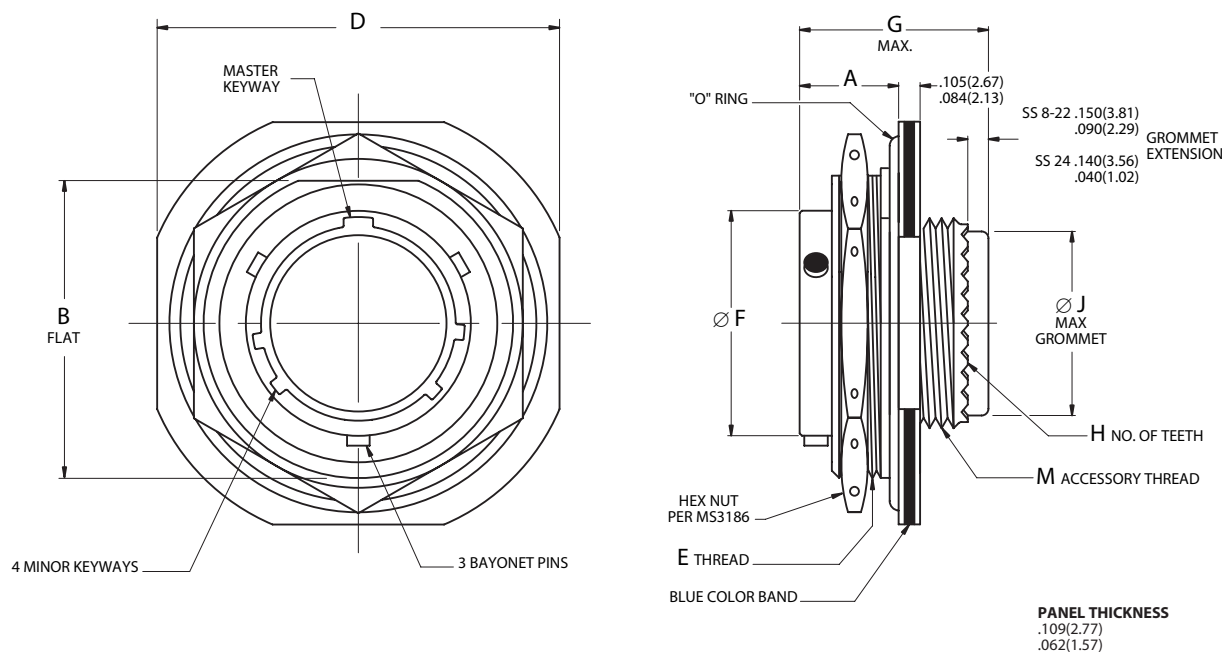

38999 S II

Page 24 Completed Part Number  
 Page 37 Contacts, Sealing Plugs and Tools  
 Pages 41–43 Insert Arrangements  
 Page 23 Performance Specifications  
 Pages 39, 40 Insert Availability and Contact Information  
 Page 35 Polarization

Shell Size	A		B		D		E	Ø F		G		H	Ø J		M
	±.005	±.13	+0.01	+0.03	±.016	±.41	Jam Nut Thread Class 2A	±.003	±.08	Maximum	No. of Teeth	Maximum	Maximum	Accessory Thread	
	inch	mm	inch	mm	inch	mm		inch	mm	inch	mm	inch	mm	UNEF-2A	
8	.438	11.13	.817	20.75	1.250	31.75	7/8-20UNEF	.471	11.96	.937	23.80	12	.299	7.59	7/16-28
10	.438	11.13	.941	23.90	1.375	34.93	1-20UNEF	.588	14.94	.937	23.80	16	.427	10.85	9/16-24
12	.438	11.13	1.065	27.05	1.500	38.10	1-1/8-18UNEF	.748	19.00	.937	23.80	20	.541	13.74	11/16-24
14	.438	11.13	1.190	30.23	1.625	41.28	1-1/4-18UNEF	.873	22.17	.937	23.80	24	.666	16.92	13/16-20
16	.438	11.13	1.320	33.53	1.781	45.24	1-3/8-18UNEF	.998	25.35	.937	23.80	28	.791	20.09	15/16-20
18	.438	11.13	1.440	36.58	1.890	48.01	1-1/2-18UNEF	1.123	28.52	.937	23.80	32	.897	22.78	1-1/16-18
20	.464	11.79	1.565	39.75	2.016	51.21	1-5/8-18UNEF	1.248	31.70	.931	23.65	36	1.022	25.96	1-3/16-18
22	.464	11.79	1.690	42.93	2.140	54.36	1-3/4-18UNS	1.373	34.87	.931	23.65	40	1.147	29.13	1-5/16-18
24	.464	11.79	1.815	46.10	2.265	57.53	1-7/8-16UN	1.498	38.05	.984	24.99	44	1.272	32.31	1-7/16-18

**Bayonet Coupling, Crimp Removable, Rear Release, Low Profile/Light Weight**

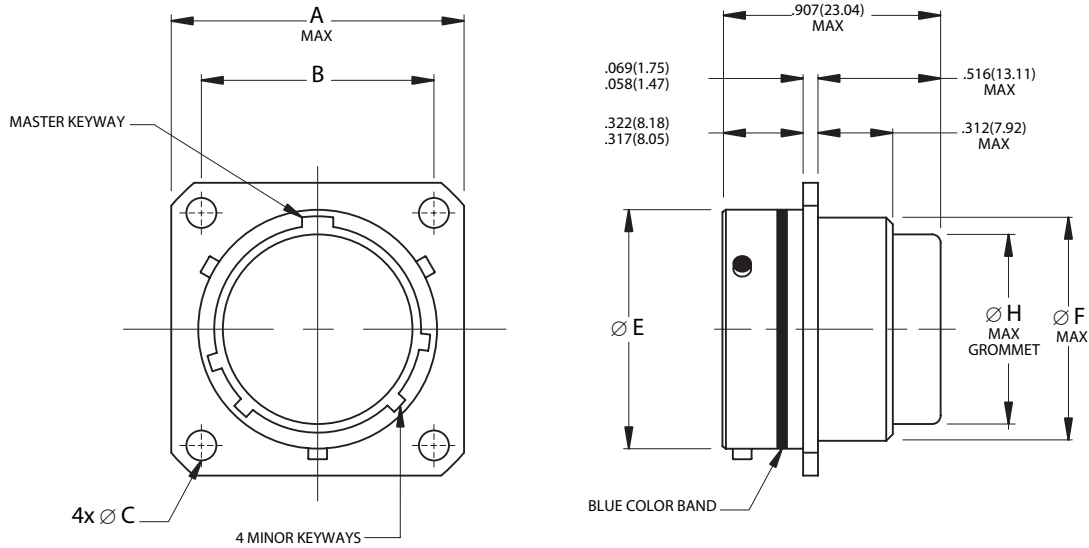

38999 S II

Page 24	Completed Part Number
Page 37	Contacts, Sealing Plugs and Tools
Pages 41–43	Insert Arrangements
Page 23	Performance Specifications
Pages 39, 40	Insert Availability and Contact Information
Page 35	Polarization

Shell Size	A		B		Ø C		Ø E		Ø F		Ø H	
	Maximum		(TP)		+0.01 -0.005	+0.25 -0.13	±0.003	±0.08	Maximum		Maximum	
	inch	mm	inch	mm	inch	mm	inch	mm	inch	mm	inch	mm
8	.828	21.03	.594	15.09	.120	3.05	.471	11.96	.453	11.51	.299	7.59
10	.954	24.23	.719	18.26	.120	3.05	.588	14.94	.578	14.68	.427	10.85
12	1.047	26.59	.812	20.62	.120	3.05	.748	19.00	.703	17.86	.541	13.74
14	1.141	28.98	.906	23.01	.120	3.05	.873	22.17	.828	21.03	.666	16.92
16	1.234	31.34	.969	24.61	.120	3.05	.998	25.35	.953	24.21	.791	20.09
18	1.328	33.73	1.062	26.97	.120	3.05	1.123	28.52	1.062	26.97	.897	22.78
20	1.453	36.91	1.156	29.36	.120	3.05	1.248	31.70	1.188	30.18	1.022	25.96
22	1.578	40.08	1.250	31.75	.120	3.05	1.373	34.87	1.312	33.32	1.147	29.13
24	1.703	43.26	1.375	34.93	.147	3.73	1.498	38.05	1.438	36.53	1.272	32.31

**MS27473**  
**Straight Plug**  
**AE273**



**Bayonet Coupling, Crimp Removable, Rear Release, Low Profile/Light Weight**

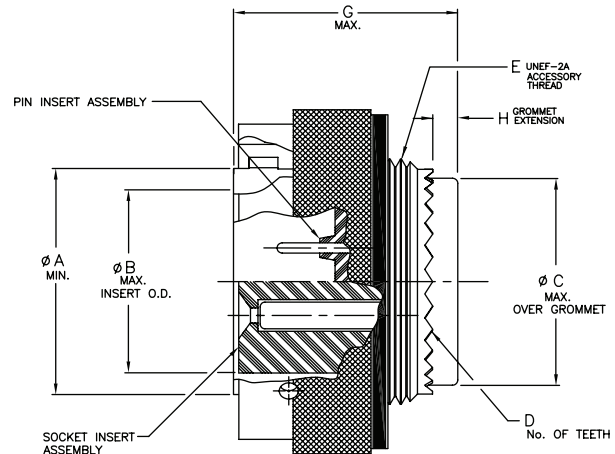
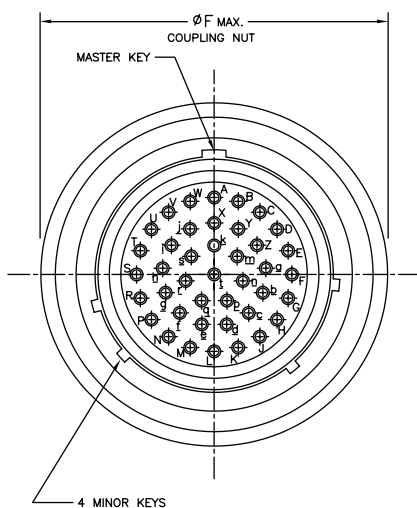

38999 S II

Page 24	Completed Part Number
Page 37	Contacts, Sealing Plugs and Tools
Pages 41–43	Insert Arrangements
Page 23	Performance Specifications
Pages 39, 40	Insert Availability and Contact Information
Page 35	Polarization

Shell Size	Ø A		Ø C		D	E	Ø F		G		H	
	Minimum		Maximum				No of Teeth	Accessory Thread	Maximum		Maximum	
	inch	mm	inch	mm	UNEf-2A	inch			mm	inch	mm	inch
8	.337	<b>8.56</b>	.299	<b>7.59</b>	12	7/16-28	.750	<b>19.05</b>	.916	<b>23.27</b>	.150/.090	<b>3.81/2.29</b>
10	.465	<b>11.81</b>	.427	<b>10.85</b>	16	9/16-24	.859	<b>21.82</b>	.916	<b>23.27</b>	.150/.090	<b>3.81/2.29</b>
12	.557	<b>14.15</b>	.541	<b>13.74</b>	20	11/16-24	1.031	<b>26.19</b>	.916	<b>23.27</b>	.150/.090	<b>3.81/2.29</b>
14	.702	<b>17.83</b>	.666	<b>16.92</b>	24	13/16-20	1.156	<b>29.36</b>	.916	<b>23.27</b>	.150/.090	<b>3.81/2.29</b>
16	.827	<b>21.01</b>	.791	<b>20.09</b>	28	15/16-20	1.281	<b>32.54</b>	.916	<b>23.27</b>	.150/.090	<b>3.81/2.29</b>
18	.927	<b>23.55</b>	.897	<b>22.78</b>	32	1-1/16-18	1.406	<b>35.71</b>	.916	<b>23.27</b>	.150/.090	<b>3.81/2.29</b>
20	1.052	<b>26.72</b>	1.022	<b>25.96</b>	36	1-3/16-18	1.531	<b>38.89</b>	.916	<b>23.27</b>	.150/.090	<b>3.81/2.29</b>
22	1.177	<b>29.90</b>	1.147	<b>29.13</b>	40	1-5/16-18	1.641	<b>41.68</b>	.916	<b>23.27</b>	.150/.090	<b>3.81/2.29</b>
24	1.302	<b>33.07</b>	1.272	<b>32.31</b>	44	1-7/16-18	1.766	<b>44.86</b>	.984	<b>24.99</b>	.140/.040	<b>3.56/1.02</b>

**Bayonet Coupling, Crimp Removable, Rear Release, Low Profile/Light Weight**

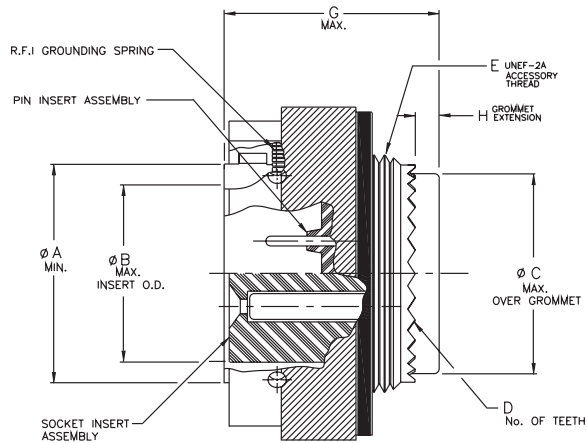
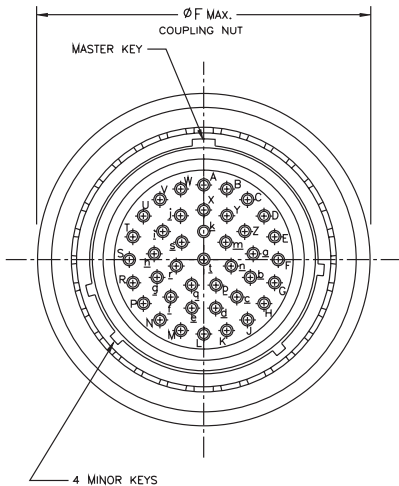

38999 S II

- Page 24 Completed Part Number
- Page 37 Contacts, Sealing Plugs and Tools
- Pages 41–43 Insert Arrangements
- Page 23 Performance Specifications
- Pages 39, 40 Insert Availability and Contact Information
- Page 35 Polarization

Shell Size	Ø A		Ø C		D	E	Ø F		G		H	
	Minimum		Maximum				No of Teeth	Accessory Thread	Maximum		Maximum	
	inch	mm	inch	mm	UNE-F-2A	inch			mm	inch	mm	inch
8	.337	<b>8.56</b>	.299	<b>7.59</b>	12	7/16-28	.750	<b>19.05</b>	.916	<b>23.27</b>	.150/.090	<b>3.81/2.29</b>
10	.465	<b>11.81</b>	.427	<b>10.85</b>	16	9/16-24	.859	<b>21.82</b>	.916	<b>23.27</b>	.150/.090	<b>3.81/2.29</b>
12	.557	<b>14.15</b>	.541	<b>13.74</b>	20	11/16-24	1.031	<b>26.19</b>	.916	<b>23.27</b>	.150/.090	<b>3.81/2.29</b>
14	.702	<b>17.83</b>	.666	<b>16.92</b>	24	13/16-20	1.156	<b>29.36</b>	.916	<b>23.27</b>	.150/.090	<b>3.81/2.29</b>
16	.827	<b>21.01</b>	.791	<b>20.09</b>	28	15/16-20	1.281	<b>32.54</b>	.916	<b>23.27</b>	.150/.090	<b>3.81/2.29</b>
18	.927	<b>23.55</b>	.897	<b>22.78</b>	32	1-1/16-18	1.406	<b>35.71</b>	.916	<b>23.27</b>	.150/.090	<b>3.81/2.29</b>
20	1.052	<b>26.72</b>	1.022	<b>25.96</b>	36	1-3/16-18	1.531	<b>38.89</b>	.916	<b>23.27</b>	.150/.090	<b>3.81/2.29</b>
22	1.177	<b>29.90</b>	1.147	<b>29.13</b>	40	1-5/16-18	1.641	<b>41.68</b>	.916	<b>23.27</b>	.150/.090	<b>3.81/2.29</b>
24	1.302	<b>33.07</b>	1.272	<b>32.31</b>	44	1-7/16-18	1.766	<b>44.86</b>	.984	<b>24.99</b>	.140/.040	<b>3.56/1.02</b>

**MS27500**  
**Plug with 90° Backshell**  
**AE200**



**Bayonet Coupling, Crimp Removable, Rear Release, Low Profile/Light Weight**

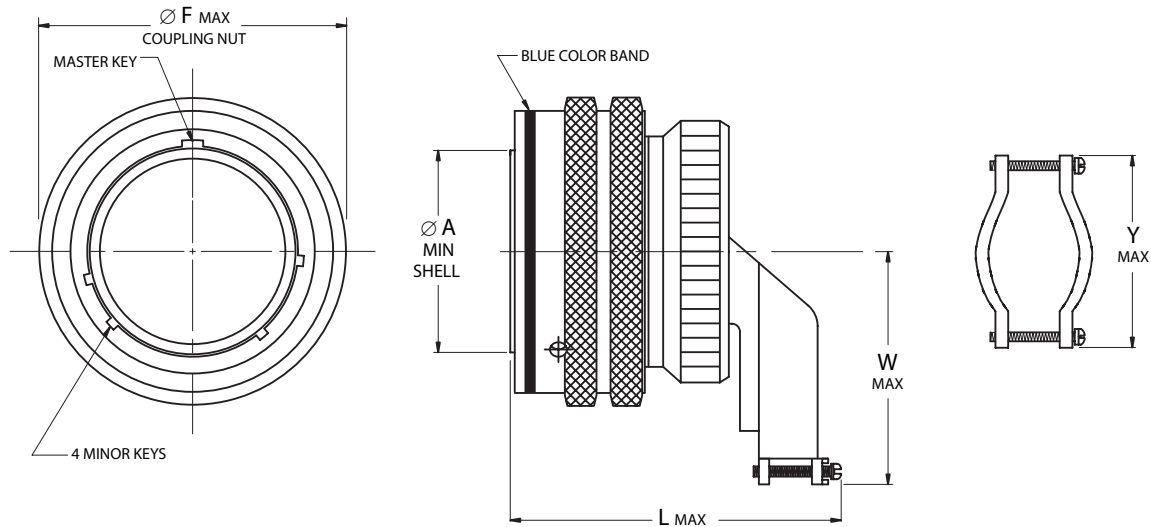

38999 S II

Page 24	Completed Part Number
Page 37	Contacts, Sealing Plugs and Tools
Pages 41–43	Insert Arrangements
Page 23	Performance Specifications
Pages 39, 40	Insert Availability and Contact Information
Page 35	Polarization

Shell Size	Ø A		Ø F		L		W		Y	
	Minimum		Maximum		Maximum		Maximum		Maximum	
	inch	mm	inch	mm	inch	mm	inch	mm	inch	mm
8	.337	8.56	.750	19.05	1.859	47.22	1.000	25.40	.828	21.03
10	.465	11.81	.859	21.82	1.859	47.22	1.032	26.21	.891	22.63
12	.557	14.15	1.031	26.19	1.938	49.23	1.094	27.79	1.016	25.81
14	.702	17.83	1.156	29.36	2.125	53.98	1.219	30.96	1.141	28.98
16	.827	21.01	1.281	32.54	2.281	57.94	1.281	32.54	1.255	31.88
18	.927	23.55	1.406	35.71	2.312	58.72	1.344	34.14	1.469	37.31
20	1.052	26.72	1.531	38.89	2.375	60.33	1.375	34.93	1.550	39.37
22	1.177	29.90	1.641	41.68	2.531	64.29	1.438	36.53	1.675	42.55
24	1.302	33.07	1.766	44.86	2.828	71.83	1.719	43.66	1.800	45.72

**Dummy Stowage Receptacle, Bayonet Coupling**

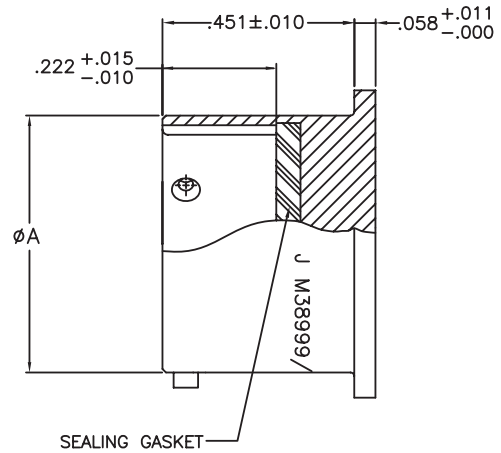
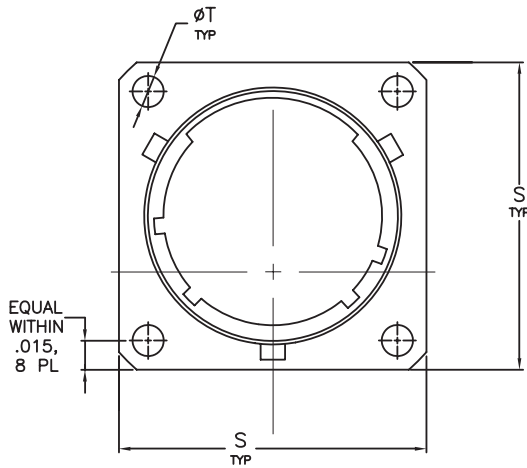

38999 S II

**Part Number Configuration**

<b>MIL. Prefix</b>	<b>M38999/</b>	<b>10</b>	<b>XX</b>	<b>B</b>
<b>Aero Prefix</b>	<b>AE2</b>	<b>10-</b>	<b>XX</b>	<b>B</b>
<b>Shell Type</b>				
10 = receptacle, dummy stowage, bayonet coupling				
<b>Shell Size</b>				
8 THRU 24 (Note: single digit for shell size 8)				
<b>Material Finish</b>				
B = Aluminum, Cadmium Olive Drab				
A = Aluminum, Bright Cadmium over Nickel base (Aero p/n only)				
F = Aluminum shell, Electroless Nickel finish (Aero p/n only)				
S = Stainless steel shell, passivated (Aero p/n only)				
BN = Aluminum, Black Nickel (Aero p/n only)				
BZ = Bronze (Aero p/n only)				
Z = Aluminum shell, Black Zinc Nickel (Aero p/n only)				
C = Aluminum shell, black anodized (Aero part # only)				

SHELL SIZE	ø A +.001 -.005	ø T +.010 -.005	S MAX
8	.473	.120	.828
10	.590	.120	.954
12	.750	.120	1.047
14	.875	.120	1.141
16	1.000	.120	1.234
18	1.125	.120	1.328
20	1.250	.120	1.453
22	1.375	.120	1.578
24	1.500	.147	1.703

### Keying Positions

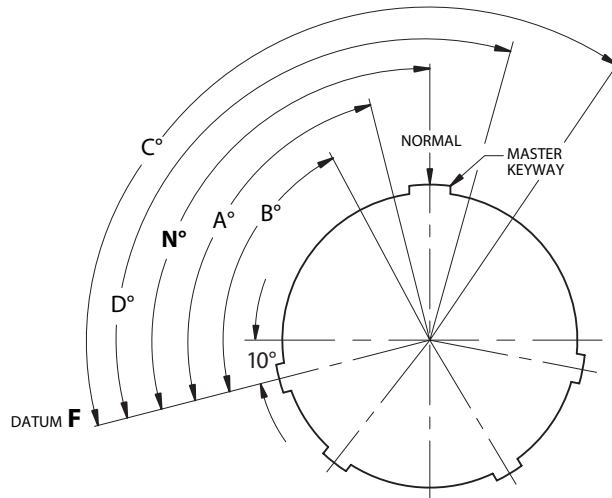

38999 S II

**Notes:**

1. Mating face of receptacle shown (plug is opposite).
2. The master keyway (key) has various positions relative to DATUM **F**; the minor keyways (keys) remain fixed as shown. In the Normal position, the master keyway (key) is 100° from DATUM **F**.
3. The angles for a given connector are the same whether it contains pin or socket inserts.
4. The insert arrangement does not rotate relative to master keyway (key).

Shell Size	Keying Positions				
	BSC				
	N°	A°	B°	C°	D°
8	100	82	-	-	118
10	100	86	72	128	114
12	100	80	68	132	120
14	100	79	66	134	121
16	100	82	70	130	118
18	100	82	70	130	118
20	100	82	70	130	118
22	100	85	74	126	115
24	100	85	74	126	115

**Panel Cutouts**

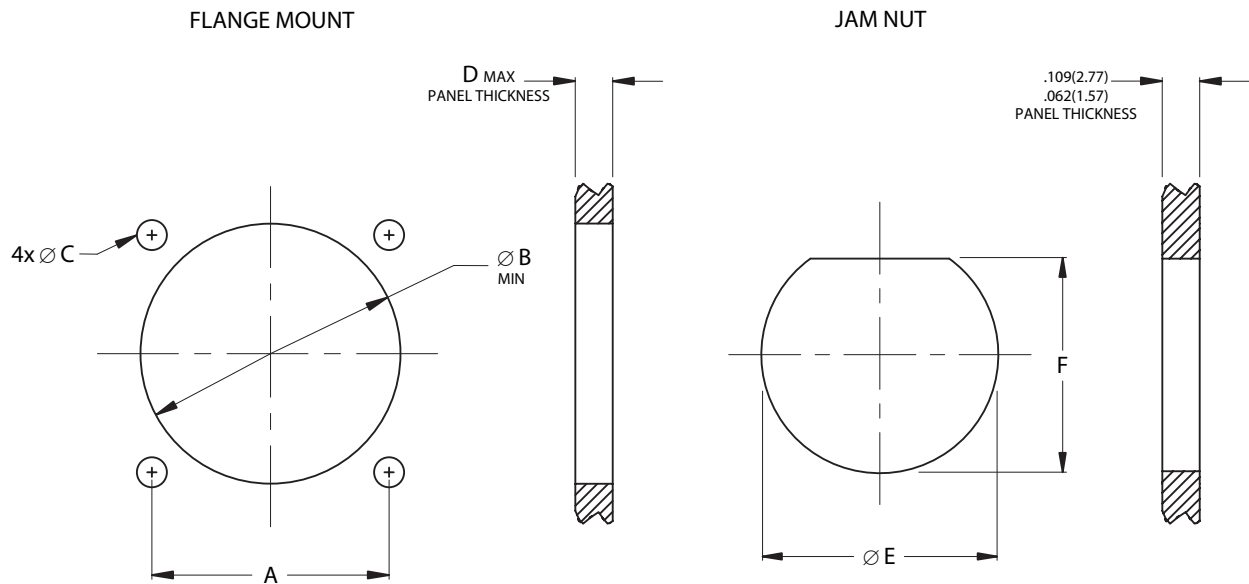

38999 S II

**Note 1:** Flange Mounting Dimensions ( $\varnothing B$  cutout and  $D_{MAX}$ ) listed only for back of panel mounting (MS27497 and MS27508).

**Note 2:**  $D_{MAX}$  includes mounting hardware.

**Flange and Jam Nut Mounting Dimensions**

Shell Size	A		$\varnothing B$		$\varnothing C$		D		$\varnothing E$		F	
	(TP)		Minimum		$\pm .005$	$\pm .13$	Maximum		$+ .010$	$+ .25$	$+ .000$	$+ .00$
	inch	mm	inch	mm	inch	mm	inch	mm	inch	mm	inch	mm
8	.594	15.09	.557	14.15	.128	3.25	.146	3.71	.885	22.48	.830	21.08
10	.719	18.26	.682	17.32	.128	3.25	.146	3.71	1.010	25.65	.955	24.26
12	.812	20.62	.854	21.69	.128	3.25	.146	3.71	1.135	28.83	1.085	27.56
14	.906	23.01	.979	24.87	.128	3.25	.146	3.71	1.260	32.01	1.210	30.73
16	.969	24.61	1.104	28.04	.128	3.25	.146	3.71	1.385	35.18	1.335	33.91
18	1.062	26.97	1.229	31.22	.128	3.25	.146	3.71	1.510	38.35	1.460	37.08
20	1.156	29.36	1.354	34.39	.128	3.25	.168	4.27	1.635	41.53	1.585	40.26
22	1.250	31.75	1.479	37.57	.128	3.25	.168	4.27	1.760	44.70	1.709	43.42
24	1.375	34.93	1.604	40.74	.154	3.91	.168	4.27	1.885	47.88	1.835	46.61



# MIL-DTL-38999

## Contacts, Tools and Seal Plugs

### Series II



#### Contacts, Plastic Insertion/Removal Tools and Seal Plugs

Contact Size	Application	Pin Contacts	Socket Contacts	Seal Plugs	Insertion/Removal Tools
	Type	Military No.	Military No.	Military No.	Military No.
22D	Power/Signal	M39029/58-360	M39029/57-354	MS27488-22-1	M81969/14-01
22M*	Power/Signal	M39029/58-361	M39029/57-355		—
22*	Power/Signal	M39029/58-362	M39029/57-356		—
20	Power/Signal	M39029/58-363	M39029/57-357	MS27488-20-1	M81969/14-10
16	Power/Signal	M39029/58-364	M39029/57-358	MS27488-16-1	M81969/14-03
16 Coax	Coax	M39029/76-424	M39029/78-432		
12	Power/Signal	M39029/58-365	M39029/57-359	MS27488-12-1	M81969/14-04

#### Crimping and Metal Insertion/Extraction Tools

Contact Size/Type	Crimp Tool	Positioner	Positioner	Insertion Tool	Extraction Tool
	Military No.	Military No.	Military No.	Military No.	Military No.
22D, 22M*	M22520/2-01	M22520/2-09	M22520/2-06	M81969/8-01	M81969/8-02
22*	M22520/2-01	M22520/2-09	M22520/2-06	M81969/8-03	M81969/8-04
20	M22520/1-01	M22520/1-04	M22520/1-04	M81969/8-05	M81969/8-06
	M22520/2-01	M22520/2-10	M22520/2-10		
16	M22520/1-01	M22520/1-04	M22520/1-04	M81969/8-07	M81969/8-08
16 Coax Inner	M22520/2-01	M22520/2-35	M22520/2-35		
16 Coax Outer	M22520/4-01	M22520/4-02	M22520/4-02		
12	M22520/1-01	M22520/1-04	M22520/1-04	M81969/8-09	M81969/8-10

#### Contact and Wire Data

Contact Size	Test Current	Voltage	Crimp Well Data			Wire Range		Finished Wire Ø Range			
	DC Test	Max. Drop	Well Dia.	Minimum Well Dept		AWG	mm <sup>2</sup>	Minimum		Maximum	
	Amps	Millivolts	inch	inch	mm			inch	mm	inch	mm
22D	5.0	73	.0345 ±.0010	.141	3.58	28-22	.08-.33	.030	.76	.054	1.37
22M*	3.0	45	.028 ±.001	.141	3.58	28-24	.08-.20	.030	.76	.050	1.27
22*	5.0	73	.0365 ±.0010	.141	3.58	26-22	.13-.33	.034	.86	.060	1.52
20	7.5	55	.047 ±.001	.209	5.31	24-20	.20-.52	.040	1.02	.083	2.11
16	13.0	49	.067 ±.001	.209	5.31	20-16	.52-1.31	.065	1.65	.109	2.77
12	23.0	42	.100 ±.002	.209	5.31	14-12	2.08-3.31	.097	2.46	.142	3.61

\* Inactive for new design

**Note 1:** Test Current and Maximum Voltage Drop when tested with silver-plated wire at 25°C.

**Note 2:** Size 16 coax contacts purchased in bulk.



MIL-DTL-38999

## Contact Installation Instructions Series II

38999 S II

# Contact Installation Instructions

### Crimping Contacts

1. Select the appropriate crimp tool and ensure that the proper crimp head positioner is used.
2. Cycle the tool to be sure the indentors are open.
3. Determine the correct selector setting for the wire size from the data plate on the positioner (turret head assembly) and set the selector knob on the crimp tool to match.
4. Place the contact, mating end first, into the tool.
5. Insert the stripped wire into the hollow end of the contact. Be sure the wire is inserted as far as it will go.
6. Close the tool completely to crimp. Unless the tool is closed completely, the tool will not release the contact.
7. Remove the crimped contact from the tool. Check the inspection hole to verify that the wire is fully inserted.

### Insertion of Contacts

1. Before inserting the contacts, unscrew the accessories (clamps, backshells or adapters) from rear of plug or receptacle. Slide the hardware over the wire bundle in the proper order for reassembly after all the contacts are inserted.
2. To assist insertion of contacts, lubricate insulator (grommet) cavities with isopropyl alcohol. Alcohol will evaporate and will not leave a conductive film. **Caution: Never use any lubricant other than isopropyl alcohol.**

3. Place the correct insertion tool on the contact so that the wire runs along the groove in the tool. (Tool tip will butt against the shoulder.) Hold the plug or receptacle body firmly.
4. Beginning with a center cavity, insert the contact into the insulator with a slow, even pressure until the contact snaps into position. Make sure the contact and tool are held perpendicular to the face of the insert during the contact installation or the grommet could be damaged.
  - 4.1 If contacts are not inserted all the way prior to removing insertion tool, do not try to reinsert the insertion tool. Instead, remove the contact and try again; otherwise reinserting the insertion tool may damage the inside of the contact cavity.
5. Remove tool and check the face of the connector for proper contact installation. Proper installation may also be checked by pulling back lightly on the wire to make sure the contact is properly seated.

### Completion

After all the cavities have been filled, slide the hardware back into position on the connector and tighten.

### Extraction of Contacts (Rework)

1. Slide the hardware back over the wire bundle.
2. Select the appropriate tool. Place the wire into the extraction tool of the pin or socket.
3. Slowly slide the extraction tool down wire into the contact cavities until the tool tip bottoms against the contact shoulder, expanding the clip retaining tines. Hold the wire firmly in the tool and pull the wired contact and tool straight out of the rear of the insulator.

Size	Pin Contact	Socket Contact	Basic Crimp Tool	Pin Positioner	Socket Positioner	Insertion/Removal Tool
22D	M39029/58-360	M39029/57-354	M22520/2-01	M22520/2-09	M22520/2-06	M81969/14-01
22M	M39029/58-361	M39029/57-355	M22520/2-01	M22520/2-09	M22520/2-06	M81969/14-01
22	M39029/58-362	M39029/57-356	M22520/2-01	M22520/2-09	M22520/2-06	M81969/14-01
20	M39029/58-363	M39029/57-357	M22520/1-01	M22520/1-04 Red	M22520/1-04 Red	M81969/14-10
			M22520/2-01	M22520/2-10	M22520/2-10	
16	M39029/58-364	M39029/57-358	M22520/1-01	M22520/1-04 Blue	M22520/1-04 Blue	M81969/14-03
12	M39029/58-365	M39029/57-359	M22520/1-01	M22520/1-04 Yellow	M22520/1-04 Yellow	M81969/14-04

For coax contacts refer to instructions supplied with contacts.

**MIL-DTL-38999 Series II**  
**Insert Availability and Contact Information**  
**per MIL-STD-1560**



**Insert Availability and Contact Information**

Insert Arrangement	Aero-Electric		Service	Total	Quantity of Contacts					
	Status			No. of	(by Size)					
Series II	QPL'd	Tooled	Rating	Contacts	22D	22M	22	20	16	12
8-6*	Yes	Yes	M	6		6				
8-35	Yes	Yes	M	6	6					
8-98	Yes	Yes	I	3				3		
10-5	Yes	Yes	I	5				5		
10-13*	Yes	Yes	M	13		13				
10-35	Yes	Yes	M	13	13					
10-98	Yes	Yes	I	6				6		
10-99	Yes	Yes	I	7				7		
12-3	Yes	Yes	II	3					3	
12-4	Yes	Yes	I	4					4	
12-8	Yes	Yes	I	8				8		
12-22*	Yes	Yes	M	22		22				
12-35	Yes	Yes	M	22	22					
12-98	Yes	Yes	I	10				10		
14-5	Yes	Yes	II	5					5	
14-15	Yes	Yes	I	15				14	1	
14-18	Yes	Yes	I	18				18		
14-35	Yes	Yes	M	37	37					
14-37*	Yes	Yes	M	37		37				
14-97	Yes	Yes	I	12				8	4	
16-6	Yes	Yes	I	6						6
16-8	Yes	Yes	II	8					8	
16-26	Yes	Yes	I	26				26		
16-35	Yes	Yes	M	55	55					
16-55*	Yes	Yes	M	55		55				
16-99	Yes	Yes	I	23				21	2	
18-11	Yes	Yes	II	11					11	
18-28	Yes	Yes	I	28				26	2	
18-30	Yes	Yes	I	30				29	1	
18-32	Yes	Yes	I	32				32		
18-35	Yes	Yes	M	66	66					
18-53**	Yes	Yes	M	53			53			
18-66*	Yes	Yes	M	66		66				

See next page for Shell Sizes 20 thru 24 layouts.

\* Not approved for new design. Toolled and qualified but their separate pictorials are not shown on pages 41 thru 43, as they are the same as corresponding (-35) layouts that take the same quantity of 22D contacts, but are supplied with 22M contacts instead.

\*\* Not approved for new design. Pictorial is shown on page 42.



**MIL-DTL-38999 Series II**  
**Insert Availability and Contact Information**  
**per MIL-STD-1560**

**Insert Availability and Contact Information (continued)**

Insert Arrangement	Aero-Electric		Service	Total	Quantity of Contacts					
	Status			No. of	(by Size)					
	QPL'd	Tooled	Rating	Contacts	22D	22M	22	20	16	12
Series II										
20-1*	Yes	Yes	M	79		79				
20-16	Yes	Yes	II	16					16	
20-35	Yes	Yes	M	79	79					
20-39	Yes	Yes	I	39				37	2	
20-41	Yes	Yes	I	41				41		
22-1*	Yes	Yes	M	100		100				
22-2***	Yes	Yes	M	85			85			
22-21	Yes	Yes	II	21					21	
22-32	Yes	Yes	I	32				32		
22-35	Yes	Yes	M	100	100					
22-53	Yes	Yes	I	53				53		
22-55	Yes	Yes	I	55				55		
24-1*	Yes	Yes	M	128		128				
24-4	Yes	Yes	I	56				48	8	
24-19	Yes	Yes	I	19						19
24-24	Yes	Yes	I	24					12	12
24-29	Yes	Yes	I	29					29	
24-35	Yes	Yes	M	128	128					
24-61	Yes	Yes	I	61				61		

\* Not approved for new design. Tooled and qualified but their separate pictorials are not shown on pages 41 thru 43, as they are same as corresponding (-35) layouts that take the same quantity of 22D contacts, but are supplied with 22M contacts instead.

38999 S II

Insert Arrangements Views



8-35  
6 # 22D, M



8-98  
3 # 20, I

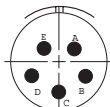

10-5  
5 # 20, I

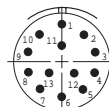

10-35  
13 # 22D, M

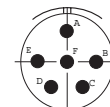

10-98  
6 # 20, I

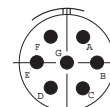

10-99  
7 # 20, I

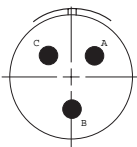

12-3  
3 # 16, II

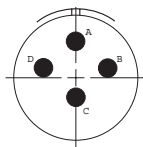

12-4  
4 # 16, I

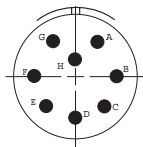

12-8  
8 # 20, I

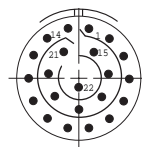

12-35  
22 # 22D, M

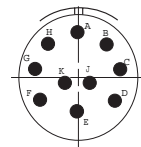

12-98  
10 # 20, I

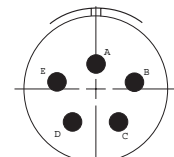

14-5  
5 # 16, II

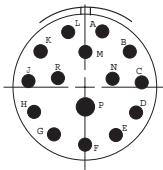

14-5  
1 # 16, 14 # 20, I

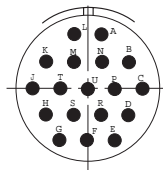

14-18  
18 # 20, I

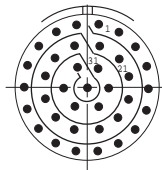

14-35  
37 # 22D, M

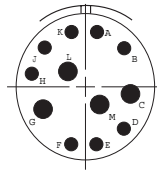

14-97  
4 # 16, 8 # 20, I

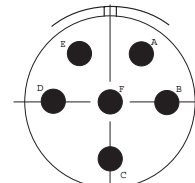

16-6  
6 # 12, I

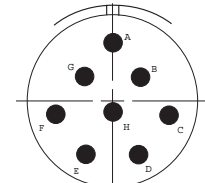

16-8  
8 # 16, II

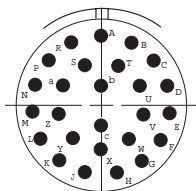

16-26  
26 # 20, I

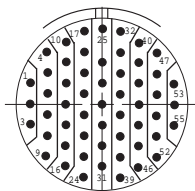

16-35  
55 # 22D, M

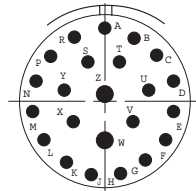

16-99  
2 # 16, 21 # 20, I

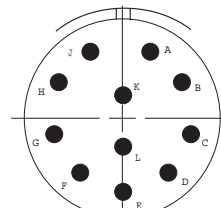

18-11  
11 # 16, II

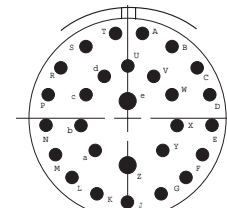

18-28  
2 # 16, 26 # 20, I

Insert Arrangements Views

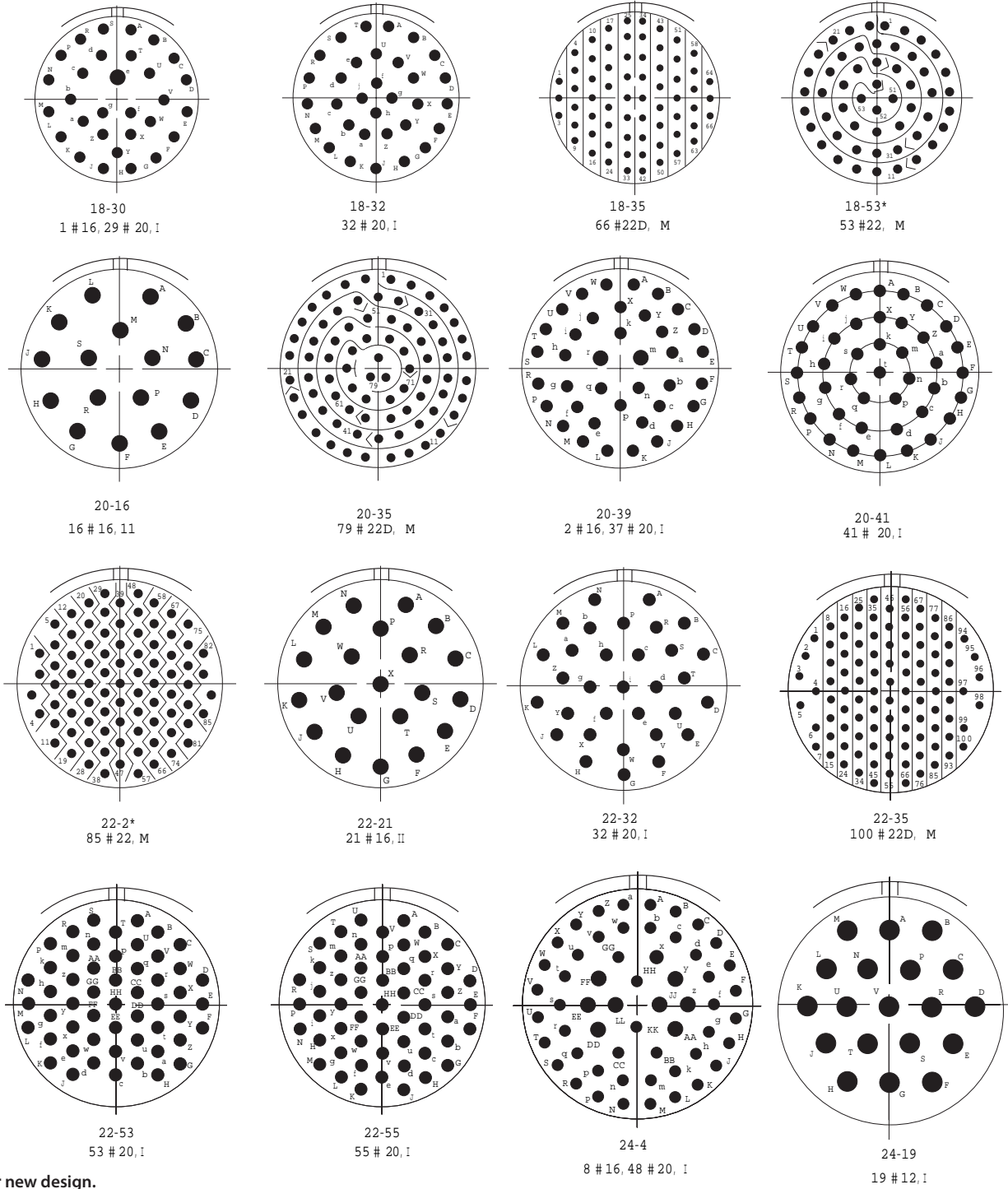

38999 S II

\* Inactive for new design.

\*\* Not MIL-STD-1560 layout (not QPL'd.).

MIL-STD-1560

Insert Arrangements (Pin Front View)  
for MIL-DTL-38999 Series II Connectors



Insert Arrangements Views

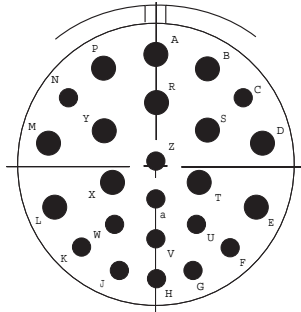

24-24  
12 # 12, 12 # 16, I

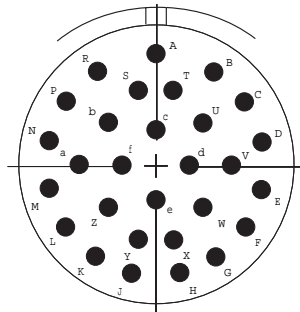

24-29  
29 # 16, I

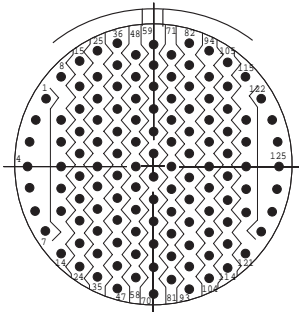

24-35  
128 # 22D, M

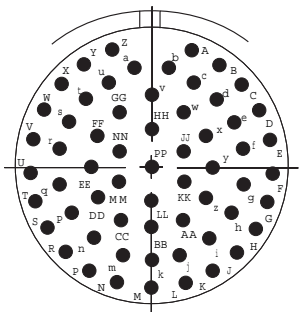

24-61  
61 # 20, I

38999 S II

## Features and Application

MIL-DTL-38999 Series III is the newest cylindrical connector designed for highest performance capabilities used in both general purpose and severe environment applications.

These connectors feature an improved “one-turn” coupling system, utilizing self-locking acme thread. Acme threads provide coupling durability, while thicker wall sections and greater coupling surface area improve strength and shock resistance. Blunting of the threads on both receptacle and plug coupling nut eliminates cross threading.

Elongated mounting holes permit the Series III Connector to intermount with various existing Mil-spec flange mounted receptacles, giving it a design replacement advantage.

Wall mount receptacle, jam nut receptacle and straight self-locking RFI plug are offered in 9 shell sizes and 54 insert arrangements utilizing M39029 contacts in sizes 22D, 20, 16, 12, 10 power and 8 twinax.

These connectors are available in wide range of shell materials and finishes. Aluminum shells are offered in electroless nickel and olive drab cadmium. Other finishes such as anodic and zinc cobalt are available upon request to commercial callouts only. In addition, we offer stainless steel shells (both passivated and electro-deposited nickel plated) with firewall inserts, and for highly corrosive environments, nickel-aluminum-bronze shells with standard environment-resisting inserts (commercial callouts only).

**MIL-STD-1560 Insert Arrangements** – Series III connectors use insert patterns and contacts common to Series I, making for an easy transition from bayonet to triple-lead, acme-thread, self-locking coupling.

**Metal-to-Metal Bottoming** – This feature precludes relative shell-to-shell motion, which may result in ordinary connector wear and moisture entrapment.

**Lockwiring Eliminated** – Self-locking quick coupling plug eliminates the need for lockwiring.

**Firewall Capability** - Stainless steel shells in both K and S firewall classes are offered.

**Universal I/R Tool** – A single, expendable plastic tool is used for both insertion and removal of contacts.

**Scoop-Proof Design** – Recessed pins in elongated shells minimize the possibility for contact damage. In a blind mating application, mating shells cannot “scoop” the pins, and cause a shorting or bending of contacts.

**Closed-Entry Socket Insert** – Hard dielectric socket face has lead-in chamfers for positive alignment of pins (even partially bent within pre-established limits) with sockets.

**Interfacial Pin Insert Seal** – Raised moisture barriers around each pin, which mate into lead-in chamfers of hard face socket insert, provide individual contact sealing. Interfacial seal is never touched by service tools.

**Elastomer Wire Sealing Grommet** – Sealing over a wide range of wire diameters is assured by a triple wire seal in each cavity at the rear of the connector.

**Superior Contact Stability** – Rear release crimp contact system features a stamped beryllium-copper retaining clip captivated by molded-in shoulders of each contact cavity in the insulator. A rear-inserted M81969 plastic tool expands the tines beyond the shoulder, releasing the contact.

**Metric Accessory Thread** – Metric thread results in additional wall thickness giving greater strength and shock resistance.

**Twinax Contacts** – Aero Electric is Qualified to make and supply M39029/90-529 and M39029/91-530 size 8 Twinax contacts used in 38999 III connectors. Please consult factory even when needing to buy just the contacts.





**MIL-DTL-38999**  
**Performance Specifications**  
**Series III**



## Performance Specifications

### Operating Temperature Range

Classes F, K, S, RN\*, BZ\*: -65°C to +200°C (-85°F to +392°F)  
 Classes W, T, Z, & BN\*: -65°C to +175°C (-85°F to +347°F)

### Material and Finish Data (Class)

- F – aluminum shell, electroless nickel finish
- K – stainless steel shell, passivated, firewall
- S – stainless steel shell, electrodeposited nickel, firewall
- T\* - aluminum shell, nickel flouorocarbon polymer finish
- W- aluminum shell, olive drab cadmium over nickel base
- Z - aluminum shell, zinc nickel finish(RoHS)
- BN\* -aluminum shell, black nickel finish(RoHS)
- BZ\* – aluminum nickel bronze shell, std insert
- RN\* - aluminum shell, electroless nickel finish (RoHS)

### Corrosion Resistance

Military Classes K, W, Z, and S withstand 500-hour salt spray. Military Class F withstands 48-hour salt spray. Commercial RoHS compliant Class RN\* withstands 48-hour salt spray. Commercial RoHS compliant Classes BZ\* and T\* withstand 500-hour salt spray. Commercial RoHS compliant Class BN\* withstands 400-hour salt spray.

### Durability

Minimum of 500 mating cycles.

### Fluid Resistance

Connectors resist specified immersions in MIL-PRF-7808, MIL-PRF-23699, MIL-PRF-5606, M2-V Chevron oil, Coolanol 25, MIL-DTL-83133 (JP-8), MIL-DTL-5624 (JP-4, JP-5), SAE-AMS1424 Type I, and other solvents and cleaning agents.

### Shielding Effectiveness

RFI and EMI attenuation at the specified frequencies meet the requirements of MIL-DTL-38999.

- RFI shielding effectiveness of mated connectors with RFI backshells is measured in a triaxial radio frequency leakage fixture.
- EMI shielding effectiveness is measured at the interface of mated connectors and tested by the mode-stirred technique specified in method 3008 of MIL-STD-1344.

### Voltage Rating

Service Rating	Suggested Operating Voltage		Test Voltage	Test Voltage	Test Voltage	Test Voltage
	(Sea Level)		Sea Level	50,000 Ft.	70,000 Ft.	100,000 Ft.
	AC (RMS)	DC	V RMS	V RMS	V RMS	V RMS
M	400	550	1300	550	350	200
N	300	450	1000	400	260	200
I	600	850	1800	600	400	200
II	900	1250	2300	800	500	200

**Note:** The establishment of electrical safety factors is left entirely to the designer, as he/she is in the best position to

### Environmental Seal

Wired, mated connectors with specified accessories attached, shall meet the altitude-immersion test specified in MIL-DTL-38999.

### Shell-to-Shell Conductivity

Maximum potential drop shall not exceed:

- Classes F and S = 1.0 millivolt.
- Class W & Z = 2.5 millivolts, Class K = 10.0 millivolts

### Shock and Vibration Requirements

Wired, mated connectors shall not be damaged, nor shall there be a current interruption longer than one microsecond when subjected to the following:

#### Shock

Pulse of approximate half sine wave of 300 G ± 15 percent magnitude with duration of 3 ± 1 milliseconds applied in three axes.

#### High Impact Shock

When mounted as specified in MIL-S-901, grade A, a drop of a 400 lb. Hammer from 1 foot, 3 feet and 5 feet applied to connector in three axes, totaling nine impacts.

#### Vibration

Wired and mated connectors withstand the following vibration levels:

- Sine vibration where connector samples with simulated accessory load are subjected to simple harmonic motion from 10 to 2,000 Hz in three mutually perpendicular axes, in 20 minute sweeps, for 12 hours in each axis at velocity of 254 mm/sec from 10-50 Hz, displacement of 1.5 mm from 50-140Hz and acceleration of 60G from 140-2,000Hz.
- Random Vibration per MIL-STD-1344, method 2005, test condition V at ambient temperature and test condition VI, Letter “J” at elevated temperature.

\* Not on QPL, can be supplied to Aero-Electric part number only.

know exactly what peak voltages, switching currents, transients, etc., can be expected in a particular circuit.



**Military and Aero-Electric Part Number Development**

<b>Mil. Prefix</b>	<b>D38999/</b>	<b>20</b>	<b>W</b>	<b>C</b>	<b>35</b>	<b>P</b>	<b>N</b>	
<b>Aero Prefix</b>	<b>AE3</b>	<b>20</b>	<b>W</b>	<b>C</b>	<b>35</b>	<b>P</b>	<b>N</b>	<b>-340</b>
<b>Shell Type (Specification Sheet Number)</b>								
20 = Wall mount receptacle								
24 = Jam nut receptacle								
26 = Self-locking, RFI grounding plug								
<b>Class (Material &amp; Finish)</b>								
F = Aluminum shell, electroless nickel finish								
W = Aluminum shell, olive drab cadmium over electroless nickel base								
T = Aluminum shell, nickel flouorocarbon polymer finish (consult factory for availability)								
Z = Aluminum shell, zinc nickel finish (black)								
K = Stainless steel shell, passivated, with firewall insert								
S = Stainless steel shell, electrodeposited nickel, with firewall insert								
BN* = Aluminum shell, black nickel finish, (RoHS), (Aero p/n/ only)								
BZ* = Aluminum nickel bronze shell with standard insert (Aero p/n only)								
ZC* = Aluminum shell, zinc cobalt plating, (RoHS), (Aero p/n only)(black)								
L* = Stainless steel shell, electrodeposited nickel, non-firewall/standard insert (Aero p/n only)								
<b>Shell Size</b>								
A, B, C, D, E, F, G, H or J								
<b>Insert Arrangement</b>								
See pages 60 thru 62								
<b>Contact Style</b>								
P = Pin								
S = Socket								
A = Pin connector less pins (with intent to use non-std pin contacts)								
B = Socket connector less sockets (with intent to use non-std socket contacts)								
<b>Polarization (Keying)</b>								
N = Normal (Included in part number)								
A, B, C, D, or E								
<b>Modification (applies to Aero part numbers only)</b>								
01 = Less contacts (is not marked on the part)								
340 = Connector kitted with M85049/15-XXX								
341 = Connector kitted with M85049/38-XXX straight clamp								
342 = Connector kitted with M85049/39-XXX right angle clamp								
Consult factory for other modifications								

38999 S III

\* Not on QPL, can be supplied to Aero-Electric part number only.

**Note 1:** Each connector is furnished with contacts unless ordered less contacts (L/C) as follows: One spare contact for inserts requiring 2 through 26 of each contact and two spares for inserts with 27 or more contacts, and a minimum of one sealing plug up to 10% of the number contacts. Spare Coax and Twinax contacts are not supplied. One insertion/extraction tool for each contact size is also included.

**Note 2:** Proper part number marking has no “0” in front of single digit layout. Example: J D38999/20WB5SN. “N” for normal is included. In addition, J or JAN must be marked immediately in front of MIL part number.

**D38999/20**  
**Wall Mount Receptacle**  
**AE320**



**Triple Start Threaded Coupling, Crimp Removable, Rear Release, Scoop-Proof**

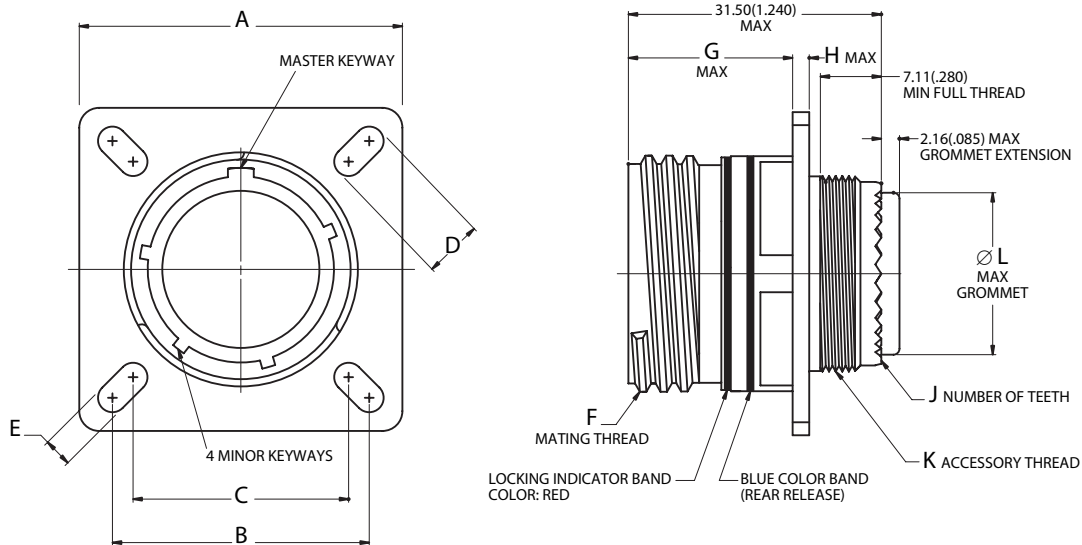

38999 S III

Page 46	Completed Part Number
Page 52	Contacts, Sealing Plugs and Tools
Pages 60–62	Insert Arrangements
Page 45	Performance Specifications
Pages 58, 59	Insert Availability and Contact Information
Page 50	Polarization

**Note 1:** “K” Accessory Thread for AE320 is same as AE326 (“D” Accessory Thread) on page 49.

**Note 2:** “F” Mating Thread for AE320 is same as AE326 (“E” Mating Thread) on page 49 except it is Class 2A.

**Note 3:** Maximum Grommet Extension for insert layouts incorporating size 8 and 10 contacts = **5.95(.234)**.

Shell Size	A		B		C		D		E		G		H		J	Ø L	
	±.012	±.30	(TP)		(TP)		±.008	±.20	±.008	±.20	Maximum		Maximum		No. of Teeth	Maximum	
	inch	mm	inch	mm	inch	mm	inch	mm	inch	mm	inch	mm	inch	mm		inch	mm
A	.937	23.80	.719	18.26	.594	15.09	.216	5.49	.128	3.25	.820	20.83	.098	2.50	12	.299	7.59
B	1.031	26.20	.812	20.62	.719	18.26	.194	4.93	.128	3.25	.820	20.83	.098	2.50	16	.427	10.85
C	1.126	28.60	.906	23.01	.812	20.62	.194	4.93	.128	3.25	.820	20.83	.098	2.50	20	.541	13.74
D	1.220	31.00	.969	24.61	.906	23.01	.173	4.39	.128	3.25	.820	20.83	.098	2.50	24	.666	16.92
E	1.311	33.30	1.062	26.97	.969	24.61	.194	4.93	.128	3.25	.820	20.83	.098	2.50	28	.791	20.09
F	1.437	36.50	1.156	29.36	1.062	26.97	.194	4.93	.128	3.25	.820	20.83	.098	2.50	32	.897	22.78
G	1.563	39.70	1.250	31.75	1.156	29.36	.194	4.93	.128	3.25	.790	20.07	.126	3.20	36	1.022	25.96
H	1.689	42.90	1.375	34.93	1.250	31.75	.242	6.15	.154	3.91	.790	20.07	.126	3.20	40	1.147	29.13
J	1.811	46.00	1.500	38.10	1.375	34.93	.242	6.15	.154	3.91	.790	20.07	.126	3.20	44	1.272	32.31

**Triple Start Threaded Coupling, Crimp Removable, Rear Release, Scoop-Proof**

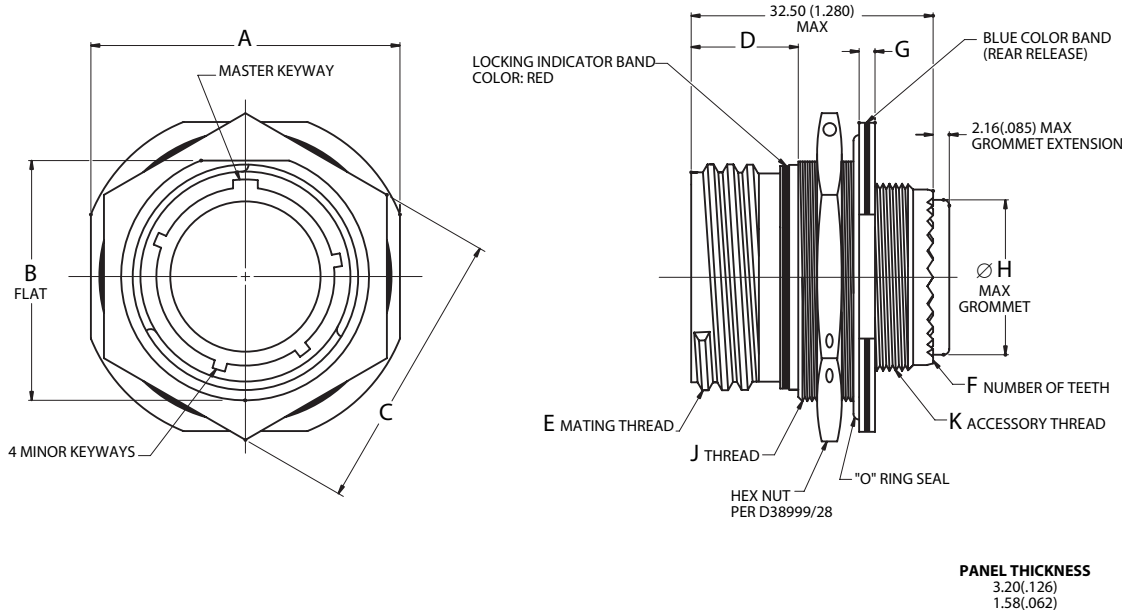

38999 S III

Page 46	Completed Part Number
Page 52	Contacts, Sealing Plugs and Tools
Pages 60–62	Insert Arrangements
Page 45	Performance Specifications
Pages 58, 59	Insert Availability and Contact Information
Page 50	Polarization

**Note 1:** “K” Accessory Thread for AE324 is same as AE326 (“D” Accessory Thread) on page 49.

**Note 2:** “E” Mating Thread for AE324 is same as AE326 (“E” Mating Thread) on page 49 except it is Class 2A.

**Note 3:** Maximum Grommet Extension for insert layouts incorporating size 8 and 10 contacts = **5.95(.234)**.

Shell Size	A		B		C		D		F No. of Teeth	G		Ø H		J Jam Nut Thread
	inch	mm	inch	mm	inch	mm	inch	mm		inch	mm	inch	mm	
A	1.063	27.00	.651	16.53	.945/1.859	24.00/21.82	.555	14.10	12	.087	2.20	.299	7.59	M17x1-6g
B	1.252	31.80	.751	19.07	1.063/1.984	27.00/24.99	.555	14.10	16	.087	2.20	.427	10.85	M20x1-6g
C	1.374	34.90	.938	23.82	1.260/1.172	32.00/29.77	.555	14.10	20	.087	2.20	.541	13.74	M25x1-6g
D	1.500	38.10	1.062	26.97	1.417/1.296	36.00/32.91	.555	14.10	24	.087	2.20	.666	16.92	M28x1-6g
E	1.626	41.30	1.187	30.15	1.457/1.422	37.00/36.12	.555	14.10	28	.087	2.20	.791	20.09	M32x1-6g
F	1.811	46.00	1.312	33.32	1.614/1.546	41.00/39.26	.555	14.10	32	.118	3.00	.897	22.78	M35x1-6g
G	1.937	49.20	1.437	36.50	1.811/1.672	46.00/42.47	.555	14.10	36	.118	3.00	1.022	25.96	M38x1-6g
H	2.063	52.40	1.562	39.67	1.969/1.796	50.00/45.61	.555	14.10	40	.118	3.00	1.147	29.13	M41x1-6g
J	2.189	55.60	1.687	42.85	2.017/1.939	51.23/49.25	.555	14.10	44	.118	3.00	1.272	32.31	M44x1-6g

**D38999/26**  
**Self-Locking, RFI Grounding Plug**  
**AE326**



**Triple Start Threaded Coupling, Crimp Removable, Rear Release, Scoop-Proof**

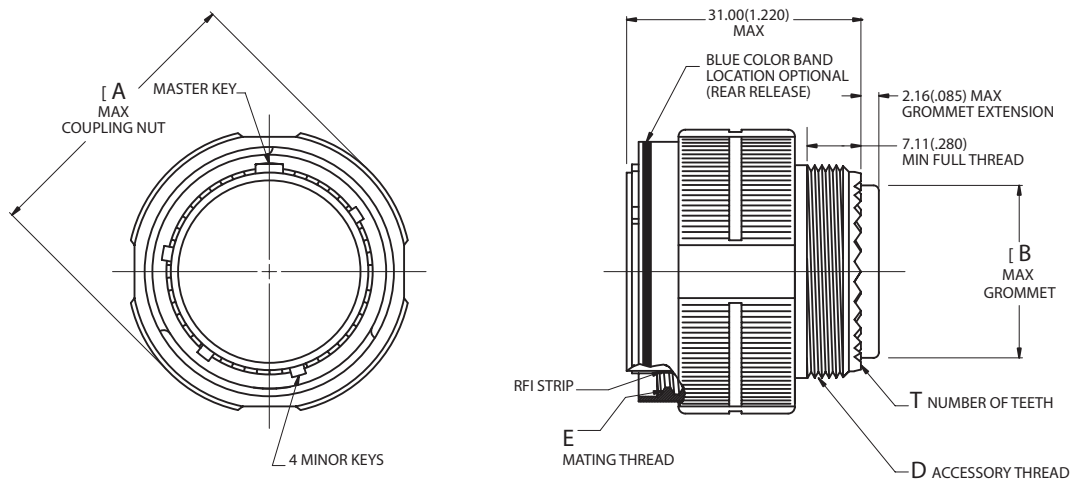

38999 S III

Page 46	Completed Part Number
Page 52	Contacts, Sealing Plugs and Tools
Pages 60–62	Insert Arrangements
Page 45	Performance Specifications
Pages 58, 59	Insert Availability and Contact Information
Page 50	Polarization

**Note :** Maximum Grommet Extension for insert layouts incorporating size 8 and 10 contacts = **5.95(.234)**.

Shell Size	Ø A		Ø B		D	E	T
	Maximum		Maximum		Accessory Thread Metric	Mating Thread Class 2B	No. of Teeth
	inch	mm	inch	mm			
A	.858	21.80	.299	7.59	M12x1.0-6g 0.100R	.6250-0.1P-0.3L	12
B	.984	25.00	.427	10.85	M15x1.0-6g 0.100R	.7500-0.1P-0.3L	16
C	1.157	29.40	.541	13.74	M18x1.0-6g 0.100R	.8750-0.1P-0.3L	20
D	1.280	32.50	.666	16.92	M22x1.0-6g 0.100R	1.0000-0.1P-0.3L	24
E	1.406	35.70	.791	20.09	M25x1.0-6g 0.100R	1.1875-0.1P-0.3L	28
F	1.516	38.50	.897	22.78	M28x1.0-6g 0.100R	1.2500-0.1P-0.3L	32
G	1.642	41.70	1.022	25.96	M31x1.0-6g 0.100R	1.3750-0.1P-0.3L	36
H	1.768	44.90	1.147	29.13	M34x1.0-6g 0.100R	1.5000-0.1P-0.3L	40
J	1.890	48.00	1.272	32.31	M37x1.0-6g 0.100R	1.6250-0.1P-0.3L	44

### Keying Positions

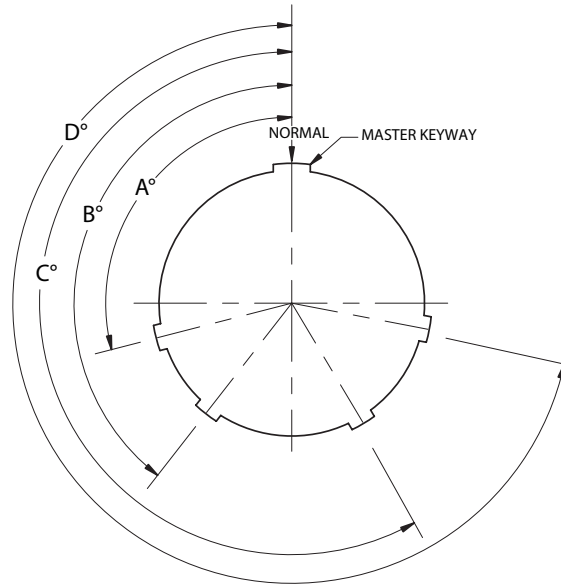

38999 S III

**Notes:**

1. Mating face of receptacle shown (plug is opposite).
2. All minor keyways (keys) are rotated to provide shell polarization while master keyway (key) remains fixed as shown.
3. The angles for a given connector are the same whether it contains pin or socket inserts.
4. Insert arrangement does not rotate relative to the master keyway (key).

Shell Size	Key/Keyway	Key/Keyway Positions			
	Identification Letter	BSC			
		A°	B°	C°	D°
A (9)	N	105	140	215	265
	A	102	132	248	320
	B	80	118	230	312
	C	35	140	205	275
	D	64	155	234	304
B (11) C (13) D (15)	E	91	131	197	240
	N	95	141	208	236
	A	113	156	182	292
	B	90	145	195	252
	C	53	156	220	255
E (17) F (19) G (21) H (23) J (25)	D	119	146	176	298
	E	51	141	184	242
	N	80	142	196	293
	A	135	170	200	310
	B	49	169	200	244
	C	66	140	200	257
	D	62	145	180	280
	E	79	153	197	272

# MIL-DTL-38999 Series III Flange and Jam Nut Receptacle Panel Cutouts



## Panel Cutouts

FLANGE MOUNT

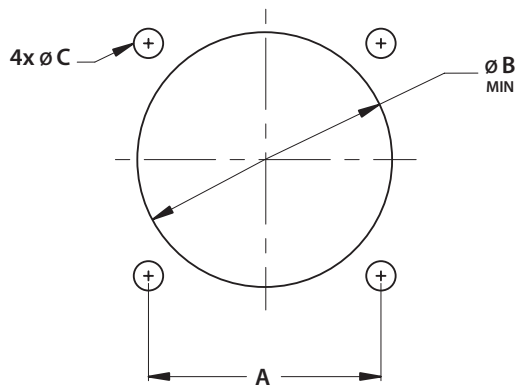

JAM NUT MOUNT

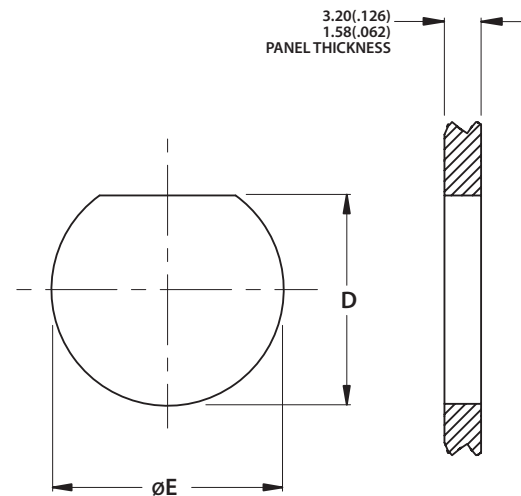

**Note:** Diameter B cutout dimensions are listed separately for back and front of panel mounting.

Shell Size	A		Ø B		Ø B		Ø C		D		Ø E	
	(TP)		For Back Mounting Minimum		For Front Mounting Minimum		±.005	±.13	+ .000*	+ .00*	+ .010	+ .25
	inch	mm	inch	mm	inch	mm	inch	mm	inch	mm	inch	mm
A (9)	.719	18.26	.656	16.66	.516	13.11	.128	3.25	.657*	16.70*	.700	17.78
B (11)	.812	20.62	.796	20.22	.625	15.88	.128	3.25	.771	19.59	.825	20.96
C (13)	.906	23.01	.922	23.42	.750	19.05	.128	3.25	.955	24.26	1.010	25.65
D (15)	.969	24.61	1.047	26.59	.906	23.01	.128	3.25	1.085	27.56	1.135	28.83
E (17)	1.062	26.97	1.219	30.96	1.016	25.81	.128	3.25	1.210	30.73	1.260	32.01
F (19)	1.156	29.36	1.297	32.94	1.141	28.98	.128	3.25	1.335	33.91	1.385	35.18
G (21)	1.250	31.75	1.422	36.12	1.266	32.16	.128	3.25	1.460	37.08	1.510	38.35
H (23)	1.375	34.93	1.547	39.29	1.375	34.93	.154	3.91	1.585	40.26	1.635	41.53
J (25)	1.500	38.10	1.672	42.47	1.484	37.69	.154	3.91	1.710	43.43	1.760	44.70

\* Tolerance ± .10mm (±.004")



## Dummy Stowage Receptacle Part Number Configuration

<b>MIL. Prefix</b>	<b>D38999/</b>	<b>22</b>	<b>C</b>	<b>W</b>
<b>Aero Prefix</b>	<b>AE3</b>	<b>22</b>	<b>C</b>	<b>W</b>
<b>Shell Type</b>				
22 = receptacle, dummy stowage, threaded				
<b>Shell Size**</b>				
A, B, C, D, E, F, G, H or J				
<b>Material Finish</b>				
W = Aluminum Shell, Olive Drab Cadmium Finish				
F = Aluminum, Electroless Nickel Finish				
K = Stainless Steel, Passivated				
S = Stainless Steel, Electrodeposited Nickel				
BN* = Aluminum Shell, Black Nickel Finish (Aero p/n only)				

\* Not on QPL, can be supplied to Aero-Electric part number only.

\*\* Shell size code A is for use with plugs with mating key polarizations "C", "E" or "N".  
 Shell size code AA is for use with plugs with mating key polarizations "A", "B" or "D".

38999 S III

## Protective Metal Caps Part Number Configuration

<b>MIL. Prefix</b>	<b>D38999/</b>	<b>32</b>	<b>W</b>	<b>11</b>	<b>R</b>
<b>Aero Prefix</b>	<b>AE3</b>	<b>32</b>	<b>W-</b>	<b>11</b>	<b>R</b>
<b>Shell Type</b>					
32 = cover, protective, plug					
33 = cover, protective, receptacle					
<b>Material Finish</b>					
W = Aluminum Shell, Olive Drab Cadmium Finish					
F = Aluminum, Electroless Nickel Finish					
K = Stainless Steel, Passivated					
S = Stainless Steel, Electrodeposited Nickel					
BN* = Aluminum Shell, Black Nickel Finish (Aero p/n only)					
<b>Shell Size</b>					
9,11,13, 15, 17, 19, 21, 23, 25					
<b>Style</b>					
R = Wire Rope Assembly					
N = Wire Rope/Ring Assembly					

\* Not on QPL, can be supplied to Aero-Electric part number only.



**D38999/22**  
**Dummy Stowage Receptacle**  
**AE322**



**AE322 Threaded Dummy Stowage Receptacle**

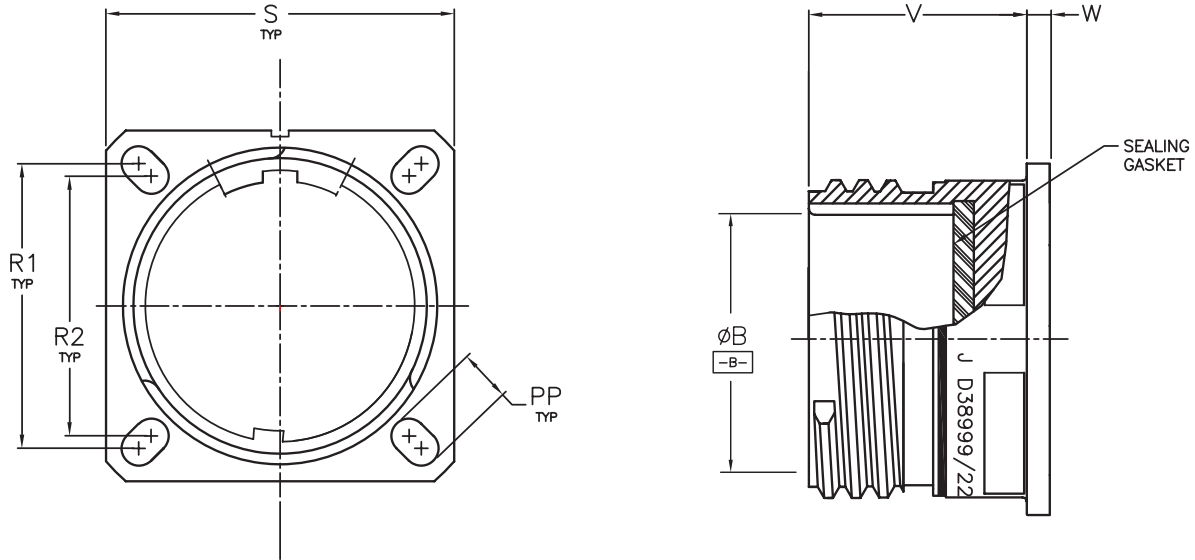

38999 S III

SHELL SIZE	SHELL SIZE CODE	Ø B		PP		R1		R2		S		V		W	
		MM	INCH	MM ±.20	INCH ±.008	MM	INCH	MM	INCH	MM ±.3	INCH ±.012	MM ±.00 -.13	INCH ±.000 -.005	MM ±.3	INCH ±.012
9	A	12.63 12.47	.497 .491	5.49	.216	18.26	.719	15.09	.594	23.8	.937	20.83	.820	2.5	.098
11	B	15.88 15.73	.625 .619	4.93	.194	20.62	.812	18.26	.719	26.2	1.031	20.83	.820	2.5	.098
13	C	19.63 19.49	.773 .767	4.93	.194	23.01	.906	20.62	.812	28.6	1.126	20.83	.820	2.5	.098
15	D	22.84 22.69	.899 .893	4.39	.173	24.61	.969	23.01	.906	31.0	1.220	20.83	.820	2.5	.098
17	E	25.99 25.84	1.023 1.017	4.93	.194	26.97	1.062	24.61	.969	33.3	1.311	20.83	.820	2.5	.098
19	F	28.63 28.48	1.127 1.121	4.93	.194	29.36	1.156	26.97	1.062	36.5	1.437	20.83	.820	2.5	.098
21	G	31.83 31.68	1.253 1.247	4.93	.194	31.75	1.250	29.36	1.156	39.7	1.563	20.07	.790	3.2	.126
23	H	35.03 34.88	1.379 1.373	6.15	.242	34.93	1.375	31.75	1.250	42.9	1.689	20.07	.790	3.2	.126
25	J	38.18 38.03	1.503 1.497	6.15	.242	38.10	1.500	34.93	1.375	46.0	1.811	20.07	.790	3.2	.126

**Protective Cover Plug**

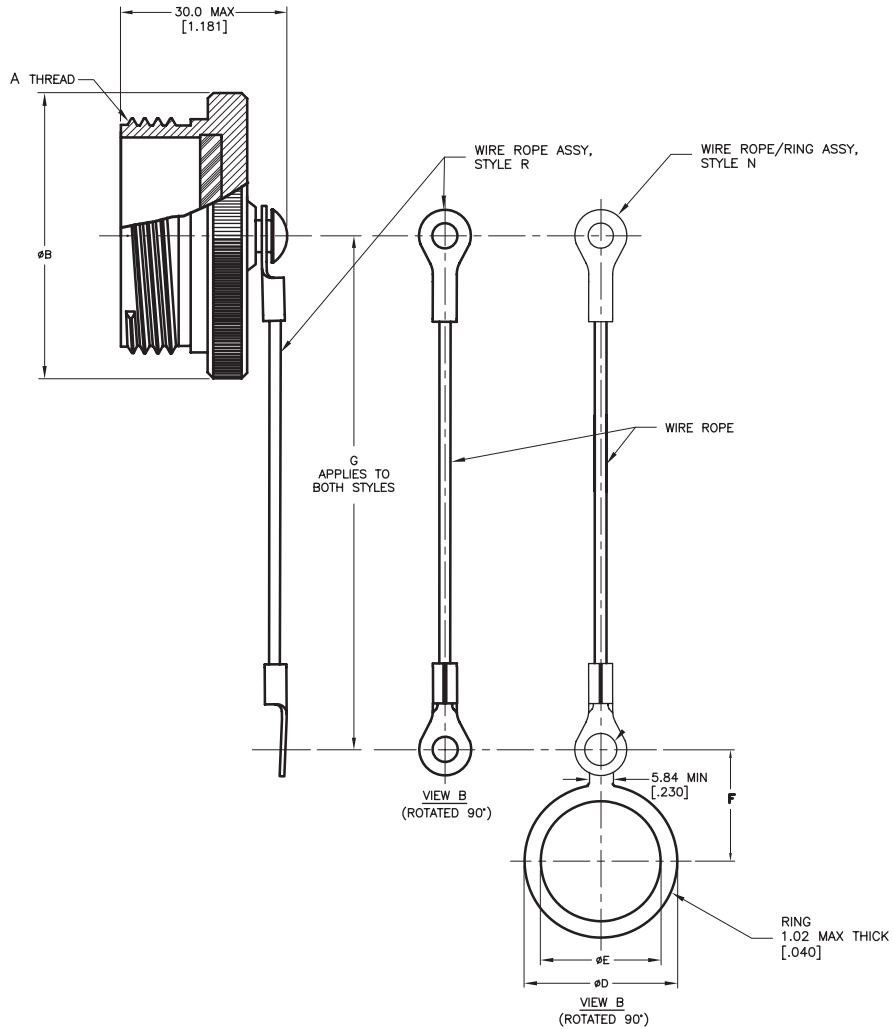

SHELL SIZE	A THREAD CLASS 2A TRIPLE START	Ø B MAX		Ø D MAX		Ø E MAX		G	
		INCH	MM	INCH	MM	INCH	MM	INCH +.512 -.276	MM +13.0 -7.0
9	.6250-0.1P-0.3L	.906	23.0	.945	24.0	.512	13.0	5.000	127.00
11	.7500-0.1P-.03L	1.024	26.0	1.063	27.0	.709	18.0	5.000	127.00
13	.8750-0.1P-.03L	1.221	31.0	1.181	30.0	.787	20.0	5.000	127.00
15	1.0000-0.1P-.03L	1.299	33.0	1.221	31.0	.906	23.0	5.000	127.00
17	1.1875-0.1P-.03L	1.457	37.0	1.457	37.0	1.024	26.0	5.000	127.00
19	1.2500-0.1P-.03L	1.575	40.0	1.575	40.0	1.142	29.0	5.000	127.00
21	1.3750-0.1P-.03L	1.732	44.0	1.732	44.0	1.260	32.0	5.000	127.00
23	1.5000-0.1P-.03L	1.811	46.0	1.811	46.0	1.339	34.0	5.000	127.00
25	1.6250-0.1P-.03L	1.969	50.0	1.929	49.0	1.535	39.0	5.000	127.00

38999 S III

**D38999/33**  
**Protective Cover, Receptacle**  
**AE333**



**Protective Cover Receptacle**

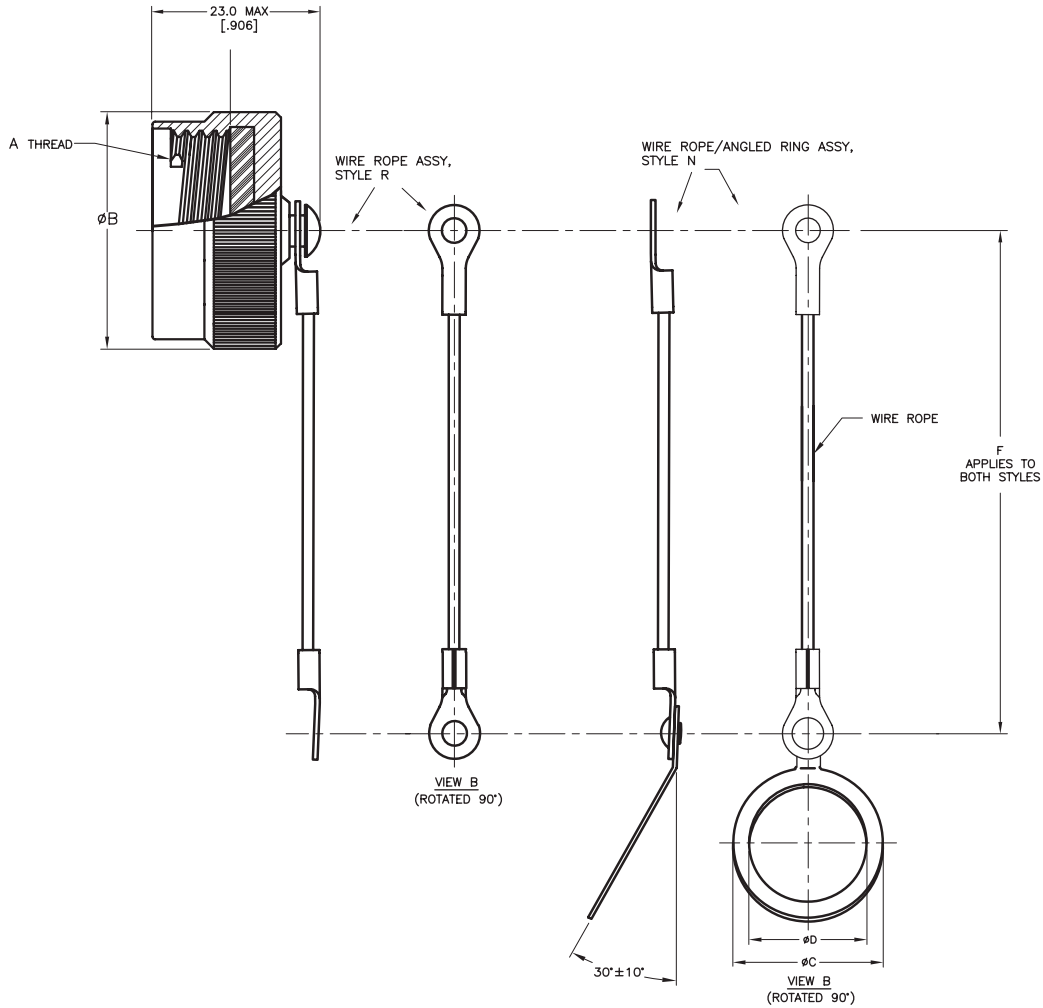

38999 S III

SHELL SIZE	A THREAD CLASS 2B TRIPLE START	Ø B MAX		Ø C MAX		Ø D MIN		F	
		INCH	MM	INCH	MM	INCH	MM	INCH	MM
9	.6250-0.1P-0.3L	.906	23.0	1.063	27.0	.695	17.64	5.000	127.00
11	.7500-0.1P-0.3L	1.102	28.0	1.260	32.0	.865	21.97	5.000	127.00
133	.8750-0.1P-0.3L	1.221	31.0	1.457	37.0	.989	25.12	5.000	127.00
15	1.0000-0.1P-0.3L	1.260	32.0	1.575	40.0	1.178	29.92	5.000	127.00
17	1.1875-0.1P-0.3L	1.457	37.0	1.732	44.0	1.260	32.00	5.000	127.00
19	1.2500-0.1P-0.3L	1.535	39.0	1.811	46.0	1.428	36.27	5.000	127.00
21	1.3750-0.1P-0.3L	1.654	42.0	1.929	49.0	1.506	38.25	5.000	127.00
23	1.5000-0.1P-0.3L	1.772	45.0	2.126	54.0	1.678	42.62	5.000	127.00
25	1.6250-0.1P-0.3L	1.929	49.0	2.205	56.0	1.750	44.45	5.000	127.00



**MIL-DTL-38999**  
**Contacts, Tools and Seal Plugs**  
**Series III**

**Contacts, Plastic Insertion/Removal Tools and Seal Plugs**

Contact Size	Application	Pin Contacts	Socket Contacts	Seal Plugs	Insertion/Removal Tools
	Type	Military No.	Military No.	Military No.	Plastic Military No.
22D	Power/Signal	M39029/58-360	M39029/56-348	MS27488-22-1	M81969/14-01
20	Power/Signal	M39029/58-363	M39029/56-351	MS27488-20-1	M81969/14-10
16	Power/Signal	M39029/58-364	M39029/56-352	MS27488-16-1	M81969/14-03
12	Power/Signal	M39029/58-365	M39029/56-353	MS27488-12-1	M81969/14-04
12 Coax	Coax	M39029/28-211	M39029/75-416		
12 Coax	Coax	M39029/102-558	M39029/103-559		
10 (Power)	Power	M39029/58-528	M39029/56-527	M85049/81-10***	M81969/14-05
8 Coax	Coax	M39029/60-367	M39029/59-366	MS27488-8-1	M81969/14-06
8 Twinax****	Twinax	M39029/90-529	M39029/91-530	MS27488-8-1	M81969/14-12

**Crimping and Metal Insertion/Extraction Tools**

Contact Size/Type	Crimp Tool	Positioner	Positioner	Insertion Tool	Extraction Tool
		For Pin Contacts	For Socket Contacts	Metal	Metal
	Military No.	Military No.	Military No.	Military No.	Military No.
22D	M22520/2-01	M22520/2-09	M22520/2-07	M81969/8-01	M81969/8-02
20	M22520/1-01	M22520/1-04	M22520/1-04	M81969/8-05	M81969/8-06
	M22520/2-01	M22520/2-10	M22520/2-10		
16	M22520/1-01	M22520/1-04	M22520/1-04	M81969/8-07	M81969/8-08
12	M22520/1-01	M22520/1-04	M22520/1-04	M81969/8-09	M81969/8-10
12 Coax Inner	M22520/2-01	M22520/2-34	M22520/2-34		
12 Coax Outer	M22520/31-01	M22520/31-02	M22520/31-02		
10 ( Power)	—	—	—	M81969/8-11	M81969/8-12
8 Coax Inner	M22520/2-01	M22520/2-31	M22520/2-31	M81969/8-13**	M81969/8-14
8 Coax Outer	M22520/5-01	M22520/5-05 Die Closure B	M22520/5-05 Die Closure B		
8 Twinax Center	M22520/2-01	M22520/2-37	M22520/2-37	—	—
8 Twinax Outer & Intermediate	M22520/5-01	M22520/5-200	M22520/5-200		

38999 S III

**Contact and Wire Data**

Contact Size	Test Current*	Voltage*	Crimp Well Data			Wire Range		Finished Wire Ø Range			
	DC Test	Max. Drop	Well Dia.	Minimum Well Dept				Minimum		Maximum	
	Amps	Millivolts	inch	inch	mm	AWG	mm <sup>2</sup>	inch	mm	inch	mm
22D	5.0	73	.0345 ±.0010	.141	3.58	28-22	.08-.33	.030	.76	.054	1.37
20	7.5	55	.047 ±.001	.209	5.31	24-20	.20-.52	.040	1.02	.083	2.11
16	13.0	49	.067 ±.001	.209	5.31	20-16	.52-1.31	.065	1.65	.109	2.77
12	23.0	42	.100 ±.002	.209	5.31	14-12	2.08-3.31	.097	2.46	.142	3.61
10	33.0	33	.137 ±.003	.355	9.02	12-10†	3.31-5.26	.135	3.42	.162	4.12

† MS3348 bushing required with 12 gauge wire.

\* When tested with silver-plated wire.

\*\* Insertion tool is not required.

\*\*\* Dummy contact, used in lieu of unwired contact and seal plug.

\*\*\*\* Aero Electric is Qualified for Twinax contacts, consult factory for a quote.

**Note:** Size 8 coax contacts are used with M17/095-RG180 cable, while size 8 Twinax contacts are used with M17/176-00002 cable.

**Note 2:** Size 8 Power contacts available with various crimp wells – 5265-244-08xx and 5065-246-08xx – please consult factory for sales drawing that includes various tooling needed.

## Contact Installation Instructions

### Crimping Contacts

1. Select the appropriate crimp tool and ensure that the proper crimp head positioner is used.
2. Cycle the tool to be sure the indentors are open.
3. Determine the correct selector setting for the wire size from the data plate on the positioner (turret head assembly) and set the selector knob on the crimp tool to match.
4. Place the contact, mating end first, into the tool.
5. Insert the stripped wire into the hollow end of the contact. Be sure the wire is inserted as far as it will go.
6. Close the tool completely to crimp. Unless the tool is closed completely, the tool will not release the contact.
7. Remove the crimped contact from the tool. Check the inspection hole to verify that the wire is fully inserted.

### Insertion of Contacts

1. Before inserting the contacts, unscrew the accessories (clamps, backshells or adapters) from rear of plug or receptacle. Slide the hardware over the wire bundle in the proper order for reassembly after all the contacts are inserted.
2. To assist insertion of contacts, lubricate insulator (grommet) cavities with isopropyl alcohol. Alcohol will evaporate and will not leave a conductive film. **Caution: Never use any lubricant other than isopropyl alcohol.**

3. Place the correct insertion tool on the contact so that the wire runs along the groove in the tool. (Tool tip will butt against the shoulder.) Hold the plug or receptacle body firmly.
4. Beginning with a center cavity, insert the contact into the insulator with a slow, even pressure until the contact snaps into position. Make sure the contact and tool are held perpendicular to the face of the insert during the contact installation or the grommet could be damaged.
- 4.1 If contacts are not inserted all the way prior to removing insertion tool, do not try to reinsert the insertion tool. Instead, remove the contact and try again; otherwise reinserting the insertion tool may damage the inside of the contact cavity.
5. Remove tool and check the face of the connector for proper contact installation. Proper installation may also be checked by pulling back lightly on the wire to make sure the contact is properly seated.

### Completion

After all the cavities have been filled, slide the hardware back into position on the connector and tighten.

### Extraction of Contacts (Rework)

1. Slide the hardware back over the wire bundle.
2. Select the appropriate tool. Place the wire into the extraction tool of the pin or socket.
3. Slowly slide the extraction tool down wire into the contact cavities until the tool tip bottoms against the contact shoulder, expanding the clip retaining tines. Hold the wire firmly in the tool and pull the wired contact and tool straight out of the rear of the insulator.

Size	Pin Contact	Socket Contact	Basic Crimp Tool	Pin Positioner	Socket Positioner	Insertion/Removal Tool
22D	M39029/58-360	M39029/56-348	M22520/2-01	M22520/2-09	M22520/07	M81969/14-01
20	M39029/58-363	M39029/56-351	M22520/1-01	M22520/1-04 Red	M22520/1-04 red	M81969/14-10
			M22520/2-01	M22520/2-10	M22520/2-10	
16	M39029/58-364	M39029/56-352	M22520/1-01	M22520/1-04 Blue	M22520/1-04 Blue	M81969/14-03
12	M39029/58-365	M39029/56-353	M22520/1-01	M22520/1-04 Yellow	M22520/1-04 Yellow	M81969/14-04
10	M39029/58-528	M39029/56-527	*	*	*	M81969/14-05

For Coax and Twinax contacts refer to instructions that are supplied with contacts.

\* Contact Daniels Manufacturing for crimp tool/positioner.



**MIL-DTL-38999 Series III**  
**Insert Availability and Contact Information**  
**per MIL-STD-1560**

**Insert Availability and Contact Information**

Insert Arrangement	Aero-Electric		Service	Total	Quantity of Contacts					
	Status			No. of	(by Size)					
Series III	QPL'd	Tooled	Rating	Contacts	22D	20	16	12	10	8
A35	Yes	Yes	M	6	6					
A98	Yes	Yes	I	3		3				
B2	Yes	Yes	I	2			2			
B4	Yes	Yes	I	4		4				
B5	Yes	Yes	I	5		5				
B35	Yes	Yes	M	13	13					
B98	Yes	Yes	I	6		6				
B99	Yes	Yes	I	7		7				
C4	Yes	Yes	I	4			4			
C8	Yes	Yes	I	8		8				
C35	Yes	Yes	M	22	22					
C98	Yes	Yes	I	10		10				
D5	Yes	Yes	II	5			5			
D15	Yes	Yes	I	15		14	1			
D18	Yes	Yes	I	18		18				
D19	Yes	Yes	I	19		19				
D35	Yes	Yes	M	37	37					
D97	Yes	Yes	I	12		8	4			
E6	Yes	Yes	I	6				6		
E8	Yes	Yes	II	8			8			
E26	Yes	Yes	I	26		26				
E35	Yes	Yes	M	55	55					
E99	Yes	Yes	I	23		21	2			
F11	Yes	Yes	II	11			11			
F28	Yes	Yes	I	28		26	2			
F30	Yes	Yes	I	30		29	1			
F32	Yes	Yes	I	32		32				
F35	Yes	Yes	M	66	66					

See next page for Shell Sizes G thru J layouts.

38999 S III

**MIL-DTL-38999 Series III**  
**Insert Availability and Contact Information**  
**per MIL-STD-1560**



**Insert Availability and Contact Information (continued)**

Insert Arrangement	Aero-Electric		Service	Total	Quantity of Contacts					
	Status			No. of	(by Size)					
Series III	QPL'd	Tooled	Rating	Contacts	22D	20	16	12	10	8
G11++	Yes	Yes	I	11				11		
G16	Yes	Yes	II	16			16			
G35	Yes	Yes	M	79	79					
G39	Yes	Yes	I	39		37	2			
G41	Yes	Yes	I	41		41				
G48**	N/A	Yes	I	4						4 (Power)
G75	Yes	Yes	Twinax	4						4 (Twinax)
H21	Yes	Yes	II	21			21			
H32	Yes	Yes	I	32		32				
H35	Yes	Yes	M	100	100					
H53	Yes	Yes	I	53		53				
H55	Yes	Yes	I	55		55				
J4	Yes	Yes	I	56		48	8			
J8	Yes	Yes	Twinax	8						8 (Twinax)
J11	Yes	Yes	N	11		2			9	
J19	Yes	Yes	I	19				19		
J20	Yes	Yes	N, Coax, Twinax	30		10	13	4 (Coax)		3 (Twinax)
J24	Yes	Yes	I	24			12	12		
J29	Yes	Yes	I	29			29			
J35	Yes	Yes	M	128	128					
J37	Yes	Yes	II	37			37			
J43	Yes	Yes	I	43		23	20			
J46***	Yes	Yes	I, Coax	46		40	4			2 (Coax)
J61	Yes	Yes	I	61		61				
J90	Yes	Yes	I, Twinax	46		40	4			2 (Twinax)

38999 S III

\*\* G48 layout is not to MIL-STD-1560. It is tooled and intended for comm'l use only.

\*\*\* Not approved for new design. Pictorial is shown on page 62.

++ G11 insert arrangement cannot be ordered with A or B suffix, as certifying agency does not want non-standard contacts used in these connectors.

**Note 1:** J20P uses 4 size 12 coax contacts as follows: 2 ea M39029/28-211 and 2 ea of M39029/102-558; J20S uses 4 size 12 coax contacts as follows: 2 ea M39029/75-416 and 2 ea of M39029/103-559.

**Note 2:** Layouts (G75, J8, J20, J46 and J90) that take twinax or coax contacts should not be used for firewall applications (Classes K & S) in Series III.

**Note 3:** H and J contact styles (in lieu of P & S) are meant for Composite (classes J & M) Series III only. Aluminum (classes F & W) and Firewall (classes K & S) are rated for 500 cycles regardless what contacts are used.

Insert Arrangements Views



A35,  
6 # 22D, M



A98,  
3 # 20, I

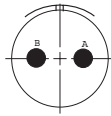

B2,  
2 # 16, I

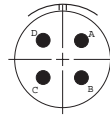

B4,  
4 # 20, I

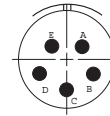

B5,  
5 # 20, I

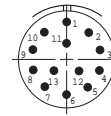

B35,  
13 # 22D, M

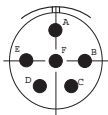

B98,  
6 # 20, I

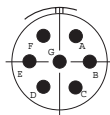

B99,  
7 # 20, I

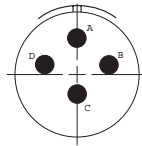

C4,  
4 # 16, I

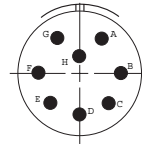

C8,  
8 # 20, I

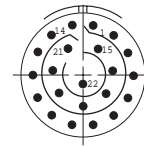

C35,  
22 # 22D, M

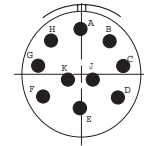

C98,  
10 # 20, I

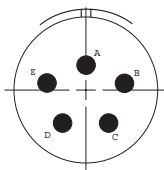

D5,  
5 # 16, II

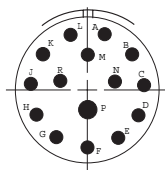

D15,  
1 # 16, 14 # 20, I

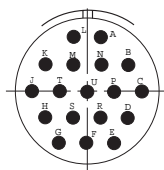

D18,  
18 # 20, I

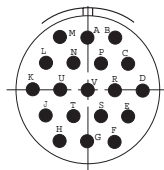

D19,  
19 # 20, I

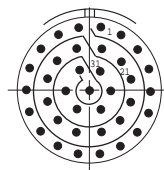

D35,  
37 # 22D, M

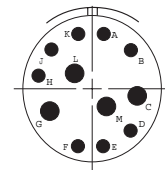

D97,  
4 # 16, 8 # 20, I

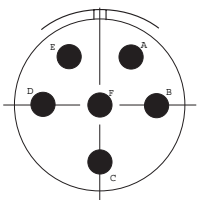

E6,  
6 # 12, I

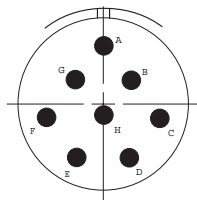

E8,  
8 # 16, II

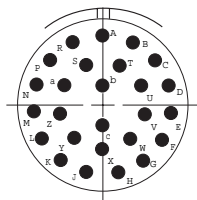

E26,  
26 # 20, I

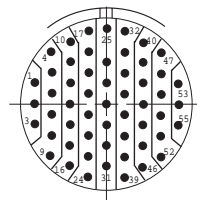

E35,  
55 # 22D, M

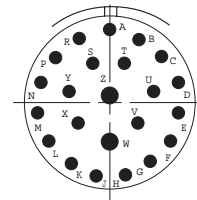

E99,  
2 # 16, 21 # 20, I

38999 S III



**MIL-STD-1560**  
**Insert Arrangements (Pin Front View)**  
**for MIL-DTL-38999 Series III Connectors**



**Insert Arrangements Views**

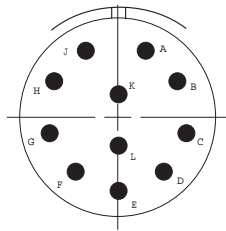

F11,  
11 # 16, II

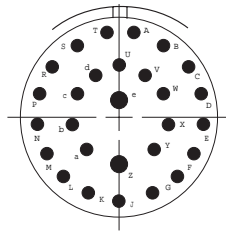

F28,  
2 # 16, 26 # 20, I

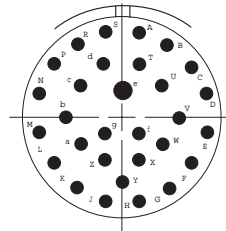

F30,  
1 # 16, 29 # 20, I

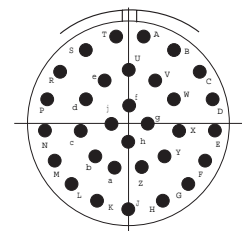

F32,  
32 # 20, I

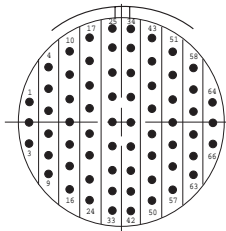

F35,  
66 # 22D, M

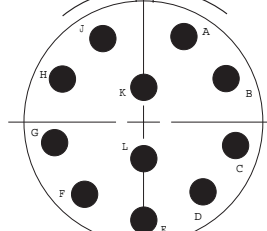

G11,  
11 # 12, I

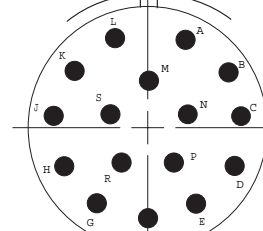

G16,  
16 # 16, II

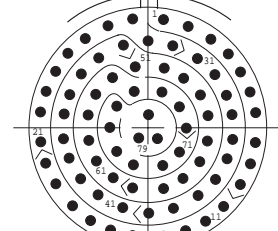

G35,  
79 # 22D, M

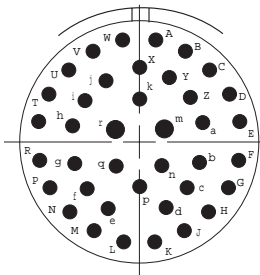

G39,  
2 # 16, 37 # 20, I

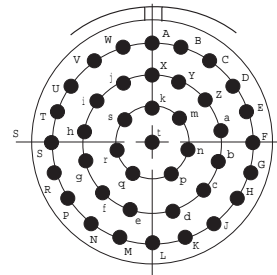

G41,  
41 # 20, I

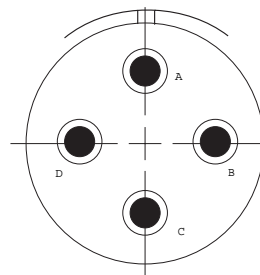

G48\*\*,  
4 # 8 Power, I

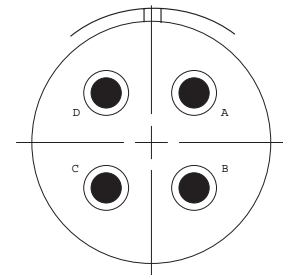

G75,  
4 # 8 Twinax, Twinax

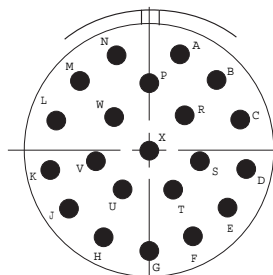

H21,  
21 # 16, II

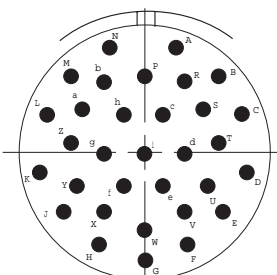

H32,  
32 # 20, I

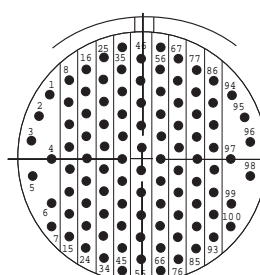

H35,  
100 # 22D, M

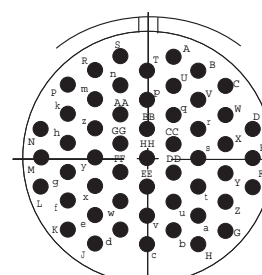

H53,  
53 # 20, I

\* Inactive for new design.

\*\* Not MIL-STD-1560 layout (not QPL'd).

Insert Arrangements Views

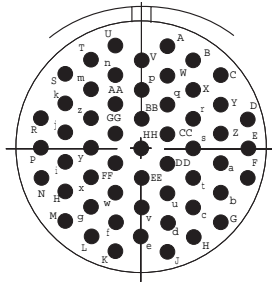

H55,  
55 # 20, I

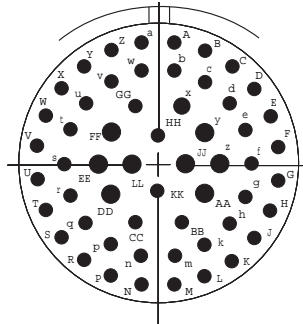

J4,  
8 # 16, 48 # 20, I

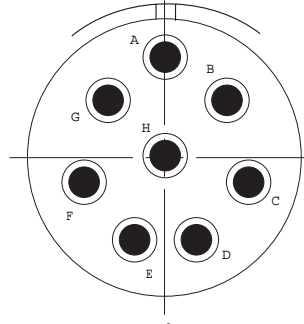

J8  
8 # 8 Twinax,  
Twinax

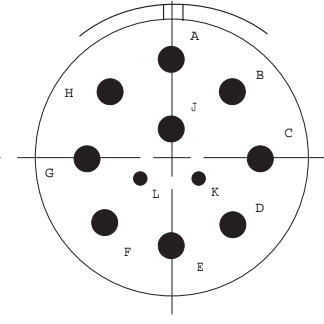

J11  
9 # 10, 2 # 20,  
N

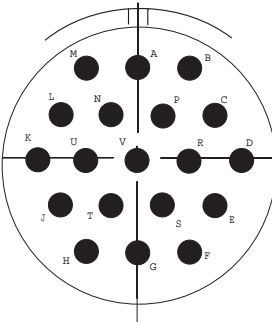

J19,  
19 # 12, I

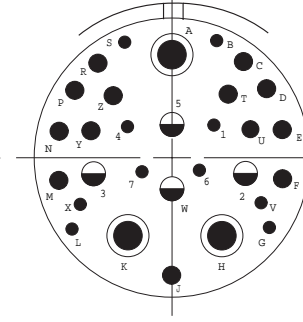

J20  
10 # 20, 13 # 16, 4 # 12, 3 # 8 Twinax,  
N / Coax / Twinax

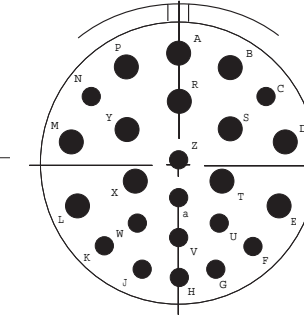

J24,  
12 # 12, 12 # 16, I

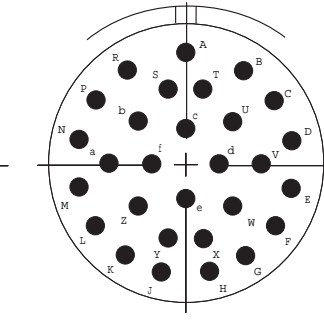

J29,  
29 # 16, I

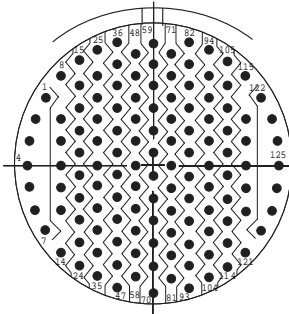

J35,  
128 # 22D, M

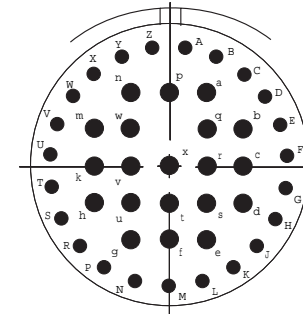

J43,  
20 # 16, 23 # 20, I

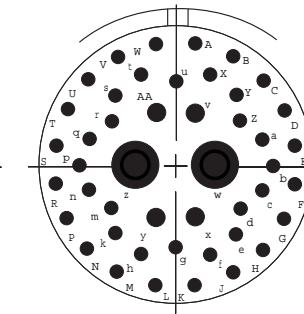

J46,  
40 # 20, 4 # 16, 2 # 8 Coax, I / Coax

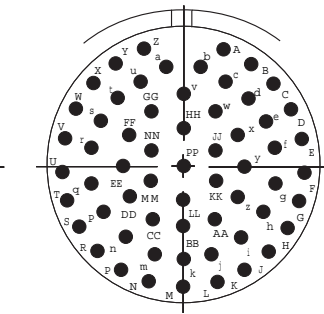

J61,  
61 # 20, I

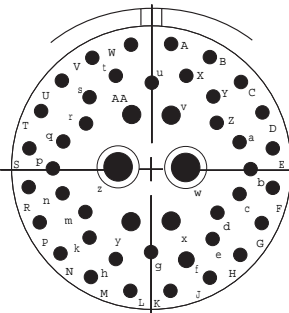

J90,  
40 # 20, 4 # 16, 2 # 8 Twinax,  
I / Twinax

38999 S III

# MIL-DTL-5015 / AS50151

## Features and Application

### Series III



## Features and Application

The threaded coupling, environmentally sealed MIL-DTL-5015 Series III connector with rear-removable crimp contacts was developed to replace the earlier solder type. This redesigned connector is intermateable and intermountable with the MIL-DTL-5015 Series I solder type (MS310\*) as well as the MIL-DTL- 83723 Series II (USAF) crimp type and MIL-DTL-5015 Series II Front Release (MS340\*). Thus, it provides for a minimum effort and high economy upgrade for existing applications.

These connectors are recommended for a wide range of applications, from commercial/industrial and mass transportation systems to the most stringent high reliability defense and aerospace requirements.

This family of connectors is offered in four receptacle mounting configurations. They include two square flange receptacles, both wall and box mounting; cable connecting receptacles; and jam nut receptacles which incorporate “O” ring seals, designed for rear panel “D” hole mounting.

Two plug styles are offered - standard plug with free rotating coupling nut with safety wire holes, and a self-locking, anti-decoupling plug, which eliminates the need for safety wiring.

Eighty-eight insert arrangements per MIL-STD-1651 are tooled and qualified to MIL-DTL-5015, utilizing 1 to 85 contacts. Contacts come in sizes 16, 12, 8, 4 and 0, terminating wire sizes from 20 gauge to 0 gauge.

These connectors are available in wide range of shell materials and finishes. Aluminum shells are offered in both electroless nickel and olive drab cadmium to both commercial and MS callouts. Other finishes such as anodic and zinc cobalt are available upon request to commercial callouts only. In addition, we offer passivated stainless steel shells with both standard and firewall-rated inserts, and carbon steel shells with firewall inserts.

**Lockwiring Eliminated** – Self-locking plug eliminates the need for lockwiring.

**Universal I/R Tool** – A single, expendable plastic tool is used for both insertion and removal of contacts.

**Insert Polarization** – Alternate insert clocking positions aid in mating of adjacent connectors having identical insert arrangement.

**Closed-Entry Socket Insert** – Hard dielectric socket face has lead-in chamfers for positive alignment of pins (even partially bent within pre-established limits) with sockets.

**Interfacial Pin Insert Seal** – Raised moisture barriers around each pin, which mate into lead-in chamfers of hard face socket insert, provide individual contact sealing. Interfacial seal is never touched by service tools.

**Elastomer Wire Sealing Grommet** – Sealing over a wide range of wire diameters is assured by a triple wire seal in each cavity at the rear of the connector.

**Superior Contact Stability** – Rear release crimp contact system features a stamped beryllium-copper retaining clip captivated by molded-in shoulders of each contact cavity in the insulator. A rear-inserted M81969 plastic tool expands the tines beyond the shoulder, releasing the contact.





**MIL-DTL-5015 /AS50151**  
**Performance Specifications**  
**MS345\*/AE55\***

## Performance Specifications

### Operating Temperature Range

Classes KS and LS: -55°C to +200°C (-67°F to +392°F)  
 Classes KT,W & Z\* : -55°C to +175°C (-67°F to +347°F)  
 Class L: -55°C to +200°C (-67°F to +392°F)  
 Class A\*: -55°C to +200°C (-67°F to +392°F)

### Material and Finish Data (Class)

KT – carbon steel shell, olive drab cadmium, firewall  
 KS – stainless steel shell, passivated, firewall (RoHS)  
 L – aluminum shell, electroless nickel finish  
 LS – stainless steel shell, passivated  
 W – aluminum shell, olive drab cadmium over nickel base  
 A\* – aluminum shell, black anodized finish  
 Z\* - Aluminum Shell, black zinc nickel finish (RoHS)

### Corrosion Resistance

Classes KS and LS withstand 1,000 hour salt spray.  
 Class KT withstands 96-hour salt spray.  
 Class L withstands 96-hour salt spray.  
 Class W withstands 1,000-hour salt spray.  
 Classes A\* and Z\* withstand 500 hour salt spray.

### Environmental Seal

Wired, mated connectors with specified accessories attached, shall meet the altitude-immersion test specified in MIL-DTL-5015.

### Durability

Minimum of 100 mating cycles

### Voltage Rating

Service Rating	Maximum Operating Voltage**		Test Voltage	Test Voltage	Test Voltage	Test Voltage
	(Sea Level)		Sea Level	50,000 Ft	70,000 Ft.	110,000 Ft.
	AC (RMS)	DC	V RMS	V RMS	V RMS	V RMS
Inst.	200	250	1000	400	260	200
A	500	700	2000	600	360	200
D	900	1250	2800	675	400	200
E	1250	1750	3500	750	440	200
B	1750	2450	4500	825	480	200
C	3000	4200	7000	975	560	200

\* Not MS approved, available to Aero-Electric part number only.

\*\*To be used by designer only as a guide.

### Shock and Vibration Requirements

Wired, mated connectors shall not be damaged, coupling ring shall not loosen, and there shall be no interruption of electrical continuity longer than 10 microseconds when subjected to the following:

### Shock

Mated connectors withstand a pulse of approximate half sine wave of 50 G magnitude with duration of 11 milliseconds applied in three axes per MIL-STD-1344, method 2004, test condition A.

### Vibration

Mated connectors withstand the following vibration levels:

- Random vibration per MIL-STD-1344, method 2005, and test condition VI, letter J.

### Shell-to-Shell Conductivity

Maximum potential drop shall not exceed:

- Class W = 5 millivolts
- All other classes (except A\*) = 50 millivolts

### Fluid Resistance

Connectors resist specified immersions in MIL-PRF-7808 (lubricating oil), MIL-PRF-23699 (lubricating oil), MIL-PRF-5606 (hydraulic fluid), M2-V Chevron oil, Coolanol 25, MIL-DTL-83133 (turbine fuel JP-8), MIL-DTL-5624 (turbine fuels JP-4 and JP-5), SAE-AMS1424 Type I (defrosting fluid), and other solvents and cleaning agents.

5015 S III

**MIL-DTL-5015 Series III /AS50151**  
**Part Number Development**  
**Rear Release**



**Military and Aero-Electric Part Number Development**

<b>Mil. Prefix</b>	<b>MS34</b>	<b>50</b>	<b>L</b>	<b>14S -</b>	<b>5</b>	<b>P</b>	<b>X</b>	
<b>Aero Prefix</b>	<b>AE5</b>	<b>50</b>	<b>L</b>	<b>14S -</b>	<b>5</b>	<b>P</b>	<b>X</b>	<b>-340</b>
<b>Shell Type</b>								
50 = Wall mount receptacle								
51 = Cable connecting receptacle								
52 = Box mount receptacle								
54 = Jam nut receptacle								
56 = Straight plug								
59 = Self-locking plug								
<b>Class (Material and Finish)</b>								
A = Aluminum shell, black anodized finish (Aero part number only)								
KS = Stainless steel shell, passivated, firewall (n/a in MS3451, MS3452, MS3454)								
KT = Carbon steel shell, cadmium finish, firewall (n/a in MS3451, MS3452, MS3454)								
LS = Stainless steel shell, passivated								
L = Aluminum shell, electroless nickel finish								
W = Aluminum shell, olive drab cadmium over electroless nickel base								
Z = Aluminum Shell, black zinc nickel finish (Aero p/n only) (RoHS)								
<b>Shell Size</b>								
8S, 10S, 10SL, 12, 12S, 14, 14S, 16, 16S, 18, 20, 22, 24, 28, 32, 36 or 40								
<b>Insert Arrangement</b>								
See pages 82 thru 87								
<b>Contact Style</b>								
P = Pin								
S = Socket								
A = Pin connector less pins (with intent to use non-std contact)								
B = Socket connector less sockets (with intent to use non-std contacts)								
<b>Polarization</b>								
N = Normal (not included in part number)								
W, X, Y or Z = Alternate insert polarizations (see pages 77 thru 81 for position availability)								
<b>Modification (applies to Aero part numbers only)</b>								
01 = Less contacts (is not marked on the part)								
340 = Connector kitted with M85049/31-XXX E-nut								
341 = Connector kitted with M85049/52-1-XXX straight clamp								
342 = Connector kitted with M85049/51-1-XXX right angle clamp								
Consult factory for other modifications								

**Note 1:** Each connector is furnished with contacts unless ordered less contacts (L/C) as follows: One spare contact for inserts requiring 2 to 26 of each contact and two spares for inserts with 27 or more of each size, and a minimum of one sealing plug up to 15% of the number contacts. No spares or seal plugs are provided with one contact layouts. No spares or seal plugs for contact sizes 0 and 4 are provided. For contact size 8, no contact spares are provided, but seal plugs are included. In addition, one insertion/removal tool of each size is included.

**Note 2:** KS and KT firewall classes are only available to Military part numbers for shell types MS3450, MS3456 and MS3459. KS and KT classes are available to Aero callouts for AE551 and 554, but not for AE552 (box mount receptacle).

**Note 3:** Proper part number marking has no "0" in front of single digit (numeric) shell size (8S) and no "0" in front of single digit layout. Examples: J MS3450W8S-1S and J MS3450W24-2PW. Please note that J or JAN marking is required immediately in front of MS part number.

**Threaded Coupling, Crimp Removable, Rear Release**

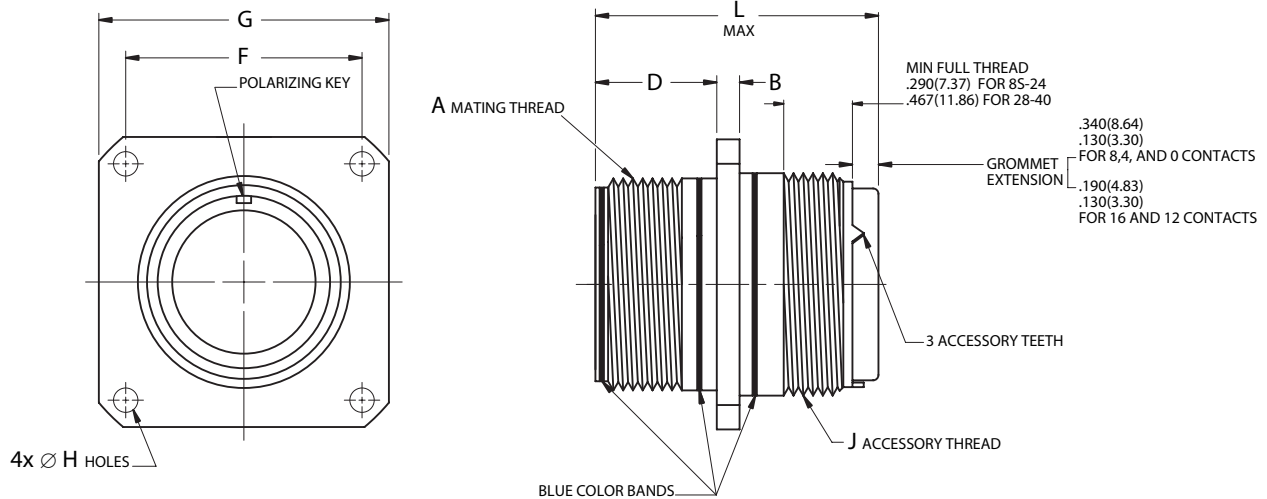

Page 65 Completed Part Number  
 Page 75 Contacts, Sealing Plugs and Tools  
 Pages 82-87 Insert Arrangements  
 Page 64 Performance Specifications  
 Pages 77-81 Insert Availability and Contact Information  
 Page 77 Polarization

**Note 1:** L MAX is same as L MAX for AE551 on next page.

**Note 2:** Maximum grommet O.D. is same as Ø E MAX for AE551 on next page.

5015 S III

Shell Size	A	B		D		F		G		Ø H				J
	Mating Thread Class 2A	±.015	±.38	+0.031 -0.000	+0.79 -0.00	(TP)		±.031	±.79	Classes L, LS, W +.010 -.005	Classes KS, KT +.010 -.005			Accessory Thread Class 2A
		inch	mm	inch	mm	inch	mm	inch	mm	inch	mm	inch	mm	
8S	1/2-28 UNEF	.083	2.11	.562	14.27	.594	15.09	.875	22.23	.120	3.05	.150	3.81	1/2-20UNF
10S	5/8-24 UNEF	.083	2.11	.562	14.27	.719	18.26	1.000	25.40	.120	3.05	.150	3.81	5/8-24UNEF
10SL	5/8-24 UNEF	.083	2.11	.562	14.27	.719	18.26	1.000	25.40	.120	3.05	.150	3.81	5/8-24UNEF
12	3/4-20 UNEF	.083	2.11	.750	19.05	.812	20.62	1.094	27.79	.120	3.05	.150	3.81	3/4-20UNEF
12S	3/4-20 UNEF	.083	2.11	.562	14.27	.812	20.62	1.094	27.79	.120	3.05	.150	3.81	3/4-20UNEF
14	7/8-20 UNEF	.083	2.11	.750	19.05	.906	23.01	1.188	30.18	.120	3.05	.150	3.81	7/8-20UNEF
14S	7/8-20 UNEF	.083	2.11	.562	14.27	.906	23.01	1.188	30.18	.120	3.05	.150	3.81	7/8-20UNEF
16	1-20 UNEF	.083	2.11	.750	19.05	.969	24.61	1.281	32.54	.120	3.05	.150	3.81	1-20UNEF
16S	1-20 UNEF	.083	2.11	.562	14.27	.969	24.61	1.281	32.54	.120	3.05	.150	3.81	1-20UNEF
18	1 1/8-18 UNEF	.125	3.18	.750	19.05	1.062	26.97	1.375	34.93	.120	3.05	.177	4.50	1-1/16-18UNEF
20	1 1/4-18 UNEF	.125	3.18	.750	19.05	1.156	29.36	1.500	38.10	.120	3.05	.177	4.50	1-3/16-18UNEF
22	1 3/8-18 UNEF	.125	3.18	.750	19.05	1.250	31.75	1.625	41.28	.120	3.05	.177	4.50	1-5/16-18UNEF
24	1 1/2-18 UNEF	.125	3.18	.812	20.62	1.375	34.93	1.750	44.45	.147	3.73	.177	4.50	1-7/16-18UNEF
28	1 3/4-18 UNS	.125	3.18	.812	20.62	1.562	39.67	2.000	50.80	.147	3.73	.177	4.50	1-3/4-18UNS
32	2-18 UNS	.125	3.18	.875	22.23	1.750	44.45	2.250	57.15	.173	4.39	.209	5.31	2-18UNS
36	2 1/4-16 UN	.125	3.18	.875	22.23	1.938	49.23	2.500	63.50	.173	4.39	.209	5.31	2-1/4-16UN
40	2 1/2-16 UN	.125	3.18	.875	22.23	2.188	55.58	2.750	69.85	.173	4.39	.209	5.31	2-1/2-16UN

**MS3451 per AS34511**  
**Cable Connecting Receptacle**  
**AE551**



**Threaded Coupling, Crimp Removable, Rear Release**

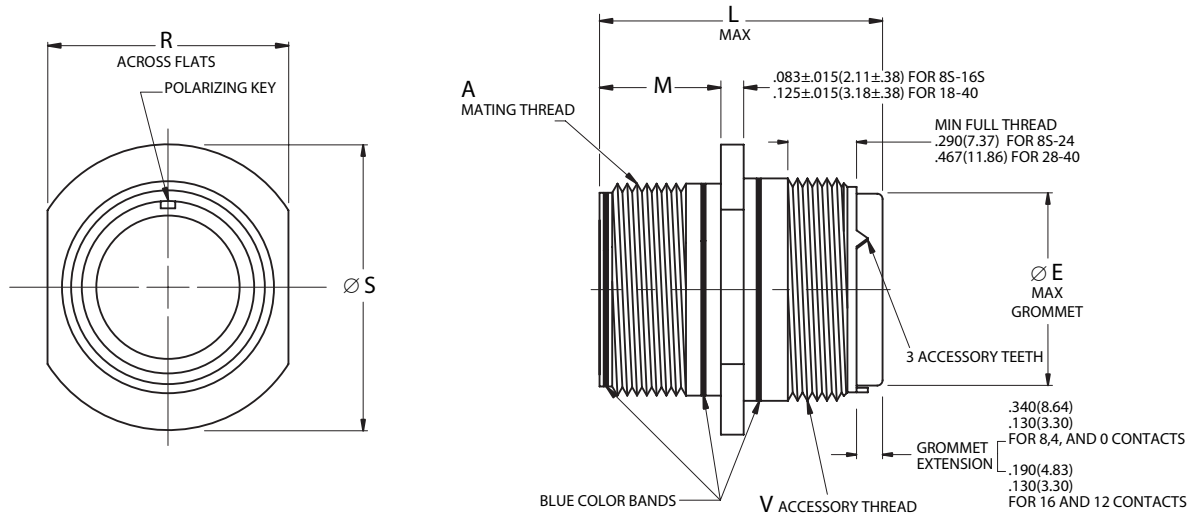

- Page 65 Completed Part Number
- Page 75 Contacts, Sealing Plugs and Tools
- Pages 82–87 Insert Arrangements
- Page 64 Performance Specifications
- Pages 77–81 Insert Availability and Contact Information
- Page 77 Polarization

5015 S III

Shell Size	A	Ø E		L MAX				M		R		Ø S		V
	Mating Thread Class 2A	Maximum		16 & 12 Contacts		8, 4 & 0 Contacts		+.031 -.000				±.031 ±.79		Accessory Thread Class 2A
		inch	mm	inch	mm	inch	mm	inch	mm	inch	mm	inch	mm	
8S	1/2-28 UNEF	.305	7.75	2.031	51.59	–	–	.562	14.27	.504/.496	12.80/12.60	.729	18.52	1/2-20UNF
10S	5/8-24 UNEF	.405	10.29	2.031	51.59	–	–	.562	14.27	.629/.621	15.98/15.77	.854	21.69	5/8-24UNEF
10SL	5/8-24 UNEF	.405	10.29	2.031	51.59	–	–	.562	14.27	.629/.621	15.98/15.77	.854	21.69	5/8-24UNEF
12	3/4-20 UNEF	.549	13.94	2.125	53.98	–	–	.750	19.05	.754/.746	19.15/18.95	.974	24.74	3/4-20UNEF
12S	3/4-20 UNEF	.549	13.94	2.031	51.59	–	–	.562	14.27	.754/.746	19.15/18.95	.974	24.74	3/4-20UNEF
14	7/8-20 UNEF	.665	16.89	2.125	53.98	–	–	.750	19.05	.879/.871	22.33/22.12	1.099	27.91	7/8-20UNEF
14S	7/8-20 UNEF	.665	16.89	2.031	51.59	–	–	.562	14.27	.879/.871	22.33/22.12	1.099	27.91	7/8-20UNEF
16	1-20 UNEF	.790	20.07	2.125	53.98	2.500	63.50	.750	19.05	1.005/.996	25.53/25.30	1.224	31.09	1-20UNEF
16S	1-20 UNEF	.790	20.07	2.031	51.59	–	–	.562	14.27	1.005/.996	25.53/25.30	1.224	31.09	1-20UNEF
18	1 1/8-18 UNEF	.869	22.07	2.125	53.98	2.500	63.50	.750	19.05	1.131/1.121	28.73/28.47	1.349	34.26	1-1/16-18UNEF
20	1 1/4-18 UNEF	.994	25.25	2.125	53.98	2.500	63.50	.750	19.05	1.256/1.246	31.90/31.65	1.474	37.44	1-3/16-18UNEF
22	1 3/8-18 UNEF	1.119	28.42	2.125	53.98	2.500	63.50	.750	19.05	1.381/1.371	35.08/34.82	1.599	40.61	1-5/16-18UNEF
24	1 1/2-18 UNEF	1.244	31.60	2.125	53.98	2.500	63.50	.812	20.62	1.506/1.496	38.25/38.00	1.715	43.56	1-7/16-18UNEF
28	1 3/4-18 UNS	1.465	37.21	2.125	53.98	2.500	63.50	.812	20.62	1.756/1.746	44.60/44.35	1.974	50.14	1-3/4-18UNS
32	2-18 UNS	1.715	43.56	2.125	53.98	2.500	63.50	.875	22.23	2.007/1.996	50.98/50.70	2.224	56.49	2-18UNS
36	2 1/4-16 UN	1.930	49.02	2.125	53.98	2.500	63.50	.875	22.23	2.257/2.246	57.33/57.05	2.474	62.84	2-1/4-16UN
40	2 1/2-16 UN	2.145	54.48	2.125	53.98	2.500	63.50	.875	22.23	2.511/2.496	63.78/63.40	2.724	69.19	2-1/2-16UN

**Threaded Coupling, Crimp Removable, Rear Release**

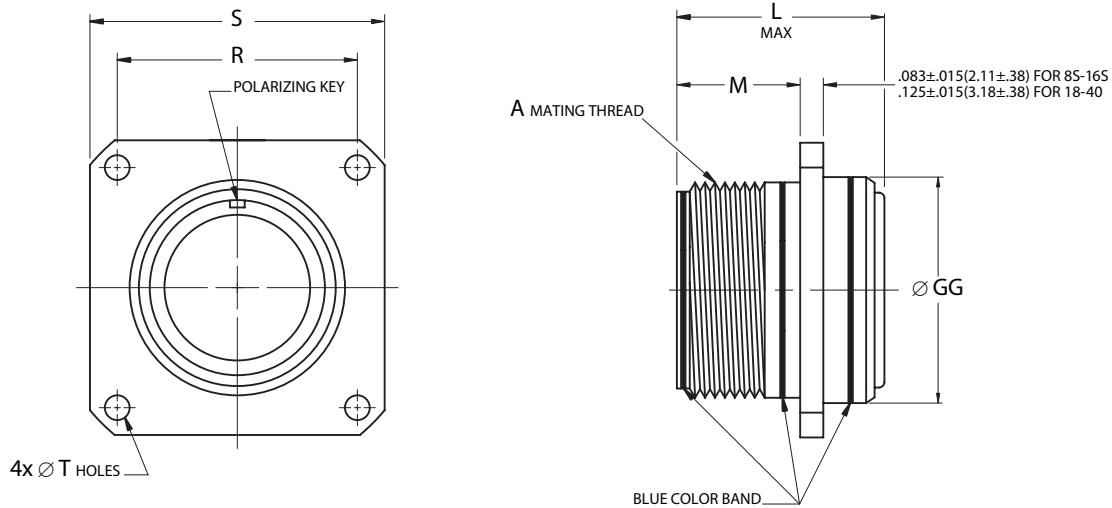

Page 65 Completed Part Number  
 Page 75 Contacts, Sealing Plugs and Tools  
 Pages 82–87 Insert Arrangements  
 Page 64 Performance Specifications  
 Pages 77–81 Insert Availability and Contact Information  
 Page 77 Polarization

**Note 1:** The insulation material shall be above, flush with, or no more than .015 inches (.38 mm) below the metal shell.

5015 S III

Shell Size	A	Ø GG		L MAX				M		R		S		Ø T	
	Mating Thread Class 2A	±.016	±.41	16 & 12 Contacts		8, 4 & 0 Contacts		+0.031	+0.79	(TP)		±.031	±.79	+0.010	+0.25
		inch	mm	inch	mm	inch	mm	inch	mm	inch	mm	inch	mm	inch	mm
85	1/2-28 UNEF	.500	12.70	1.662	42.21	-	-	.562	14.27	.594	15.09	.875	22.23	.120	3.05
10S	5/8-24 UNEF	.625	15.88	1.662	42.21	-	-	.562	14.27	.719	18.26	1.000	25.40	.120	3.05
10SL	5/8-24 UNEF	.625	15.88	1.662	42.21	-	-	.562	14.27	.719	18.26	1.000	25.40	.120	3.05
12	3/4-20 UNEF	.750	19.05	1.662	42.21	-	-	.750	19.05	.812	20.62	1.094	27.79	.120	3.05
12S	3/4-20 UNEF	.750	19.05	1.662	42.21	-	-	.562	14.27	.812	20.62	1.094	27.79	.120	3.05
14	7/8-20 UNEF	.875	22.23	1.662	42.21	-	-	.750	19.05	.906	23.01	1.188	30.18	.120	3.05
14S	7/8-20 UNEF	.875	22.23	1.662	42.21	-	-	.562	14.27	.906	23.01	1.188	30.18	.120	3.05
16	1-20 UNEF	1.000	25.40	1.662	42.21	1.937	49.20	.750	19.05	.969	24.61	1.281	32.54	.120	3.05
16S	1-20 UNEF	1.000	25.40	1.662	42.21	-	-	.562	14.27	.969	24.61	1.281	32.54	.120	3.05
18	1 1/8-18 UNEF	1.062	26.97	1.662	42.21	1.937	49.20	.750	19.05	1.062	26.97	1.375	34.93	.120	3.05
20	1 1/4-18 UNEF	1.187	30.15	1.662	42.21	1.937	49.20	.750	19.05	1.156	29.36	1.500	38.10	.120	3.05
22	1 3/8-18 UNEF	1.312	33.32	1.662	42.21	1.937	49.20	.750	19.05	1.250	31.75	1.625	41.28	.120	3.05
24	1 1/2-18 UNEF	1.437	36.50	1.662	42.21	1.937	49.20	.812	20.62	1.375	34.93	1.750	44.45	.147	3.73
28	1 3/4-18 UNS	1.750	44.45	1.662	42.21	1.937	49.20	.812	20.62	1.562	39.67	2.000	50.80	.147	3.73
32	2-18 UNS	2.000	50.80	1.662	42.21	1.937	49.20	.875	22.23	1.750	44.45	2.250	57.15	.173	4.39
36	2 1/4-16 UN	2.250	57.15	1.662	42.21	1.937	49.20	.875	22.23	1.938	49.23	2.500	63.50	.173	4.39
40	2 1/2-16 UN	2.500	63.50	1.662	42.21	1.937	49.20	.875	22.23	2.188	55.58	2.750	69.85	.173	4.39



**MS3454 per AS34541**  
**Jam Nut Receptacle**  
**AE554**



**Threaded Coupling, Crimp Removable, Rear Release**

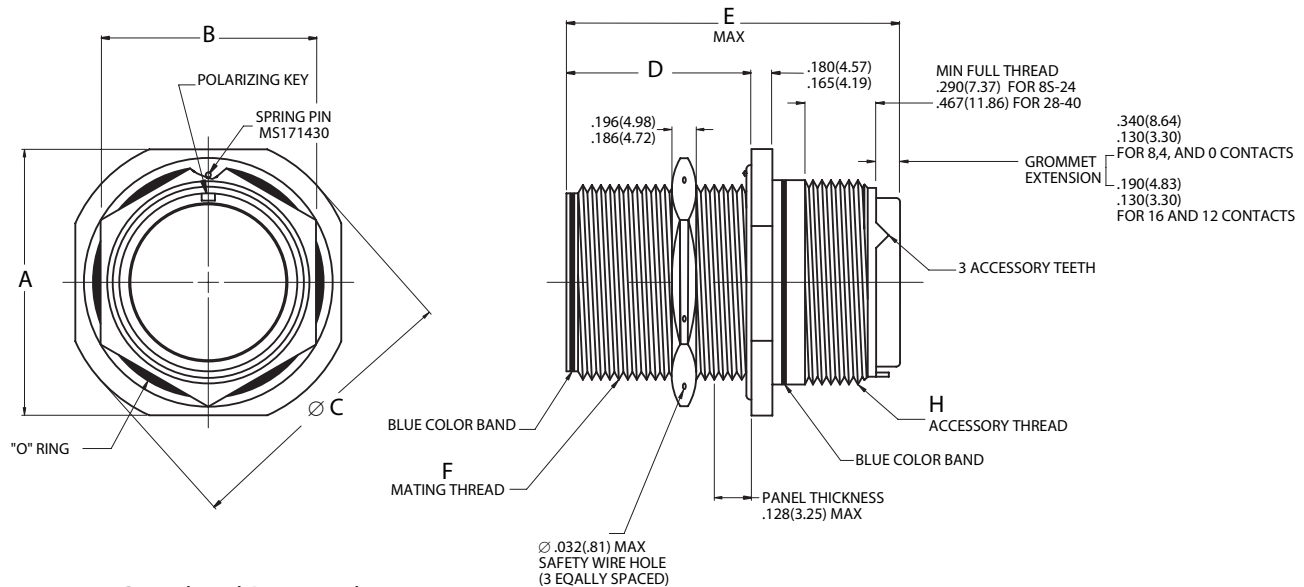

Page 65 Completed Part Number  
 Page 75 Contacts, Sealing Plugs and Tools  
 Pages 82–87 Insert Arrangements  
 Page 64 Performance Specifications  
 Pages 77–81 Insert Availability and Contact Information  
 Page 77 Polarization

**Note:** Maximum grommet O.D. is same as Ø E MAX on next page.

Shell Size	A		B		Ø C		D		E MAX		F	H		
	±.005	±.13	±.010	±.25	±.005	±.13	±.005	±.13	16 & 12 Contacts	8, 4 & 0 Contacts	Mating Thread Class 2A	Accessory Thread Class 2A		
	inch	mm	inch	mm	inch	mm	inch	mm	inch	mm				
8S	1.187	30.15	.687	17.45	1.272	32.31	.720	18.29	2.031	51.59	–	–	1/2-28 UNEF	1/2-20UNF
10S	1.312	33.32	.812	20.62	1.397	35.48	.720	18.29	2.031	51.59	–	–	5/8-24 UNEF	5/8-24UNEF
10SL	1.312	33.32	.812	20.62	1.397	35.48	.720	18.29	2.031	51.59	–	–	5/8-24 UNEF	5/8-24UNEF
12	1.437	36.50	.937	23.80	1.522	38.66	.970	24.64	2.125	53.98	–	–	3/4-20 UNEF	3/4-20UNEF
12S	1.437	36.50	.937	23.80	1.522	38.66	.720	18.29	2.031	51.59	–	–	3/4-20 UNEF	3/4-20UNEF
14	1.562	39.67	1.125	28.58	1.647	41.83	.970	24.64	2.125	53.98	–	–	7/8-20 UNEF	7/8-20UNEF
14S	1.562	39.67	1.125	28.58	1.647	41.83	.720	18.29	2.031	51.59	–	–	7/8-20 UNEF	7/8-20UNEF
16	1.687	42.85	1.250	31.75	1.772	45.01	.970	24.64	2.125	53.98	2.500	63.50	1-20 UNEF	1-20UNEF
16S	1.687	42.85	1.250	31.75	1.772	45.01	.720	18.29	2.031	51.59	–	–	1-20 UNEF	1-20UNEF
18	1.812	46.02	1.375	34.93	1.897	48.18	.970	24.64	2.125	53.98	2.500	63.50	1 1/8-18 UNEF	1-1/16-18UNEF
20	1.937	49.20	1.500	38.10	2.022	51.36	.970	24.64	2.125	53.98	2.500	63.50	1 1/4-18 UNEF	1-3/16-18UNEF
22	2.156	54.76	1.625	41.28	2.241	56.92	.970	24.64	2.125	53.98	2.500	63.50	1 3/8-18 UNEF	1-5/16-18UNEF
24	2.281	57.94	1.750	44.45	2.366	60.10	.970	24.64	2.125	53.98	2.500	63.50	1 1/2-18 UNEF	1-7/16-18UNEF
28	2.531	64.29	2.000	50.80	2.616	66.45	.970	24.64	2.125	53.98	2.500	63.50	1 3/4-18 UNS	1-3/4-18UNS
32	2.781	70.64	2.375	60.33	2.866	72.80	.970	24.64	2.125	53.98	2.500	63.50	2-18 UNS	2-18UNS
36	3.031	76.99	2.625	66.68	3.116	79.15	.970	24.64	2.125	53.98	2.500	63.50	2 1/4-16 UN	2-1/4-16UN
40	3.281	83.34	2.875	73.03	3.366	85.50	.970	24.64	2.125	53.98	2.500	63.50	2 1/2-16 UN	2-1/2-16UN

**Threaded Coupling, Crimp Removable, Rear Release**

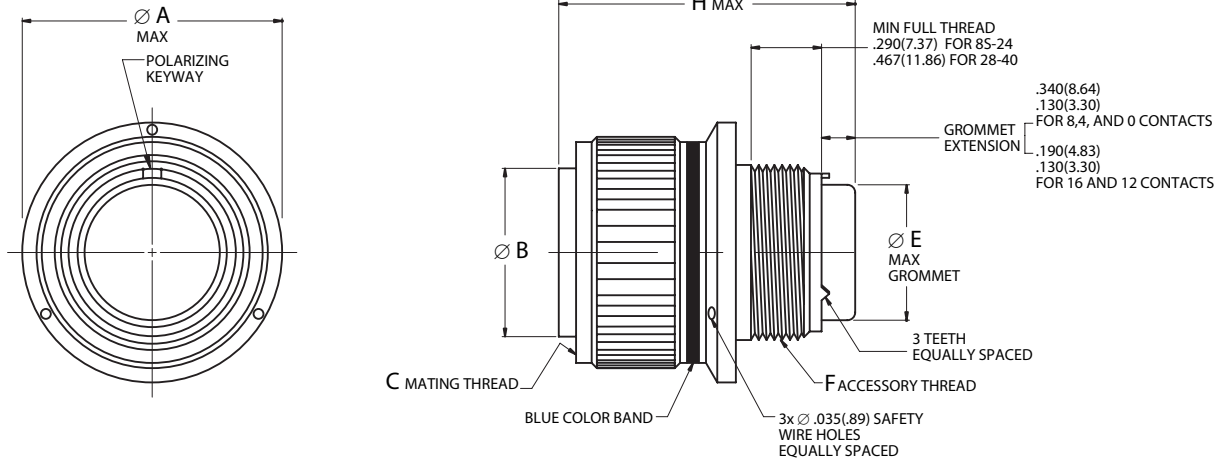

Page 65 Completed Part Number  
 Page 75 Contacts, Sealing Plugs and Tools  
 Pages 82-87 Insert Arrangements  
 Page 64 Performance Specifications  
 Pages 77-81 Insert Availability and Contact Information  
 Page 77 Polarization

5015 S III

Shell Size	$\varnothing A$		$\varnothing B$		C	$\varnothing E$		F	H MAX			
	Maximum		$\pm .005$	$\pm .13$		Mating Thread Class 2B	Maximum		Accessory Thread Class 2A	16 & 12 Contacts		8, 4 & 0 Contacts
	inch	mm	inch	mm		inch	mm		inch	mm	inch	mm
8S	.844	21.44	.360	9.14	1/2-28 UNEF	.305	7.75	1/2-20UNF	2.031	51.59	-	-
10S	.969	24.61	.435	11.05	5/8-24 UNEF	.405	10.29	5/8-24UNEF	2.031	51.59	-	-
10SL	.969	24.61	.443*	11.25*	5/8-24 UNEF	.405	10.29	5/8-24UNEF	2.031	51.59	-	-
12	1.062	26.97	.550	13.97	3/4-20 UNEF	.549	13.94	3/4-20UNEF	2.125	53.98	-	-
12S	1.062	26.97	.550	13.97	3/4-20 UNEF	.549	13.94	3/4-20UNEF	2.031	51.59	-	-
14	1.156	29.36	.670	17.02	7/8-20 UNEF	.665	16.89	7/8-20UNEF	2.125	53.98	-	-
14S	1.156	29.36	.670	17.02	7/8-20 UNEF	.665	16.89	7/8-20UNEF	2.031	51.59	-	-
16	1.250	31.75	.800	20.32	1-20 UNEF	.790	20.07	1-20UNEF	2.125	53.98	2.500	63.50
16S	1.250	31.75	.800	20.32	1-20 UNEF	.790	20.07	1-20UNEF	2.031	51.59	-	-
18	1.344	34.14	.925	23.50	1 1/8-18 UNEF	.869	22.07	1-1/16-18UNEF	2.125	53.98	2.500	63.50
20	1.469	37.31	1.045	26.54	1 1/4-18 UNEF	.994	25.25	1-3/16-18UNEF	2.125	53.98	2.500	63.50
22	1.594	40.49	1.170	29.72	1 3/8-18 UNEF	1.119	28.42	1-5/16-18UNEF	2.125	53.98	2.500	63.50
24	1.719	43.66	1.295	32.89	1 1/2-18 UNEF	1.244	31.60	1-7/16-18UNEF	2.125	53.98	2.500	63.50
28	1.969	50.01	1.515	38.48	1 3/4-18 UNS	1.465	37.21	1-3/4-18UNS	2.125	53.98	2.500	63.50
32	2.219	56.36	1.765	44.83	2-18 UNS	1.715	43.56	2-18UNS	2.125	53.98	2.500	63.50
36	2.469	62.71	1.975	50.17	2 1/4-16 UN	1.930	49.02	2-1/4-16UN	2.125	53.98	2.500	63.50
40	2.719	69.06	2.225	56.52	2 1/2-16 UN	2.145	54.48	2-1/2-16UN	2.125	53.98	2.500	63.50

\* Tolerance for this dimension is  $\pm .003(.08)$

**MS3459 per AS34591**  
**Self-Locking Plug**  
**AE559**



**Threaded Coupling, Crimp Removable, Rear Release**

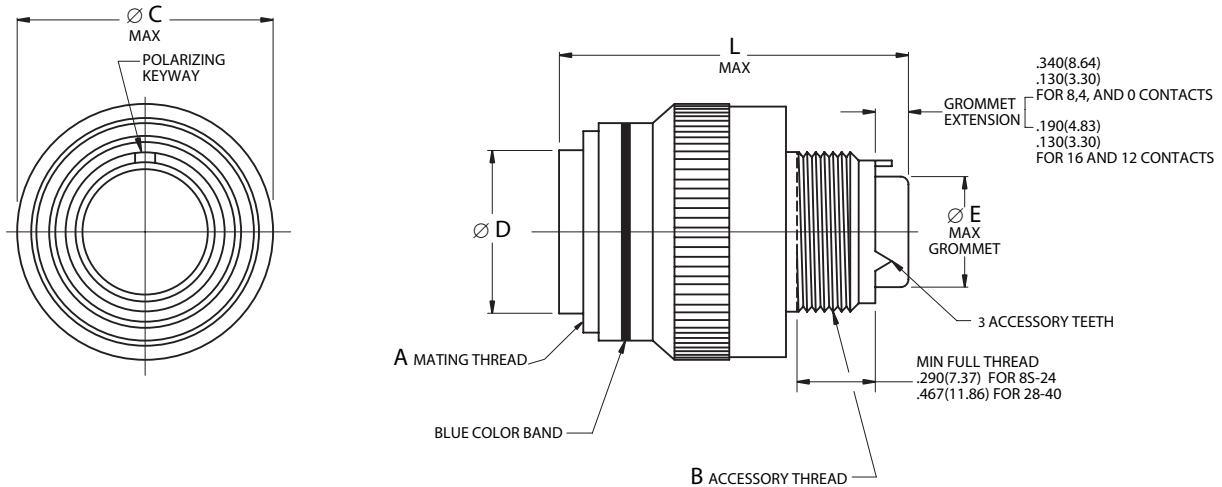

Page 65	Completed Part Number
Page 75	Contacts, Sealing Plugs and Tools
Pages 82–87	Insert Arrangements
Page 64	Performance Specifications
Pages 77–81	Insert Availability and Contact Information
Page 77	Polarization

5015 S III

Shell Size	A	B	$\varnothing C$		$\varnothing D$		$\varnothing E$		L MAX			
	Mating Thread Class 2B	Accessory Thread Class 2A	Maximum		$\pm .005$	$\pm .13$	Maximum		16 & 12 Contacts	8, 4 & 0 Contacts		
			inch	mm	inch	mm	inch	mm	inch	mm		
8S	1/2-28 UNEF	1/2-20UNF	.963	24.46	.360	9.14	.305	7.75	2.031	51.59	-	-
10S	5/8-24 UNEF	5/8-24UNEF	1.088	27.64	.435	11.05	.405	10.29	2.031	51.59	-	-
10SL	5/8-24 UNEF	5/8-24UNEF	1.088	27.64	.443*	11.25*	.405	10.29	2.031	51.59	-	-
12	3/4-20 UNEF	3/4-20UNEF	1.213	30.81	.550	13.97	.549	13.94	2.125	53.98	-	-
12S	3/4-20 UNEF	3/4-20UNEF	1.213	30.81	.550	13.97	.549	13.94	2.031	51.59	-	-
14	7/8-20 UNEF	7/8-20UNEF	1.358	34.49	.670	17.02	.665	16.89	2.125	53.98	-	-
14S	7/8-20 UNEF	7/8-20UNEF	1.358	34.49	.670	17.02	.665	16.89	2.031	51.59	-	-
16	1-20 UNEF	1-20UNEF	1.463	37.16	.800	20.32	.790	20.07	2.125	53.98	2.500	63.50
16S	1-20 UNEF	1-20UNEF	1.463	37.16	.800	20.32	.790	20.07	2.031	51.59	-	-
18	1 1/8-18 UNEF	1-1/16-18UNEF	1.588	40.34	.925	23.50	.869	22.07	2.125	53.98	2.500	63.50
20	1 1/4-18 UNEF	1-3/16-18UNEF	1.713	43.51	1.045	26.54	.994	25.25	2.125	53.98	2.500	63.50
22	1 3/8-18 UNEF	1-5/16-18UNEF	1.788	45.42	1.170	29.72	1.119	28.42	2.125	53.98	2.500	63.50
24	1 1/2-18 UNEF	1-7/16-18UNEF	1.963	49.86	1.295	32.89	1.244	31.60	2.125	53.98	2.500	63.50
28	1 3/4-18 UNS	1-3/4-18UNS	2.213	56.21	1.515	38.48	1.465	37.21	2.125	53.98	2.500	63.50
32	2-18 UNS	2-18UNS	2.463	62.56	1.765	44.83	1.715	43.56	2.125	53.98	2.500	63.50
36	2 1/4-16 UN	2-1/4-16UN	2.713	68.91	1.975	50.17	1.930	49.02	2.125	53.98	2.500	63.50
40	2 1/2-16 UN	2-1/2-16UN	2.963	75.26	2.225	56.52	2.145	54.48	2.125	53.98	2.500	63.50

\* Tolerance for this dimension is  $\pm .003(.08)$

**Panel Cutouts**

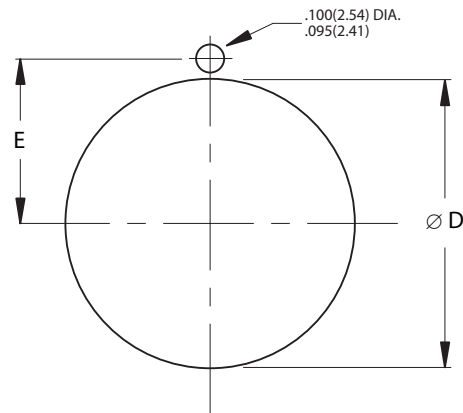
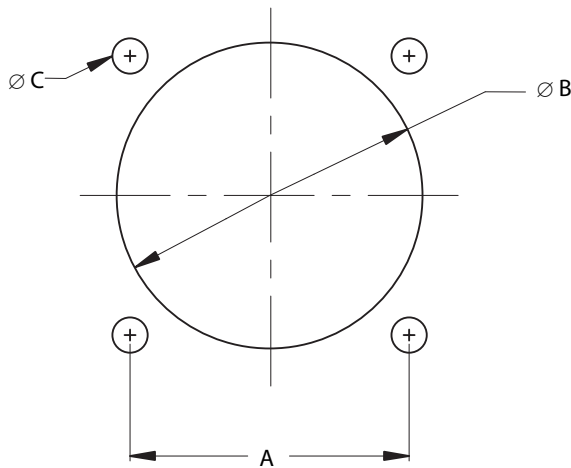

MS3454 (AE554) CUTOUT

5015 S III

**Flange and Jam Nut Mounting Dimensions**

Shell Size	A		Ø B		Ø C				Ø D		E	
	(TP)		±.010	±.25	Classes L, LS, W		Classes KS, KT		+.015	+.38	±.005	±.13
	inch	mm	inch	mm	inch	mm	inch	mm	inch	mm		
8S	.594	15.09	.562	14.27	.120	3.05	.150	3.81	.505	12.83	.323	8.20
10S, 10SL	.719	18.26	.688	17.48	.120	3.05	.150	3.81	.630	16.00	.385	9.78
12, 12S	.812	20.62	.812	20.62	.120	3.05	.150	3.81	.755	19.18	.448	11.38
14, 14S	.906	23.01	.938	23.83	.120	3.05	.150	3.81	.880	22.35	.510	12.95
16, 16S	.969	24.61	1.062	26.97	.120	3.05	.150	3.81	1.005	25.53	.573	14.55
18	1.062	26.97	1.188	30.18	.120	3.05	.177	4.50	1.130	28.70	.635	16.13
20	1.156	29.36	1.312	33.32	.120	3.05	.177	4.50	1.255	31.88	.698	17.73
22	1.250	31.75	1.438	36.53	.120	3.05	.177	4.50	1.380	35.05	.760	19.30
24	1.375	34.93	1.562	39.67	.147	3.73	.177	4.50	1.505	38.23	.823	20.90
28	1.562	39.67	1.812	46.02	.147	3.73	.177	4.50	1.755	44.58	.948	24.08
32	1.750	44.45	2.062	52.37	.173	4.39	.209	5.31	2.005	50.93	1.073	27.25
36	1.938	49.23	2.312	58.72	.173	4.39	.209	5.31	2.255	57.28	1.198	30.43
40	2.188	55.58	2.562	65.07	.173	4.39	.209	5.31	2.505	63.63	1.323	33.60

**MS25042**  
**Protective Cover, PLUG**  
**AE542**



**Protective Cover, Plug**

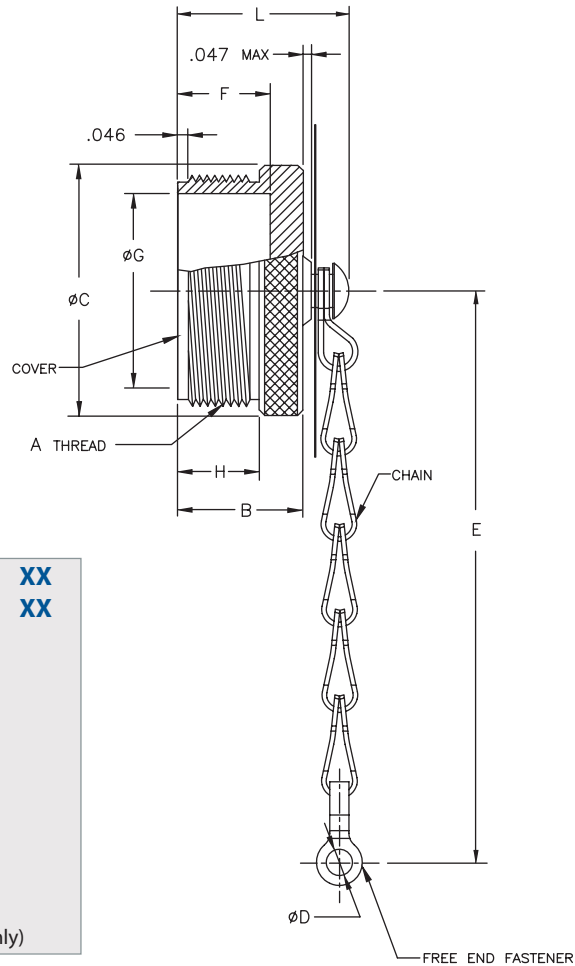

**Part Number Configuration**

<b>MIL. Prefix</b>	<b>MS25042-</b>	<b>XX</b>	<b>XX</b>
<b>Aero Prefix</b>	<b>AE542-</b>	<b>XX</b>	<b>XX</b>
<b>Shell Size</b>			
8 THRU 44 (Note: single digit for shell size 8)			
<b>Material Finish</b>			
DA = Aluminum, Hard Black Anodize			
D = Aluminum, Cadmium Olive Drab			
L = Aluminum, Electroless Nickel Plate (Aero p/n only)			
LS = Stainless Steel, Passivated (Aero p/n only)			
KT = Carbon Steel, Cadmium Olive Drab (Aero p/n only)			
BN = Aluminum, Black Nickel Plate (Aero p/n only)			
BZ = Bronze (Aero p/n only)			
Z = Aluminum Shell, black zinc nickel finish (RoHS)(Aero p/n only)			

SHELL SIZE	Coupling Shell Size	A Thread Class 2A	B Max.	ØC Max.	ØD +.010 -0.005	E ±1 Link	F .016	ØG .016	H Min.	L Max.
8	8S	.500-28 UNEF	.656	.562	.156	4.000	.562	.375	.380	.969
10	10S, 10SL	.625-24 UNEF	.844	.687	.156	4.000	.562	.469	.380	.969
12	12, 12S	.750-20 UNEF	.844	.812	.156	4.500	.750	.562	.530	1.156
14	14, 14S	.875-20 UNEF	.844	0.937	.156	4.500	.750	.688	.530	1.156
16	16, 16S	1.000-20 UNEF	.844	1.062	.156	4.500	.750	.812	.530	1.156
18	18	1.125-18 UNEF	.844	1.187	.156	4.500	.750	.938	.530	1.156
20	20	1.250-18 UNEF	.844	1.312	.187	5.000	.750	1.062	.530	1.156
22	22	1.375-18 UNEF	.844	1.437	.187	5.000	.750	1.188	.530	1.156
24	24	1.500-18 UNEF	.844	1.562	.187	5.500	.750	1.312	.530	1.156
28	28	1.750-18 UNS	.844	1.812	.187	7.750	.750	1.531	.530	1.156
32	32	2.000-18UNS	.844	2.062	.218	7.750	.750	1.781	.530	1.156
36	36	2.250-16 UN	.844	2.312	.218	7.750	.750	2.000	.530	1.156
40	40	2.500-16 UN	.844	2.562	.218	7.750	.750	2.250	.530	1.156
44	44	2.750-16 UN	.844	2.812	.218	7.750	.750	2.500	.590	1.156

5015 S III



**Protective Cover, Receptacle**

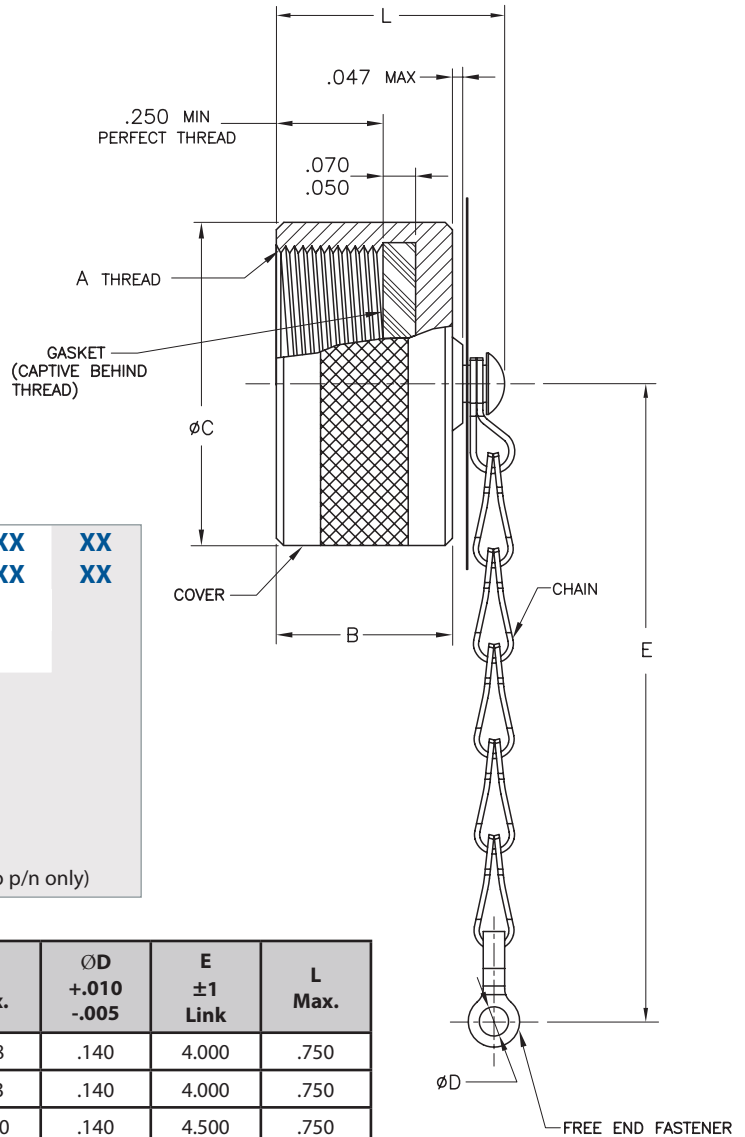

**Part Number Configuration**

<b>MIL. Prefix</b>	<b>MS25043-</b>	<b>XX</b>	<b>XX</b>
<b>Aero Prefix</b>	<b>AE543-</b>	<b>XX</b>	<b>XX</b>
<b>Shell Size</b>	<b>8 THRU 44 (Note: single digit for shell size 8)</b>		
<b>Material Finish</b>	<ul style="list-style-type: none"> <li><b>DA</b> = Aluminum, Hard Black Anodize</li> <li><b>D</b> = Aluminum, Cadmium Olive Drab</li> <li><b>L</b> = Aluminum, Electroless Nickel Plate (Aero p/n only)</li> <li><b>LS</b> = Stainless Steel, Passivated (Aero p/n only)</li> <li><b>KT</b> = Carbon Steel, Cadmium Olive Drab (Aero p/n only)</li> <li><b>BN</b> = Aluminum, Black Nickel Plate (Aero p/n only)</li> <li><b>BZ</b> = Bronze (Aero p/n only)</li> <li><b>Z</b> = Aluminum Shell, black zinc nickel finish (RoHS) (Aero p/n only)</li> </ul>		

SHELL SIZE	Coupling Shell Size	A Thread Class 2B	B Max.	ØC Max.	ØD +.010 -0.005	E ±1 Link	L Max.
8	8S	.500-28 UNEF	.469	.688	.140	4.000	.750
10	10S, 10SL	.625-24 UNEF	.469	.813	.140	4.000	.750
12	12, 12S	.750-20 UNEF	.469	1.000	.140	4.500	.750
14	14, 14S	.875-20 UNEF	.469	1.125	.140	4.500	.750
16	16, 16S	1.000-20 UNEF	.469	1.188	.140	4.500	.750
18	18	1.125-18 UNEF	.469	1.344	.140	4.500	.750
20	20	1.250-18 UNEF	.469	1.469	.140	5.000	.750
22	22	1.375-18 UNEF	.469	1.594	.140	5.000	.750
24	24	1.500-18 UNEF	.469	1.719	.171	5.500	.750
28	28	1.750-18 UNS	.531	1.969	.171	7.750	.812
32	32	2.000-18UNS	.531	2.219	.187	7.750	.812
36	36	2.250-16 UN	.531	2.469	.187	7.750	.812
40	40	2.500-16 UN	.531	2.718	.187	7.750	.812
44	44	2.750-16 UN	.531	2.969	.187	7.750	.812

5015 S III

# MIL-DTL-5015 series III/AS50151

## Contacts, Tools and Seal Plugs

### MS345\*/AE55\*



#### Contacts, Plastic Insertion/Removal Tools and Seal Plugs

Contact Size	Application	Pin Contacts	Socket Contacts	Seal Plugs	Insertion/Removal Tools
	Type	Military No.	Military No.	Military No.	Military No.
					Plastic
16S	Power/Signal	N/A	M39029/30-217	MS27488-16-1	M81969/14-03
16	Power/Signal	M39029/29-212	M39029/30-218		
12	Power/Signal	M39029/29-213	M39029/30-219	MS27488-12-1	M81969/14-04
8	Power	M39029/29-214*	M39029/30-220*	MS27488-8-1	M81969/14-06
4	Power	M39029/29-215*	M39029/30-221*	MS27488-4-1**	M81969/14-07
0	Power	M39029/29-216*	M39029/30-222*	MS27488-0-1**	M81969/14-08

\* No spare size 0, 4 and 8 contacts are provided in connector contact packages.

\*\* Not supplied as part of connector contact packages.

#### Crimping and Metal Insertion/Extraction Tools

Contact Size	Crimp Tool	Positioner	Die Set	Locator	Extraction Tool
		Pin & Socket Contacts	Pin & Socket Contacts	Pin & Socket Contacts	Metal
	Military No.	Military No.	Military No.	Military No.	Military No.
16/16S	M22520/1-01	M22520/1-02	N/A	N/A	M81969/8-208
12	M22520/1-01	M22520/1-02	N/A	N/A	M81969/8-210
8	M22520/23-01	N/A	M22520/23-02	M22520/23-09	M81969/15-01
4	M22520/23-01	N/A	M22520/23-03	M22520/23-11	M81969/15-02
0	M22520/23-01	N/A	M22520/23-04	M22520/23-13	M81969/15-03

#### Contact and Wire Data

Contact Size	Test Current	Voltage	Crimp Well Data			Wire Range		Finished Wire $\phi$ Range			
	DC Test	Max. Drop	Well Dia.	Minimum Well Dept		AWG	$\text{mm}^2$	Minimum		Maximum	
	Amps	Millivolts	inch	inch	mm			inch	mm	inch	mm
16/16S	13	49	.067 $\pm$ .001	.250	6.35	20-16	0.52-1.31	.053	1.35	.103	2.62
12	23	42	.100 $\pm$ .002	.250	6.35	14-12	2.08-3.31	.085	2.16	.158	4.01
8	46	26	.181 $\pm$ .002	.485	12.32	10-8†	5.26-8.37	.132	3.35	.255	6.48
4	80	23	.281 $\pm$ .002	.485	12.32	6-4†	13.30-21.15	.237	6.02	.370	9.40
0	150	21	.453 $\pm$ .002	.580	14.73	2-0†	33.63-53.48	.360	9.14	.550	13.97

† MS3348 bushings required in crimp barrel to accommodate 10, 6 and 2 wire gauges. Bushings are ordered separately.

**Note 1:** 16S socket contacts are only used in shell sizes 8S, 10S, 10SL, 12S, 14S and 16S.

**Note 2:** Test Current and Maximum Voltage Drop when tested with silver-plated wire at 25°C.

**Note 3:** Metal Insertion tool is not req'd for size 8, 4 and 0 contacts. Metal insertion tool for size 16 contacts = M81969/8-207. Metal insertion tool for size 12 contacts = M81969/8-209.



**MIL-DTL-5015 series III/AS50151**  
**Contact Installation Instructions**  
**MS345\*/AE55\***

## Contact Installation Instructions

### Crimping Contacts

1. Select the appropriate crimp tool and ensure that the proper crimp head positioner is used.
2. Cycle the tool to be sure the indentors are open.
3. Determine the correct selector setting for the wire size from the data plate on the positioner (turret head assembly) and set the selector knob on the crimp tool to match.
4. Place the contact, mating end first, into the tool.
5. Insert the stripped wire into the hollow end of the contact. Be sure the wire is inserted as far as it will go.
6. Close the tool completely to crimp. Unless the tool is closed completely, the tool will not release the contact.
7. Remove the crimped contact from the tool. Check the inspection hole to verify that the wire is fully inserted.

### Insertion of Contacts

1. Before inserting the contacts, unscrew the accessories (clamps, backshells or adapters) from rear of plug or receptacle. Slide the hardware over the wire bundle in the proper order for reassembly after all the contacts are inserted.
2. To assist insertion of contacts, lubricate insulator (grommet) cavities with isopropyl alcohol. Alcohol will evaporate and will not leave a conductive film. **Caution: Never use any lubricant other than isopropyl alcohol.**

3. Place the correct insertion tool on the contact so that the wire runs along the groove in the tool. (Tool tip will butt against the shoulder.) Hold the plug or receptacle body firmly.
4. Beginning with a center cavity, insert the contact into the insulator with a slow, even pressure until the contact snaps into position. Make sure the contact and tool are held perpendicular to the face of the insert during the contact installation or the grommet could be damaged.
  - 4.1 If contacts are not inserted all the way prior to removing insertion tool, do not try to reinsert the insertion tool. Instead, remove the contact and try again; otherwise reinserting the insertion tool may damage the inside of the contact cavity.
5. Remove tool and check the face of the connector for proper contact installation. Proper installation may also be checked by pulling back lightly on the wire to make sure the contact is properly seated.

### Completion

After all the cavities have been filled, slide the hardware back into position on the connector and tighten.

### Extraction of Contacts (Rework)

1. Slide the hardware back over the wire bundle.
2. Select the appropriate tool. Place the wire into the extraction tool of the pin or socket.
3. Slowly slide the extraction tool down wire into the contact cavities until the tool tip bottoms against the contact shoulder, expanding the clip retaining tines. Hold the wire firmly in the tool and pull the wired contact and tool straight out of the rear of the insulator.

Size	Pin Contact	Socket Contact	Crimp Tool	Positioner	Die Set	Locator	I/R Tool
16S*	—	M39029/30-217	M22520/1-01	M22520/1-02 Blue	—	—	M81969/14-03
16	M39029/29-212	M39029/30-218	M22520/1-01	M22520/1-02 Blue	—	—	M81969/14-03
12	M39029/29-213	M39029/30-219	M22520/1-01	M22520/1-02 Yellow	—	—	M81969/14-04
8	M39029/29-214	M39029/30-220	M22520/23-01	—	M22520/23-02	M22520/23-09	M81969/14-06
4	M39029/29-215	M39029/30-221	M22520/23-01	—	M22520/23-04	M22520/23-11	M81969/14-07
0	M39029/29-216	M39029/30-222	M22520/23-01	—	M22520/23-05	M22520/23-13	M81969/14-08

I/R = Insertion/Removal

\* 16S socket contact is only used in shell sizes 8S, 10S, 10SL, 12S, 14S and 16S.



# MIL-DTL-5015 series III/AS50151

## Polarization, Insert Availability & Contact Information per MIL-STD-1651



### Polarization (Insert Clocking)

1. In the normal insert clocking position (position N), the insert centerline coincides with the centerline of the master keyway (key) of the shell:  $L = 0^\circ$ .
2. In the alternate clocking positions (W, X, Y and Z), the pin insert (viewing from mating side) is rotated clockwise relative to the centerline of the master keyway (key) of the shell.
3. The socket insert is rotated counter-clockwise.
4. Plugs have keyways; receptacles have keys.

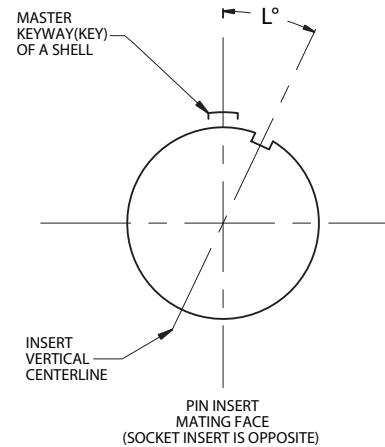

**Note:** Be careful with alternate positions. See table below for position availability on layouts of interest.

### Insert Availability, Contact Information and Clocking Positions

Shell Size & Insert Arrangement	Aero-Electric		Contacts				Service Rating	Contact Location	Insert Positions				
	Status		Total Number	Quantity by Size		"L" Degrees							
	QPL'd	Tooled		Qty	Size	N			W	X	Y	Z	
8S-1	Yes	Yes	1	1	16/16S**	A	All	0	—	—	—	—	
10S-2	Yes	Yes	1	1	16/16S**	A	All	0	—	—	—	—	
10SL-3***	Yes	Yes	3	3	16/16S**	A	All	0	—	—	—	—	
10SL-4	Yes	Yes	2	2	16/16S**	A	All	0	—	—	—	—	
12-5	Yes	Yes	1	1	12	D	All	0	—	—	—	—	
12S-3	Yes	Yes	2	2	16/16S**	A	All	0	70	145	215	290	
12S-4	Yes	Yes	1	1	16/16S**	D	All	0	—	—	—	—	
14-3	Yes	Yes	1	1	8	A	All	0	—	—	—	—	
14S-1*	Yes	Yes	3	3	16/16S**	A	All	0	—	—	—	—	
14S-2	Yes	Yes	4	4	16/16S**	Inst.	All	0	—	120	240	—	
14S-5	Yes	Yes	5	5	16/16S**	Inst.	All	0	—	110	—	—	
14S-6	Yes	Yes	6	6	16/16S**	Inst.	All	0	—	—	—	—	
14S-7	Yes	Yes	3	3	16/16S**	A	All	0	90	180	270	—	
14S-9*	Yes	Yes	2	2	16/16S**	A	All	0	70	145	215	290	
16-10	Yes	Yes	3	3	12	A	All	0	90	180	270	—	
16-11	Yes	Yes	2	2	12	A	All	0	35	110	250	325	
16-12	Yes	Yes	1	1	4	A	All	0	—	—	—	—	
16S-1	Yes	Yes	7	7	16/16S**	A	All	0	80	—	—	280	
16S-4	Yes	Yes	2	2	16/16S**	D	All	0	35	110	250	325	
16S-5*	Yes	Yes	3	3	16/16S**	A	All	0	70	145	215	290	
16S-8	Yes	Yes	5	5	16/16S**	A	All	0	—	170	265	—	

\* Inactive for new design

\*\* Pin contact is size 16, socket contact is size 16S

\*\*\* Service Rating = Inst. for classes KS and KT only.



**MIL-DTL-5015 series III/AS50151**  
**Insert Availability, Contact Information and Clocking**  
**per MIL-STD-1651**

**Insert Availability, Contact Information and Clocking Positions**

Shell Size & Insert Arrangement	Aero-Electric		Contacts				Service Rating	Contact Location	Insert Positions				
	Status		Total Number	Quantity by Size		Contact			"L" Degrees				
	QPL'd	Tooled		Qty	Size				N	W	X	Y	Z
18-1	Yes	Yes	10	4	16	A	B,C,F,G	0	70	145	215	290	
				6	16	Inst.	All others						
18-4	Yes	Yes	4	4	16	D	All	0	35	110	250	325	
18-5	Yes	Yes	3	1	16	D	All	0	80	110	250	280	
				2	12								
18-6	Yes	Yes	1	1	4	D	—	0	—	—	—	—	
18-8	Yes	Yes	8	7	16	A	All	0	70	—	—	290	
				1	12								
18-9	Yes	Yes	7	5	16	Inst.	All	0	80	110	250	280	
				2	12								
18-10*	Yes	Yes	4	4	12	A	All	0	—	120	240	—	
18-11	Yes	Yes	5	5	12	A	All	0	—	170	265	—	
18-12	Yes	Yes	6	6	16	A	All	0	80	—	—	280	
18-20*	Yes	Yes	5	5	16	A	All	0	90	180	270	—	
20-2	Yes	Yes	1	1	0	D	---	0	—	—	—	—	
20-3*	Yes	Yes	3	3	12	D	All	0	70	145	215	290	
20-4	Yes	Yes	4	4	12	D	All	0	45	110	250	—	
20-7	Yes	Yes	8	4	16	D	A,B,G,H	0	80	110	250	280	
				4	16	A	All others						
20-8	Yes	Yes	6	4	16	Inst.	All	0	80	110	250	280	
				2	8								
20-11*	Yes	Yes	13	13	16	Inst.	All	0	—	—	—	—	
20-14	Yes	No	5	3	12	A	All	0	80	110	250	280	
				2	8								
20-15	Yes	Yes	7	7	12	A	All	0	80	—	—	280	
20-16	Yes	Yes	9	7	16	A	All	0	80	110	250	280	
				2	12								
20-17	Yes	Yes	6	1	16	A	All	0	90	180	270	—	
				5	12								
20-18	Yes	Yes	9	6	16	A	All	0	35	110	250	325	
				3	12								
20-22	Yes	Yes	6	3	16	A	All	0	80	110	250	280	
				3	8								
20-24*	Yes	Yes	4	2	16	A	All	0	35	110	250	325	
				2	8								
20-27	Yes	Yes	14	14	16	A	All	0	35	110	250	325	
20-29	Yes	Yes	17	17	16	A	All	0	80	—	—	280	
20-33	Yes	Yes	11	11	16	A	All	0	—	—	—	—	
22-1*	Yes	Yes	2	2	8	D	All	0	35	110	250	325	

5015 S III

\* Inactive for new design

# MIL-DTL-5015 series III/AS50151

## Insert Availability, Contact Information and Clocking per MIL-STD-1651



### Insert Availability, Contact Information and Clocking Positions

Shell Size & Insert Arrangement	Aero-Electric		Contacts			Service Rating	Contact Location	Insert Positions				
	Status		Total Number	Quantity by Size				"L" Degrees				
	QPL'd	Tooled		Qty	Size			N	W	X	Y	Z
22-2	Yes	Yes	3	3	8	D	All	0	70	145	215	290
22-9	Yes	Yes	3	3	12	E	All	0	70	145	215	290
22-12	Yes	Yes	5	3	16	D	All	0	80	110	250	280
				2	8							
22-13*	Yes	Yes	5	1	16	D	E	0	35	110	250	325
				4	12	A	All others					
22-14**	Yes	Yes	19	19	16	A	All	0	80	110	250	280
22-18	Yes	Yes	8	3	16	A	C,D,E	0	80	110	250	280
				5	16	D	All others					
22-19	Yes	Yes	14	14	16	A	All	0	80	110	250	280
22-20*	Yes	Yes	9	9	16	A	All	0	35	110	250	325
22-22	Yes	Yes	4	4	8	A	All	0	—	110	250	—
22-23	Yes	Yes	8	1	12	D	H	0	35	—	250	—
				7	12	A	All others					
22-27	Yes	Yes	9	1	8	D	J	0	80	—	250	280
				8	16	A	All others					
22-33*	Yes	Yes	7	3	16	A	E,F,G	0	80	110	250	280
				4	16	D	All others					
24-2	Yes	Yes	7	7	12	D	All	0	80	—	—	280
24-4	Yes	Yes	4	3	16	D	All	0	80	110	250	280
				1	0							
24-6	Yes	Yes	8	3	12	D	A,G,H	0	80	110	250	280
				5	12	A	All others					
24-7	Yes	Yes	16	14	16	A	All	0	80	110	250	280
				2	12							
24-9*	Yes	Yes	2	2	4	A	All	0	35	110	250	325
24-10	Yes	Yes	7	7	8	A	All	0	80	—	—	280
24-11	Yes	Yes	9	6	12	A	All	0	35	110	250	325
				3	8							
24-12	Yes	Yes	5	3	12	A	All	0	80	110	250	280
				2	4							
24-20	Yes	Yes	11	9	16	D	All	0	80	110	250	280
				2	12							
24-21	Yes	No	10	9	16	D	All	0	80	110	250	280
				1	8							
24-22	Yes	Yes	4	4	8	D	All	0	45	110	250	—
24-27	Yes	Yes	7	7	16	E	All	0	80	—	—	280
24-28	Yes	Yes	24	24	16	Inst.	All	0	80	110	250	280

\* Inactive for new design

\*\* Alternate positions X, Y are cancelled after June 26, 1968.

5015 S III



**MIL-DTL-5015 series III/AS50151**  
**Insert Availability, Contact Information and Clocking**  
**per MIL-STD-1651**

**Insert Availability, Contact Information and Clocking Positions**

Shell Size & Insert Arrangement	Aero-Electric		Contacts				Service Rating	Contact Location	Insert Positions				
	Status		Total Number	Quantity by Size		Contact			"L" Degrees				
	QPL'd	Tooled		Qty	Size				N	W	X	Y	Z
28-1	Yes	Yes	9	2	12	D	A,E	0	80	110	250	280	
				4	12		A						B,D,F,H
				1	8		D						J
				2	8		A						G,C
28-2	Yes	Yes	14	12	16	D	All	0	35	110	250	325	
				2	12								
28-3	Yes	Yes	3	3	8	E	All	0	70	145	215	290	
28-5	Yes	Yes	5	2	16	D	All	0	35	110	250	325	
				1	12								
				2	4								
28-8	Yes	Yes	12	2	12	E	L,M	0	80	110	250	280	
				1	16	D	B						
				9	16	A	All others						
28-9	Yes	Yes	12	6	16	D	All	0	80	110	250	280	
				6	12								
28-11	Yes	Yes	22	18	16	A	All	0	80	110	250	280	
				4	12								
28-12	Yes	Yes	26	26	16	A	All	0	90	180	270	—	
28-15	Yes	Yes	35	35	16	A	All	0	80	110	250	280	
28-16*	Yes	Yes	20	20	16	A	All	0	80	110	250	280	
28-19	Yes	Yes	10	2	16	B	H,M	0	80	110	250	280	
				2	16	D	A,B						
				2	16	A	All others						
				4	12								
28-20	Yes	Yes	14	4	16	A	All	0	80	110	250	280	
				10	12								
28-21	Yes	Yes	37	37	16	A	All	0	80	110	250	280	
28-22	Yes	Yes	6	3	16	D	All	0	70	145	215	290	
				3	4								
32-1	Yes	Yes	5	1	12	E	A	0	80	110	250	280	
				2	12	D	D,C						
				2	0		B,E						
32-3	Yes	Yes	9	4	16	D	All	0	80	110	250	280	
				2	12								
				2	4								
				1	0								
32-5*	Yes	Yes	2	2	0	D	All	0	80	110	250	325	
32-6	Yes	Yes	23	16	16	A	All	0	80	110	250	280	
				2	12								
				3	8								
				2	4								

\* Inactive for new design

**MIL-DTL-5015 series III/AS50151**  
**Insert Availability, Contact Information and Clocking**  
**per MIL-STD-1651**



**Insert Availability, Contact Information and Clocking Positions**

Shell Size & Insert Arrangement	Aero-Electric		Contacts			Service Rating	Contact Location	Insert Positions				
	Status		Total Number	Quantity by Size				"L" Degrees				
	QPL'd	Tooled		Qty	Size			N	W	X	Y	Z
32-7	Yes	Yes	35	4	16	Inst.	A,B,h,j	0	80	125	235	280
				24	16							
				7	12							
32-8*	Yes	Yes	30	24	16	A	All	0	80	125	235	280
				6	12							
32-10*	Yes	Yes	7	2	16	E	A,F	0	80	110	250	280
				1	16	B	G					
				2	8	D	B,E					
				2	4	A	C,D					
32-15	Yes	Yes	8	6	12	D	All	0	35	110	250	280
				2	0							
32-17	Yes	Yes	4	4	4	D	All	0	45	110	250	---
32-22**	Yes	Yes	54	54	16	A	All	0	80	110	250	280
32-63	Yes	Yes	5	5	4	D	All	0	—	—	—	—
32-73	Yes	Yes	46	46	16	A	All	0	36	—	—	—
36-3	Yes	No	6	3	12	D	All	0	70	145	215	290
				3	0							
36-5	Yes	Yes	4	4	0	A	All	0	—	120	240	—
36-6	Yes	Yes	6	4	4	A	All	0	35	110	250	325
				2	0							
36-7	Yes	Yes	47	40	16	A	All	0	80	110	250	280
				7	12							
36-8	Yes	Yes	47	46	16	A	All	0	80	110	250	280
				1	12							
36-9	Yes	Yes	31	14	16	A	All	0	80	125	235	280
				14	12							
				2	8							
				1	4							
36-10	Yes	Yes	48	48	16	A	All	0	80	125	235	280
40-10	Yes	Yes	29	16	16	A	All	0	65	125	225	310
				9	8							
				4	4							
40-56	Yes	Yes	85	85	16	A	All	0	72	144	216	288

\* Inactive for new design

\*\* Alternate positions U (100 degrees) and V (260 degrees) are also available per MIL-STD-1651.

5015 S III

**Insert Arrangement Views**

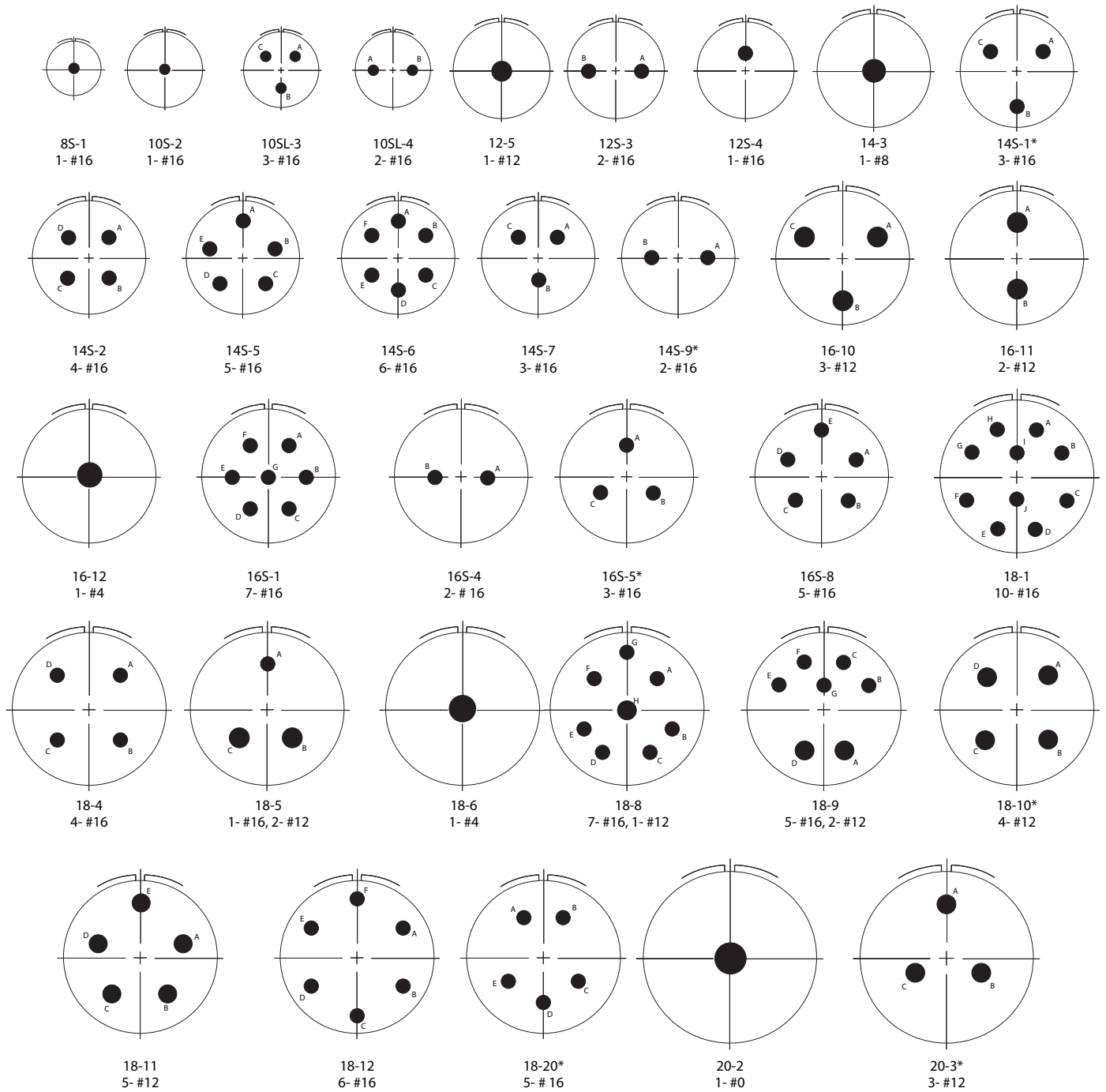

5015 S III

\* Inactive for new design

Insert Arrangement Views

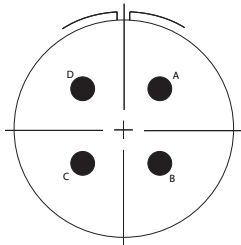

20-4  
4- #12

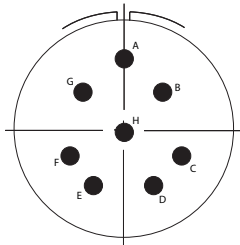

20-7  
8- #16

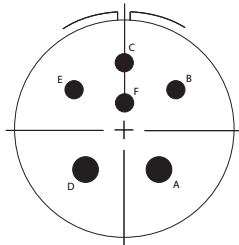

20-8  
4- #16, 2- #8

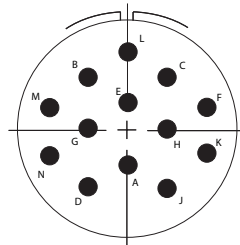

20-11\*  
13- #16

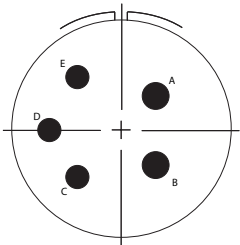

20-14  
3- #12, 2- #8

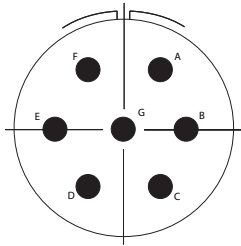

20-15  
7- #12

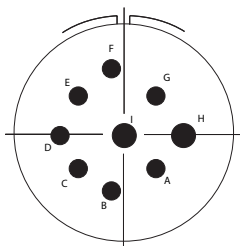

20-16  
7- #16, 2- #12

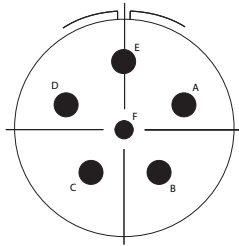

20-17  
1- #16, 5- #12

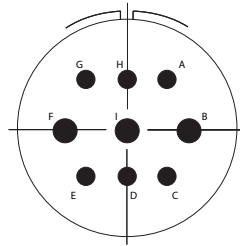

20-18  
6- #16, 3- #12

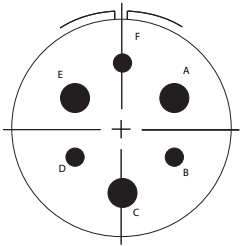

20-22  
3- #16, 3- #8

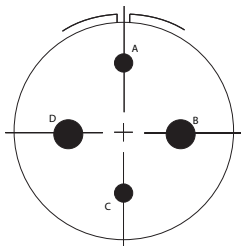

20-24\*  
2- #16, 2- #8

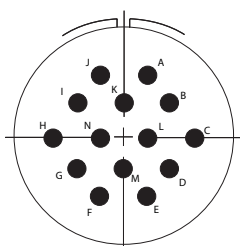

20-27  
14- #16

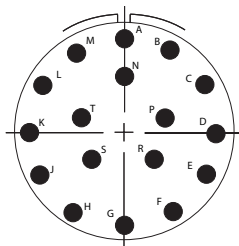

20-29  
17- #16

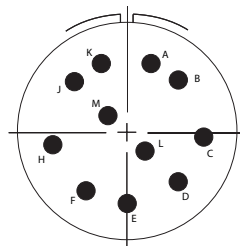

20-33  
11- #16

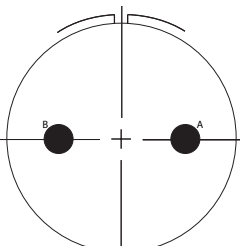

22-1\*  
2- #8

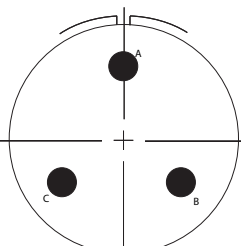

22-2  
3- #8

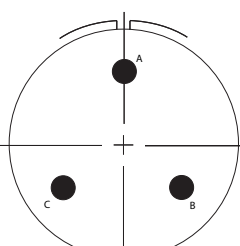

22-9  
3- #12

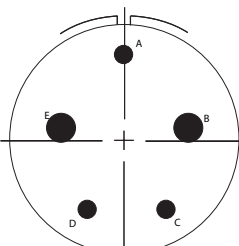

22-12  
3- #16, 2- #8

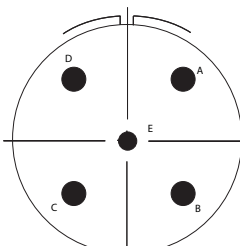

22-13\*  
1- #16, 4- #12

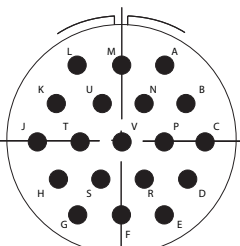

22-14  
19- #16

5015 S III

\* Inactive for new design



**Insert Arrangement Views**

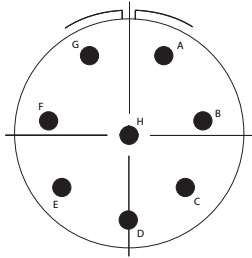

22-18  
8- #16

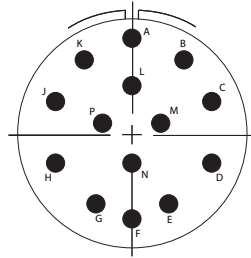

22-19  
14- #16

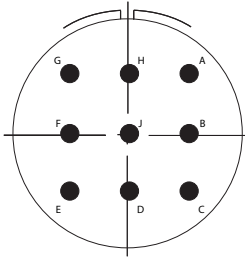

22-20\*  
9- #16

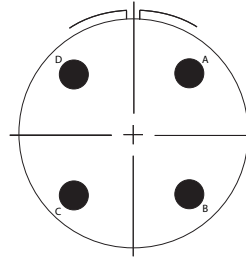

22-22  
4- #8

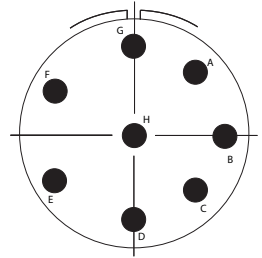

22-23  
8- #12

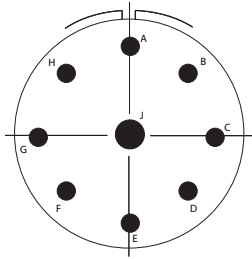

22-27  
1- #8, 8- #16

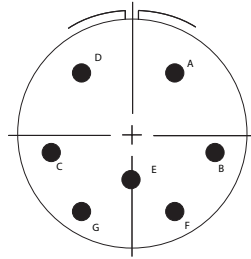

22-33\*  
7- #16

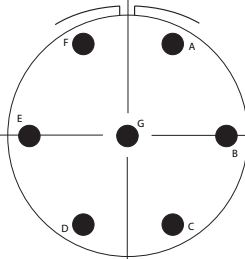

24-2  
7- #12

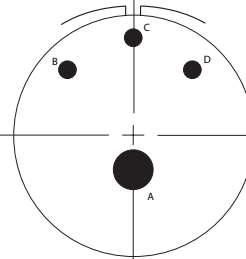

24-4  
3- #16, 1- #8

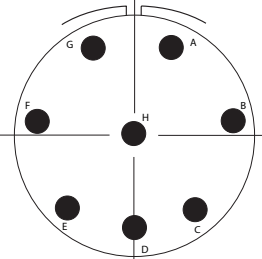

24-6  
8- #12

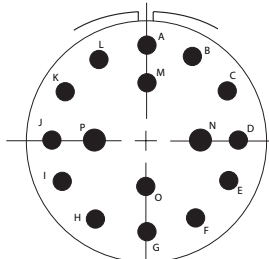

24-7  
14- #16, 2- #12

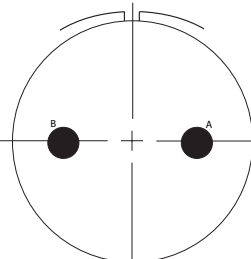

24-9\*  
2- #4

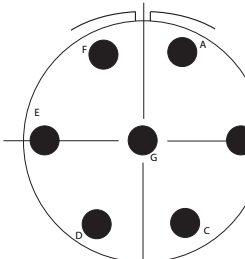

24-10  
7- #8

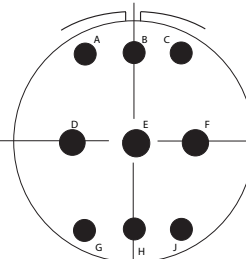

24-11  
6- #12, 3- #8

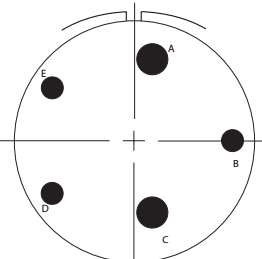

24-12  
3- #12, 2- #4

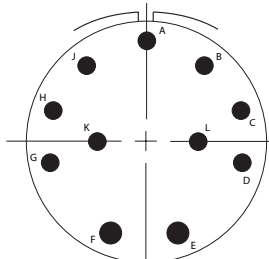

24-20  
9- #16, 2- #12

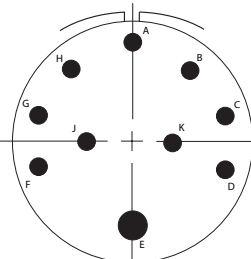

24-21  
9- #16, 1- #8

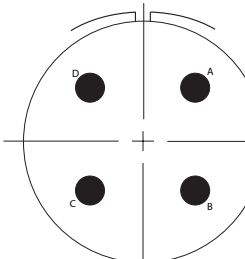

24-22  
4- #8

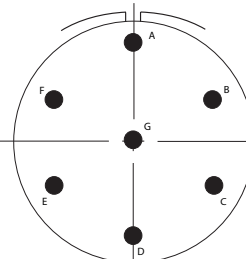

24-27  
7- #16

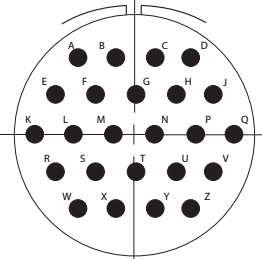

24-28  
24- #16

5015 S III

\* Inactive for new design



Insert Arrangement Views

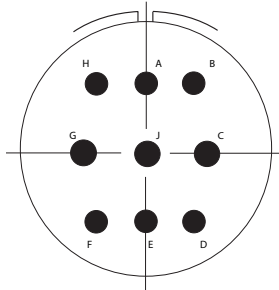

28-1  
6- #12, 3- #8

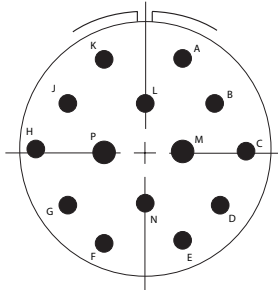

28-2  
12- #16, 2- #12

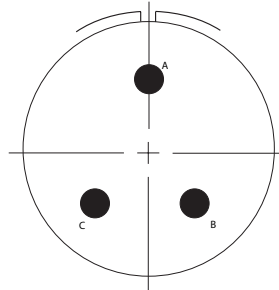

28-3  
3- #8

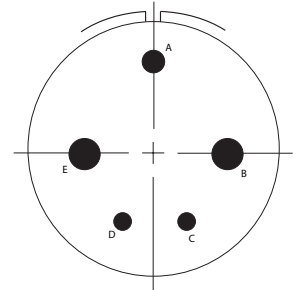

28-5  
2- #16, 1- #12, 2- #4

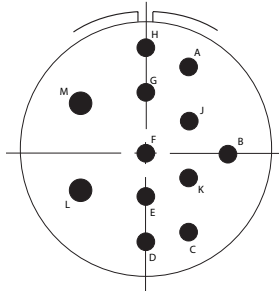

28-8  
2- #12, 10- #16

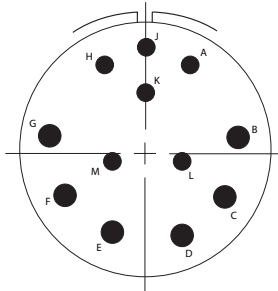

28-9  
6- #16, 6- #12

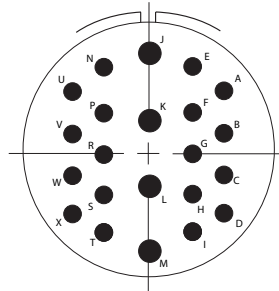

28-11  
18- #16, 4- #12

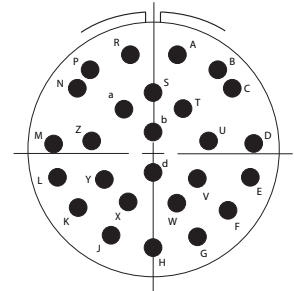

28-12  
26- #16

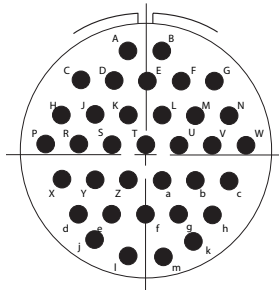

28-15  
35- #16

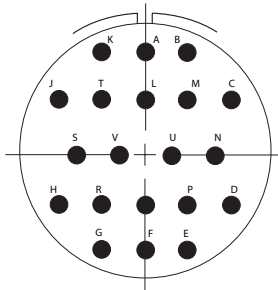

28-16\*  
20- #16

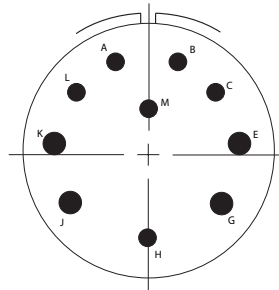

28-19  
6- #16, 4- #12

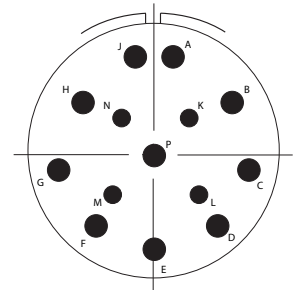

28-20  
4- #16, 10- #12

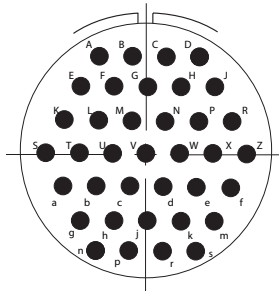

28-21  
37- #16

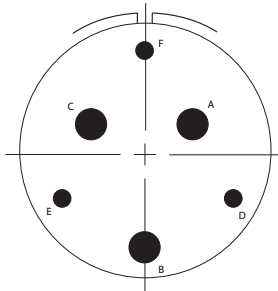

28-22  
3- #16, 3- #4

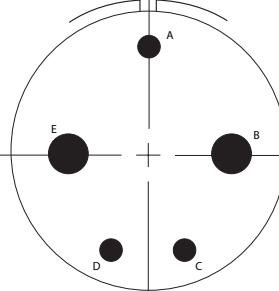

32-1  
3- #12, 2- #0

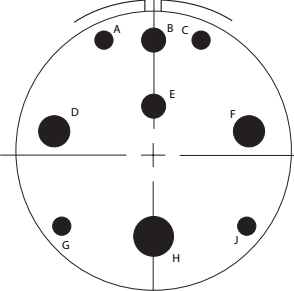

32-3  
4- #16, 2- #12,  
2- #4, 1- #0

\* Inactive for new design

5015 S III

**Insert Arrangement Views**

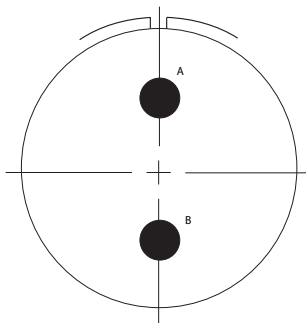

32-5\*  
2- #0

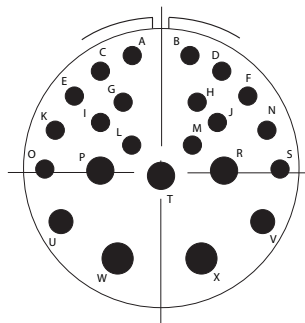

32-6  
16- #16, 2- #12,  
3- #8, 2- #4

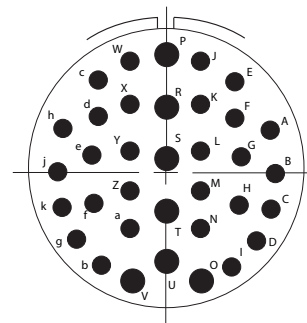

32-7  
28- #16, 7- #12

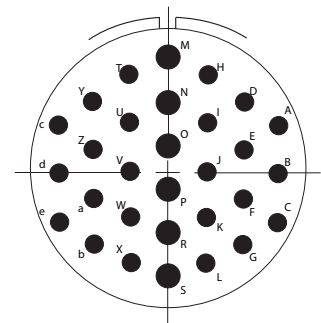

32-8\*  
24- #16, 6- #12

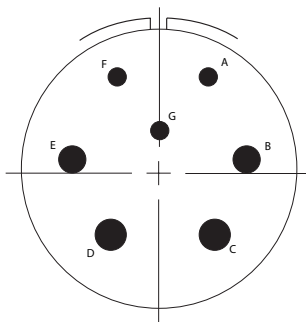

32-10\*  
3- #16, 2- #8,  
2- #4

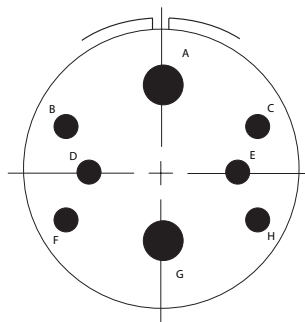

32-15  
6- #12, 2- #0

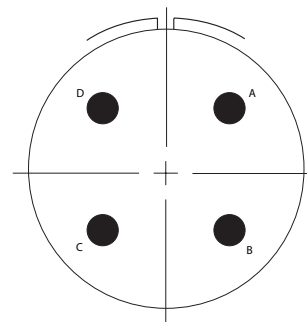

32-17  
4- #4

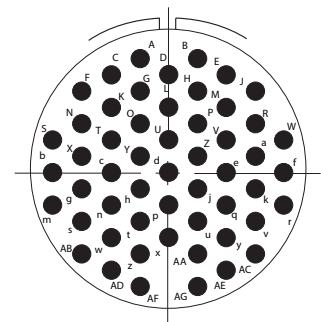

32-22  
54- #16

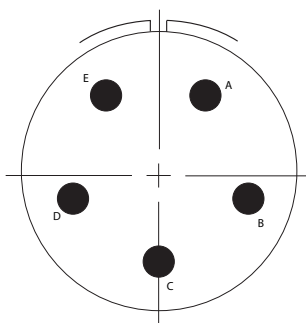

32-63  
5- #4

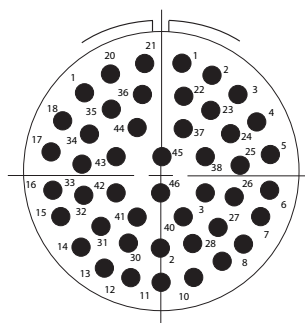

32-73  
46- #16

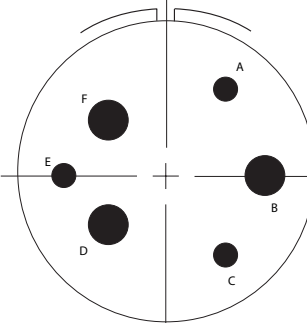

36-3  
3- #12, 3- #0

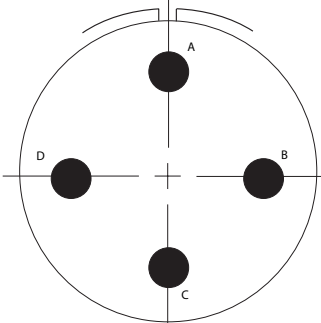

36-5  
4- #0

5015 S III

\* Inactive for new design

# MIL-STD-1651

## Insert Arrangements (Pin Front View) for MIL-DTL-5015 Connectors



### Insert Arrangement Views

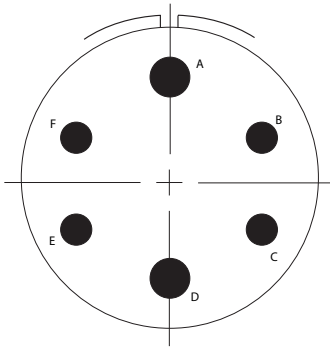

36-6  
4- #4, 2- #0

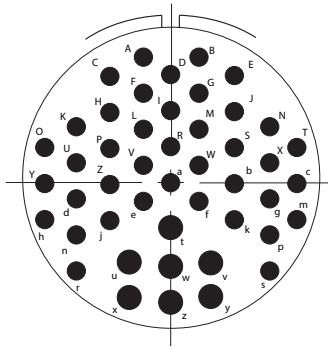

36-7  
40- #16, 7- #12

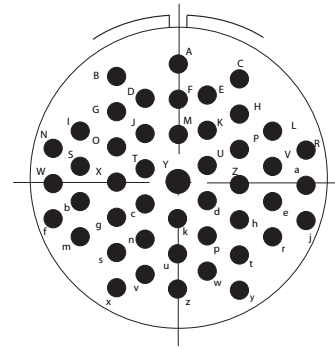

36-8  
46- #16, 1- #12

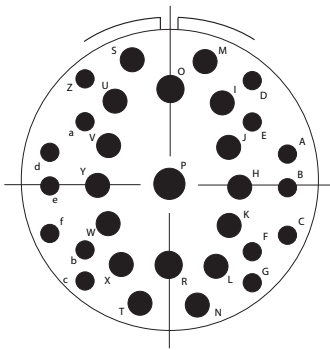

36-9  
14- #16, 14- #12,  
2- #8, 1- #4

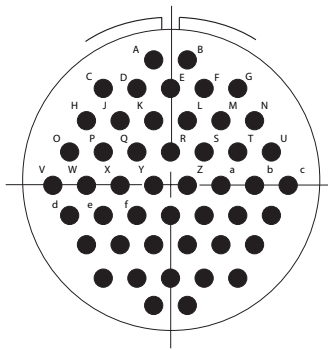

36-10  
48- #16

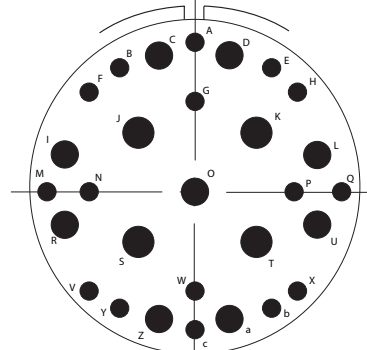

40-10  
16- #16, 9- #8,  
4- #4

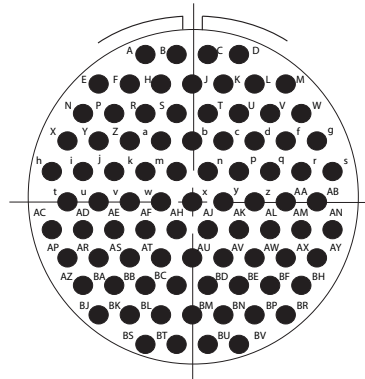

40-56  
85- #16

5015 S III



**MIL-DTL-5015 Series III**  
**Integrated Rear Banding Platform**  
**Part Number Development**

**Part Number Configuration**

<b>Aero Prefix</b>	<b>AE05-</b>	<b>440-</b>	<b>L</b>	<b>24-</b>	<b>10</b>	<b>P</b>	<b>W</b>
<b>Shell Type</b> <b>440</b> = Wall Mount Receptacle (Ref: MS3450) <b>442</b> = Jam Nut Receptacle (Ref: MS3454) <b>443</b> = Straight Plug (Ref: MS3456)							
<b>Material &amp; Finish</b> <b>A</b> = Aluminum Shell, Black Anodized Finish <b>KS</b> = Stainless Shell, Passivated Finish, Firewall (RoHS) <b>KT</b> = Ferrous Alloy Shell, Olive Drab Cadmium Finish, Firewall <b>L</b> = Aluminum Shell, Electroless Nickel Finish <b>LS</b> = Stainless Steel, Passivated Finish (RoHS) <b>W</b> = Aluminum Shell, Olive Drab Cadmium Finish <b>BN</b> = Aluminum Shell, black nickel finish (RoHS) <b>Z</b> = Aluminum shell, Black Zinc Nickel finish (RoHS)							
<b>Shell Size</b> <b>8S, 10S, 10SL, 12, 12S, 14, 14S, 16, 16S, 18, 20, 22, 24, 28, 32, 36, 40</b>							
<b>Insert Arrangement</b> Per MIL-STD-1651							
<b>Contact Style</b> <b>P</b> = Pin <b>S</b> = Socket							
<b>Polarization (Keying)</b> <b>N</b> = Normal = Blank <b>Alternative Polarization</b> = W, X, Y and Z							

INTEGRATED REAR

# MIL-DTL-5015 Series III Integrated Rear Banding Platform Wall Mount Receptacle (MS3450)



## AE05-440 Receptacle Connector, Wall Mount, with integrated Rear Banding Platform

INTEGRATED REAR

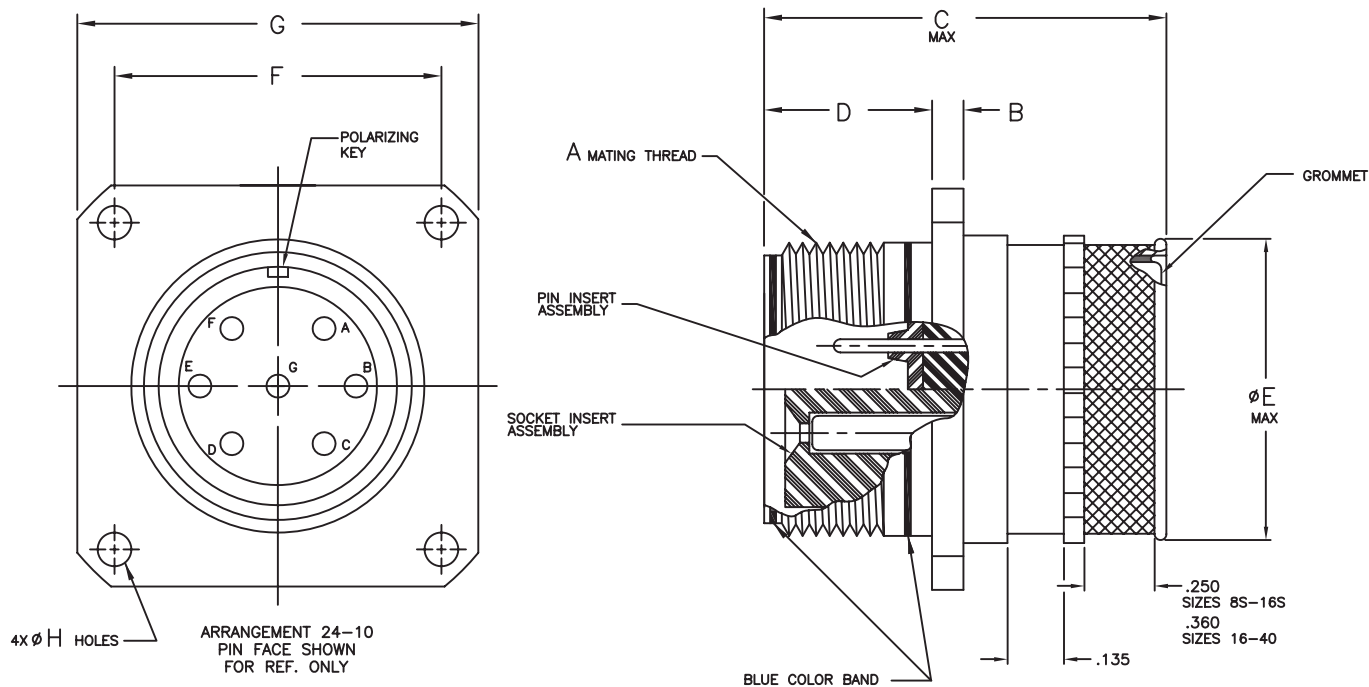

SHELL SIZE	A COUPLING THREAD CLASS 2A	B ±.015	C MAX	D +.031 -.000	Ø E MAX	F (T.P.)	G ±.031	ØH +.010 -.005	
								ALUMINUM	STEEL
8S	.500-28 UNEF	.083	2.031	.562	.505	.594	.875	.120	.150
10S	.625-24 UNEF	.083	2.031	.562	.632	.719	1.000	.120	.150
10SL	.625-24 UNEF	.083	2.031	.562	.632	.719	1.000	.120	.150
12	.750-20 UNEF	.083	2.125	.750	.755	.812	1.094	.120	.150
12S	.750-20 UNEF	.083	2.031	.562	.755	.812	1.094	.120	.150
14	.875-20 UNEF	.083	2.125	.750	.880	.906	1.188	.120	.150
14S	.875-20 UNEF	.083	2.031	.562	.880	.906	1.188	.120	.150
16	1.000-20 UNEF	.083	2.500	.750	1.005	.969	1.281	.120	.150
16S	1.000-20 UNEF	.083	2.031	.562	1.005	.969	1.281	.120	.150
18	1.125-16 UNEF	.125	2.500	.750	1.065	1.062	1.375	.120	.177
20	1.250-18 UNEF	.125	2.500	.750	1.190	1.156	1.500	.120	.177
22	1.375-18 UNEF	.125	2.500	.750	1.315	1.250	1.625	.120	.177
24	1.500-18 UNEF	.125	2.500	.812	1.440	1.375	1.750	.147	.177
28	1.750-18 UNS	.125	2.500	.812	1.750	1.562	2.000	.147	.177
32	2.000-18 UNS	.125	2.500	.875	2.000	1.750	2.250	.173	.209
36	2.250-16 UN	.125	2.500	.875	2.250	1.938	2.500	.173	.209
40	2.500-16 UN	.125	2.500	.875	2.500	2.188	2.750	.173	.209



**MIL-DTL-5015 Series III**  
**Integrated Rear Banding Platform**  
**Jam Nut Receptacle (MS3454)**

**AE05-442 Receptacle Connector, Jam Nut, with integrated rear banding platform**

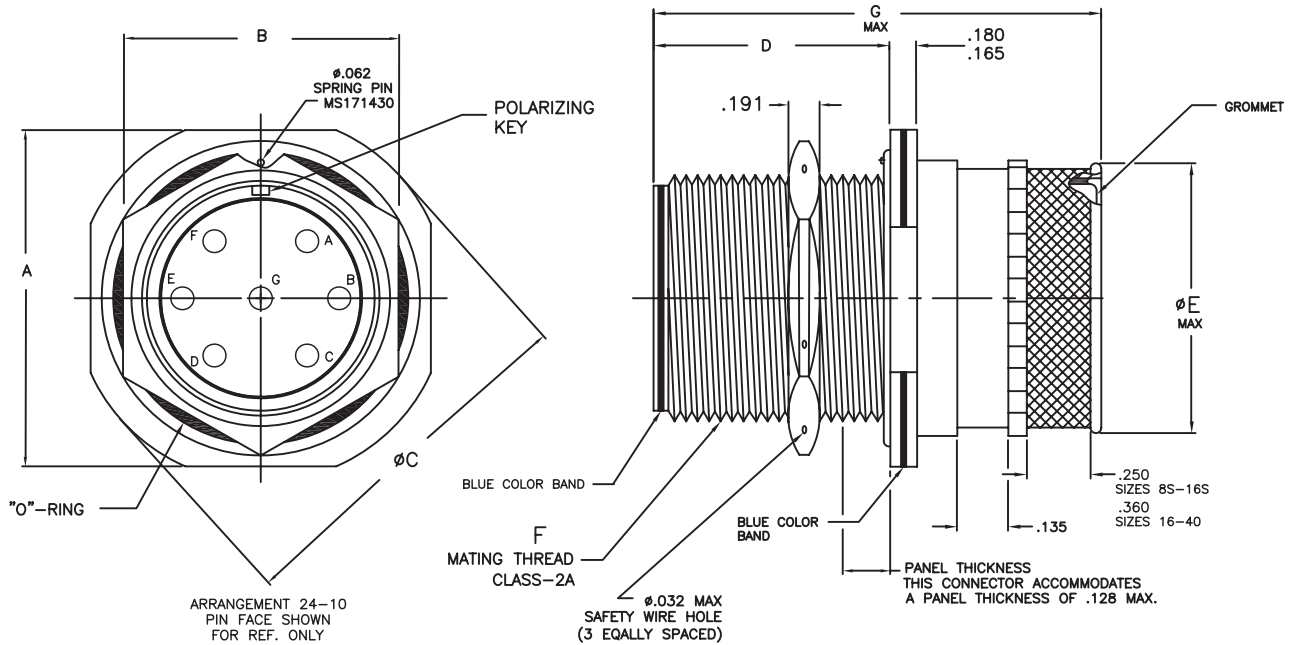

INTEGRATED REAR

SHELL SIZE	A	B ±.010	Ø C	D	Ø E MAX	F THREAD-2A	G MAX
8S	1.187	.687	1.272	.720	.505	.500-28 UNEF	2.031
10S	1.312	.812	1.397	.720	.632	.625-24 UNEF	2.031
10SL	1.312	.812	1.397	.720	.632	.625-24 UNEF	2.031
12	1.437	.937	1.522	.970	.755	.750-20 UNEF	2.125
12S	1.562	.937	1.522	.720	.755	.750-20 UNEF	2.031
14	1.562	1.125	1.647	.970	.880	.875-20 UNEF	2.125
14S	1.562	1.125	1.647	.720	.880	.875-20 UNEF	2.031
16	1.687	1.250	1.772	.970	1.005	1.000-20 UNEF	2.500
16S	1.687	1.250	1.772	.720	1.005	1.000-20 UNEF	2.031
18	1.812	1.375	1.897	.970	1.065	1.125-18 UNEF	2.500
20	1.937	1.500	2.022	.970	1.190	1.250-18 UNEF	2.500
22	2.156	1.625	2.241	.970	1.315	1.375-18 UNEF	2.500
24	2.281	1.750	2.366	.970	1.440	1.500-18 UNEF	2.500
28	2.531	2.000	2.616	.970	1.750	1.750-18 UNS	2.500
32	2.781	2.375	2.866	.970	2.000	2.000-18 UNS	2.500
36	3.031	2.625	3.116	.970	2.250	2.250-16 UN	2.500
40	3.281	2.875	3.366	.970	2.500	2.500-16 UN	2.500

**MIL-DTL-5015 Series III**  
**Integrated Rear Banding Platform**  
**Straight Plug (MS3456)**



**AE05-443 Straight Plug Connector, with integrated Rear Banding Platform**

INTEGRATED REAR

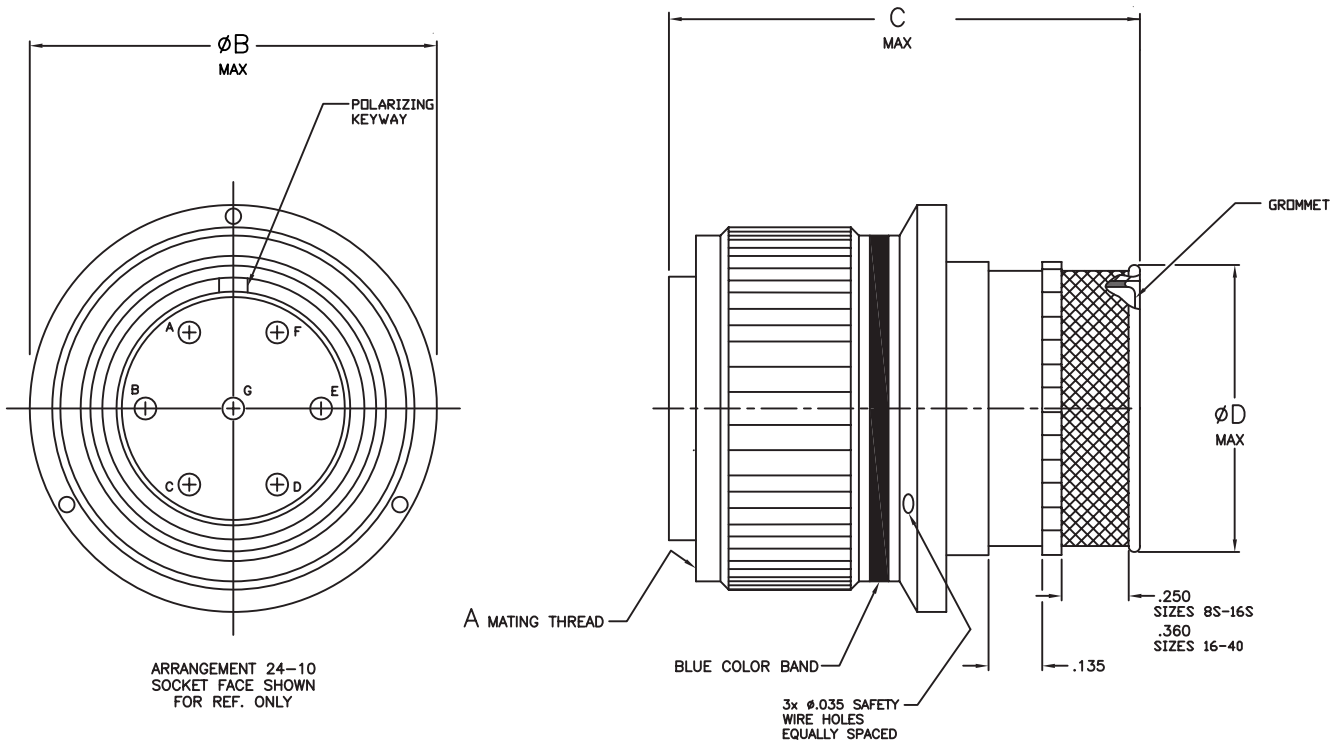

SHELL SIZE	A COUPLING THREAD CLASS 2B	ØB MAX	C MAX	ØD MAX
8S	.500-28 UNEF	.844	2.031	.505
10S	.625-24 UNEF	.969	2.031	.632
10SL	.625-24 UNEF	.969	2.031	.632
12	.750-20 UNEF	1.062	2.125	.755
12S	.750-20 UNEF	1.062	2.031	.755
14	.875-20 UNEF	1.156	2.125	.880
14S	.875-20 UNEF	1.156	2.031	.880
16	1.000-20 UNEF	1.250	2.500	1.005
16S	1.000-20 UNEF	1.250	2.031	1.005
18	1.125-18 UNEF	1.344	2.500	1.065
20	1.250-18 UNEF	1.469	2.500	1.190
22	1.375-18 UNEF	1.594	2.500	1.315
24	1.500-18 UNEF	1.719	2.500	1.440
28	1.750-18 UNS	1.969	2.500	1.750
32	2.000-18 UNS	2.219	2.500	2.000
36	2.250-16 UN	2.469	2.500	2.250
40	2.500-16 UN	2.719	2.500	2.500



# MIL-DTL-26482 Series II Integrated Rear Banding Platform Part Number Configuration

## Part Number Configuration

Aero Prefix	AE15-	469-	L	18-	8	P	W
<b>Shell Type</b> 469 = Rear, narrow flange (Ref: MS3470) 470 = Rear, cable connecting receptacle (Ref: MS3471) 471 = Rear, wide flange receptacle (Ref: MS3472) 472 = Rear, jam nut receptacle (Ref: MS3474) 473 = Rear, RFI plug (Ref: MS3475) 474 = Rear, straight plug (Ref: MS3476)							
<b>Material Finish</b> L = Aluminum Shell, Electroless Nickel Finish W = Aluminum Shell, Olive Drab Cadmium Finish BN = Aluminum Shell, black nickel finish (RoHS)(not available for AE15-473 (ref: MS3475)) Z = Aluminum shell, Black Zinc Nickel finish (RoHS), (not available for AE15-473, ref: MS3475)							
<b>Shell Size</b> 8, 10, 12, 14, 16, 18, 20, 22, 24							
<b>Insert Arrangement</b> Per MIL -STD-1669							
<b>Contact Style</b> P = Pin S = Socket							
<b>Polarization (Keying)</b> Normal = Blank <b>Alternative Polarization</b> = W, X, Y and Z							

INTEGRATED REAR



**MIL-DTL-26482 Series II**  
**Integrated Rear Banding Platform**  
**Narrow Flange Receptacle (MS3470)**



**AE15-469 Receptacle Connector, Narrow Flange, with integrated Rear Banding Platform**

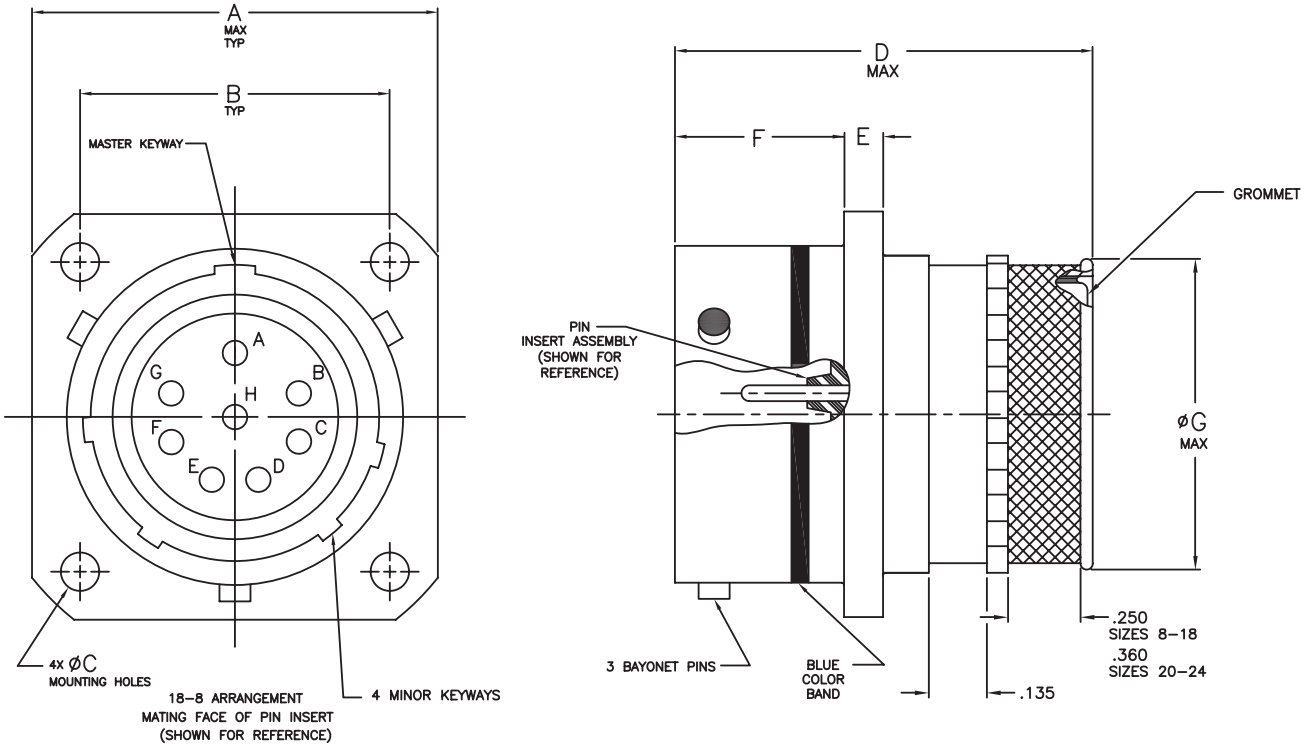

INTEGRATED REAR

SHELL SIZE	A MAX	B	ØC	D MAX	E	F	ØG MAX
8	.828	.599/.589	.120	1.410	.078/.046	.462/.431	.505
10	.964	.724/.714	.120	1.410	.078/.046	.462/.431	.632
12	1.047	.817/.807	.120	1.410	.078/.046	.462/.431	.755
14	1.141	.911/.901	.120	1.410	.078/.046	.462/.431	.880
16	1.234	.974/.964	.120	1.410	.078/.046	.462/.431	1.005
18	1.328	1.067/1.057	.120	1.410	.078/.046	.462/.431	1.065
20	1.453	1.161/1.151	.120	1.475	.110/.078	.587/.556	1.190
22	1.578	1.255/1.245	.120	1.475	.110/.078	.587/.556	1.315
24	1.703	1.380/1.370	.147	1.475	.110/.078	.587/.556	1.440



**MIL-DTL-26482 Series II**  
**Integrated Rear Banding Platform**  
**Cable Connecting Receptacle (MS3471)**

AE15-470 Receptacle Connector, Cable Connecting, with integrated rear banding platform

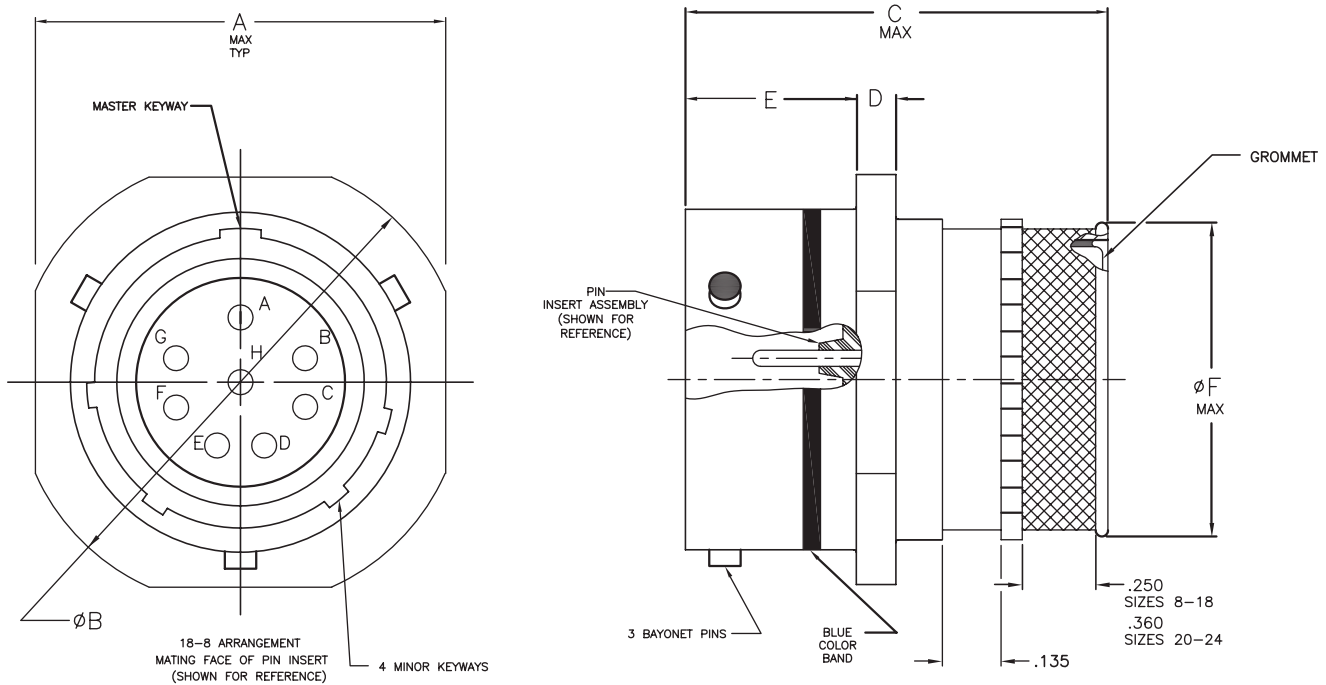

INTEGRATED REAR

SHELL SIZE	A MAX	ØB	C MAX	D	E	ØF MAX
8	.828	.958/.918	1.410	.078/.046	.462/.431	.505
10	.964	1.082/1.042	1.410	.078/.046	.462/.431	.632
12	1.047	1.176/1.136	1.410	.078/.046	.462/.431	.755
14	1.141	1.270/1.230	1.410	.078/.046	.462/.431	.880
16	1.234	1.364/1.324	1.410	.078/.046	.462/.431	1.005
18	1.328	1.458/1.418	1.410	.078/.046	.462/.431	1.065
20	1.453	1.582/1.542	1.475	.110/.078	.587/.556	1.190
22	1.578	1.708/1.668	1.475	.110/.078	.587/.556	1.315
24	1.703	1.832/1.792	1.475	.110/.078	.620/.589	1.440

**MIL-DTL-26482 Series II**  
**Integrated Rear Banding Platform**  
**Wide Flange Receptacle (MS3472)**



**AE15-471 Receptacle Connector, Wide Flange, with integrated Rear Banding Platform**

INTEGRATED REAR

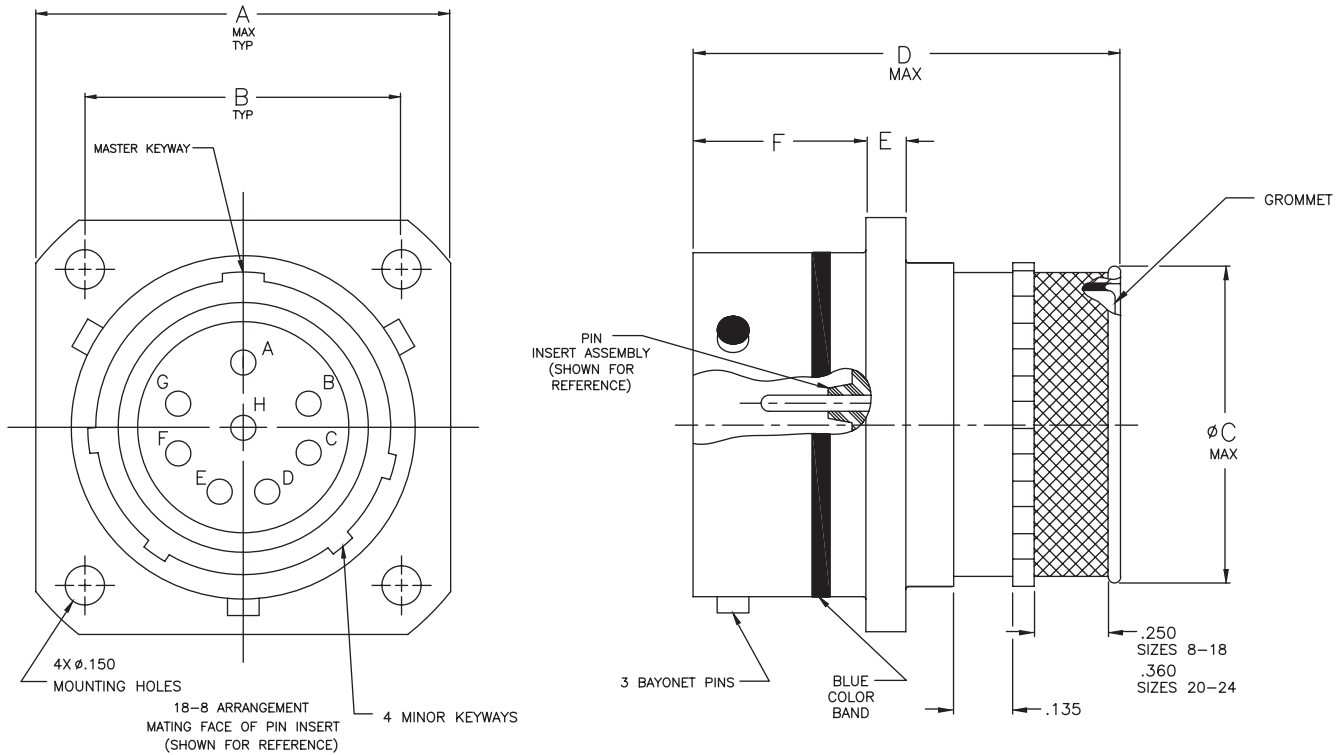

SHELL SIZE	A MAX	B	$\phi$ C MAX	D MAX	E	F MAX
8	1.065	.734	.505	1.410	.078/.046	.493/.462
10	1.141	.812	.632	1.410	.078/.046	.493/.462
12	1.266	.938	.755	1.410	.078/.046	.493/.462
14	1.360	1.031	.880	1.410	.078/.046	.493/.462
16	1.453	1.125	1.005	1.410	.078/.046	.493/.462
18	1.532	1.203	1.065	1.410	.078/.046	.493/.462
20	1.688	1.297	1.190	1.475	.110/.078	.587/.556
22	1.766	1.375	1.315	1.475	.110/.078	.587/.556
24	1.891	1.500	1.440	1.475	.110/.078	.587/.556



**MIL-DTL-26482 Series II**  
**Integrated Rear Banding Platform**  
**Jam Nut Receptacle (MS3474)**

**AE15-472 Receptacle Connector, Jam Nut, with integrated Rear Banding Platform**

INTEGRATED REAR

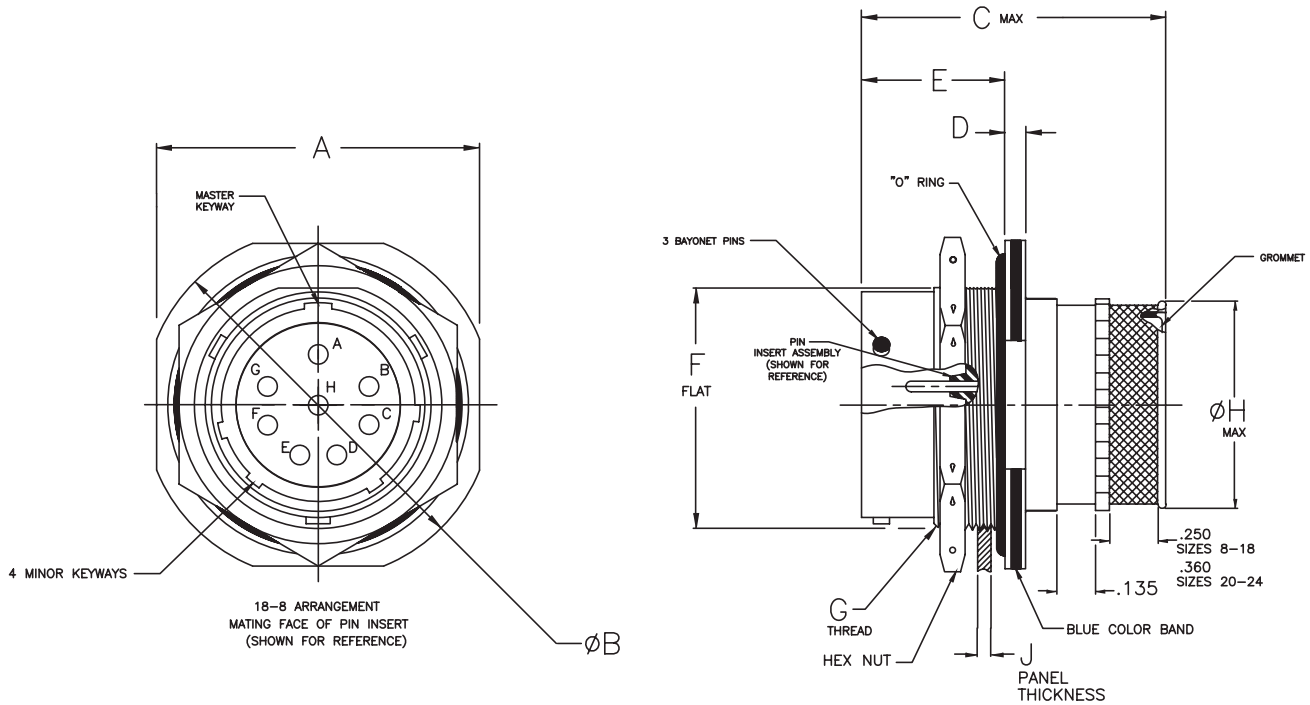

SHELL SIZE	A	ØB	C MAX	D	E	F FLAT	G THREAD-2A	ØH MAX	J RECOMMENDED PANEL THICKNESS
8	.954/.923	1.078/1.047	1.410	.113/.086	.707/.658	.525	.562-24	.505	.187/.062
10	1.078/1.047	1.203/1.172	1.410	.113/.086	.707/.658	.650	.687-24	.632	.187/.062
12	1.266/1.235	1.391/1.360	1.410	.113/.086	.707/.658	.813	.875-40	.755	.187/.062
14	1.391/1.360	1.516/1.485	1.410	.113/.086	.707/.658	.937	1.000-20	.880	.187/.062
16	1.516/1.485	1.641/1.610	1.410	.113/.086	.707/.658	1.061	1.125-18	1.005	.187/.062
18	1.641/1.610	1.766/1.735	1.410	.113/.086	.707/.658	1.186	1.250-18	1.065	.187/.062
20	1.828/1.797	1.954/1.923	1.475	.148/.096	.772/.721	1.311	1.375-18	1.190	.250/.062
22	1.954/1.923	2.078/2.047	1.475	.148/.096	.772/.721	1.436	1.500-18	1.315	.250/.062
24	2.078/2.047	2.203/2.172	1.475	.148/.096	.772/.721	1.561	1.625-18	1.440	.250/.062

**MIL-DTL-26482 Series II**  
**Integrated Rear Banding Platform**  
**RFI Grounding Plug (MS3475)**



**AE15-473 Plug Connector, RFI, with integrated Rear Banding Platform**

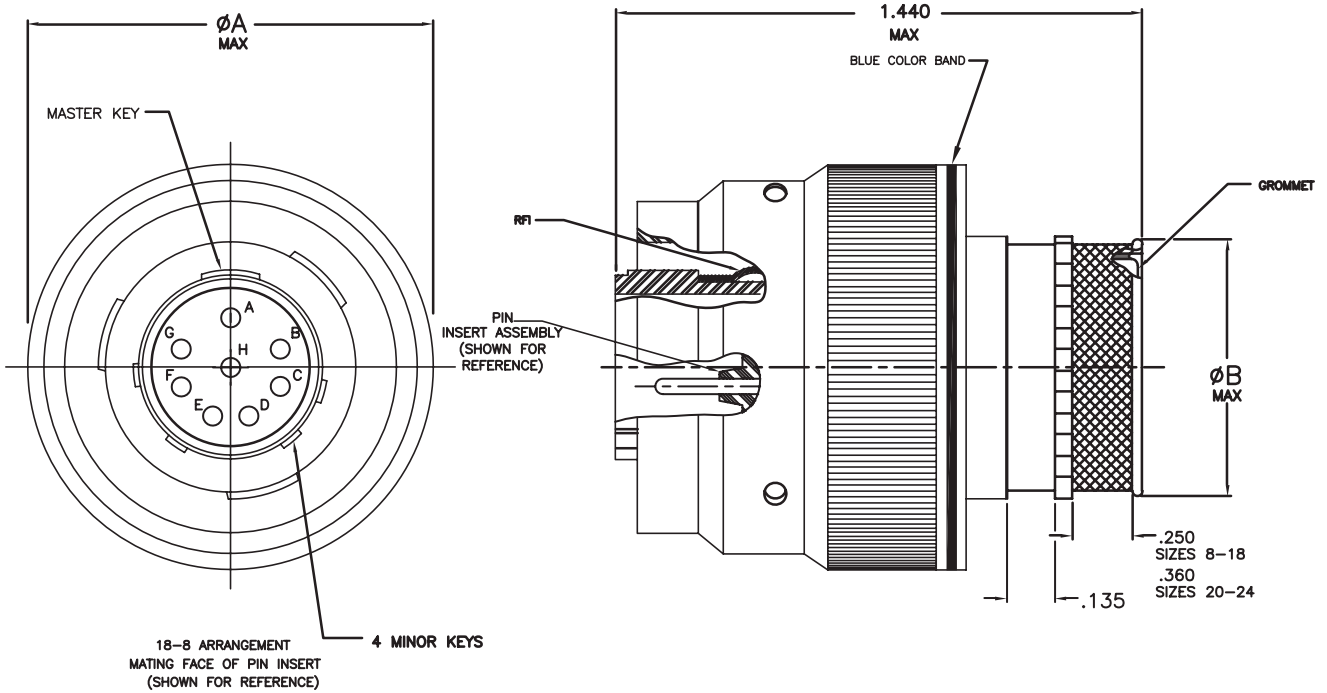

INTEGRATED REAR

SHELL SIZE	$\phi A$ MAX	$\phi B$ MAX
8	.782	.505
10	.926	.632
12	1.043	.755
14	1.183	.880
16	1.305	1.005
18	1.391	1.065
20	1.631	1.190
22	1.656	1.315
24	1.777	1.440

**AE15-474 Plug Connector, Straight, with integrated Rear Banding Platform**

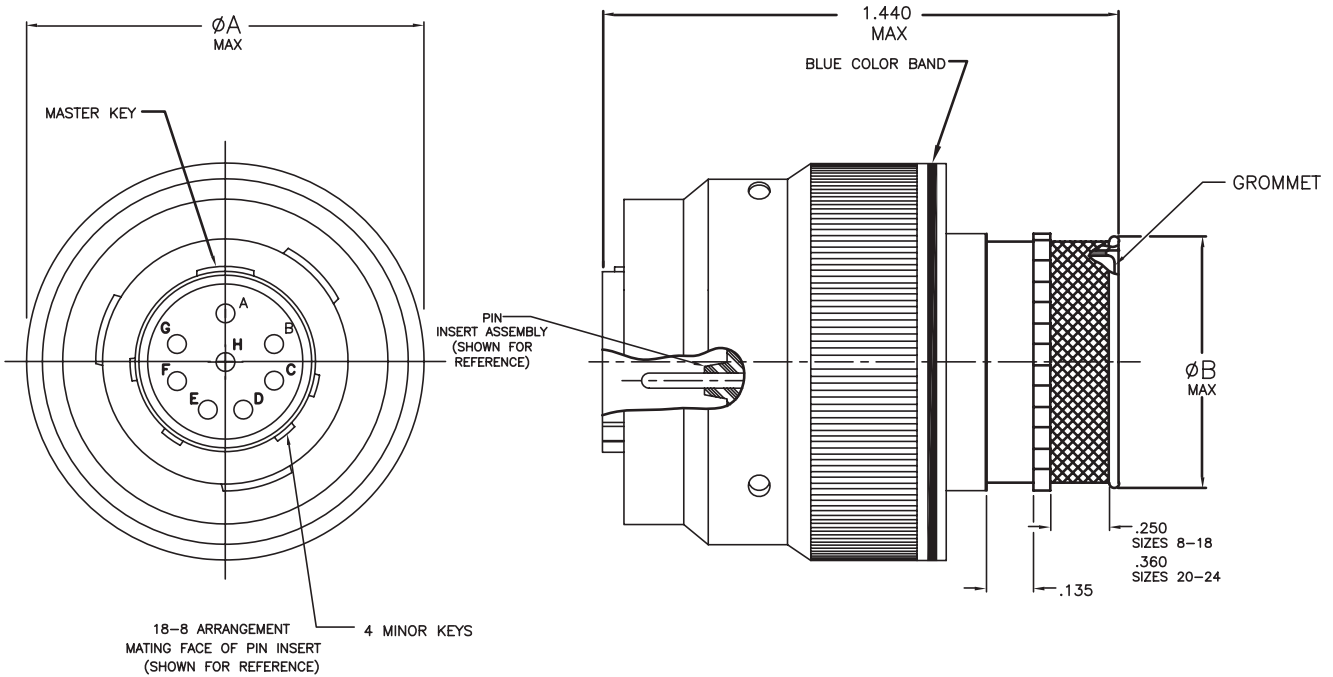

INTEGRATED REAR

SHELL SIZE	$\phi A$ MAX	$\phi B$ MAX
8	.782	.505
10	.926	.632
12	1.043	.755
14	1.183	.880
16	1.305	1.005
18	1.391	1.065
20	1.631	1.190
22	1.656	1.315
24	1.777	1.440

# MIL-DTL-38999 Series I Integrated Rear Banding Platform Part Number Development



## Part Number Configuration

Aero Prefix	AE45-	475-	T	15	B	15	P	A
<b>Shell Type</b>								
475 = Front, wall mount (Ref: MS27466)								
476 = Plug Connector, RFI (Ref: MS27467)								
477 = Jam Nut Connector (Ref: MS27468)								
478 = Rear, wall mount (Ref: MS27656)								
<b>Class</b>								
T for reference only								
<b>Shell Size</b>								
9, 11, 13, 15, 17, 19, 21, 23, 25								
<b>Material Finish</b>								
A = Aluminum, Bright Cadmium								
B = Aluminum, Cadmium/Olive Drab								
F = Aluminum, Electroless Nickel								
S = Stainless Steel, Passivated (RoHS)								
RN = Aluminum Shell, Electroless nickel finish (RoHS)								
<b>Insert Arrangement</b>								
Per MIL-STD-1560								
<b>Contact Style</b>								
P = Pin								
S = Socket								
<b>Polarization (Keying)</b>								
Normal = Blank								
Alternative Polarization = A, B, C & D								

INTEGRATED REAR

**AE45-475 Front Wall Mount Receptacle with integrated Rear Banding Platform**

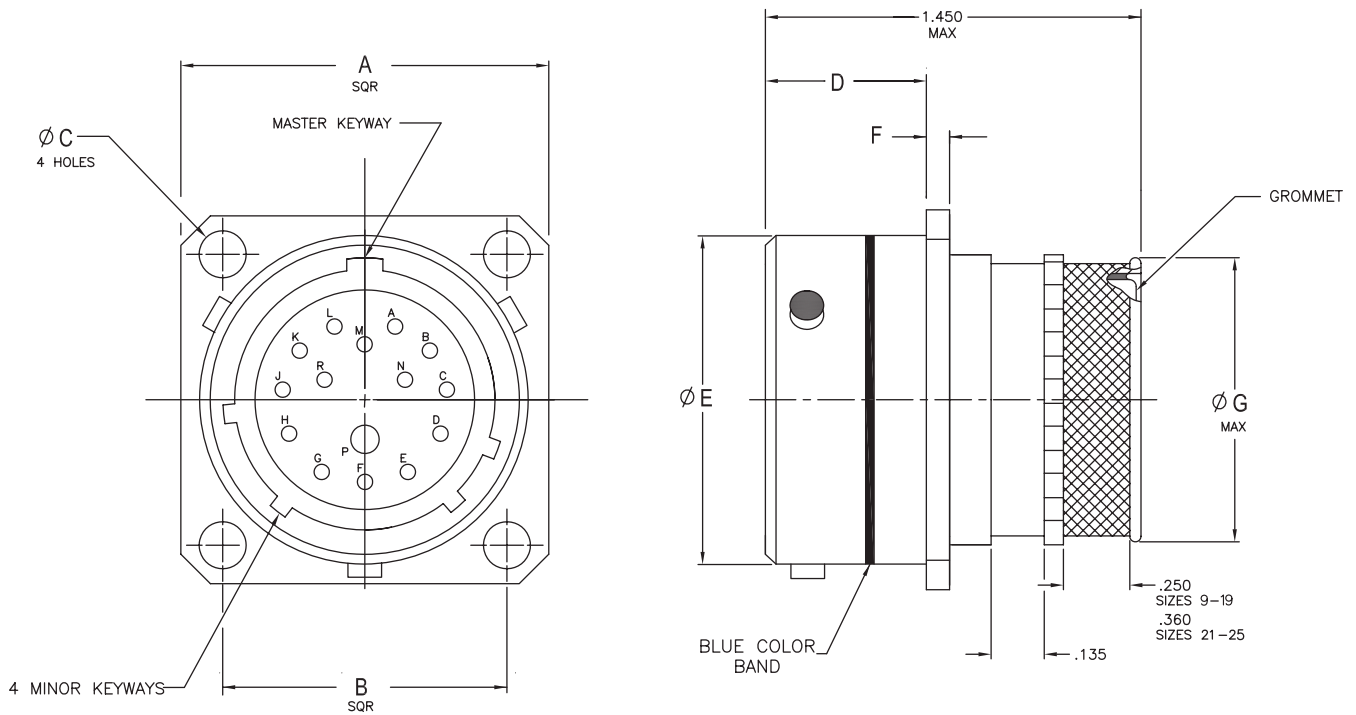

INTEGRATED REAR

SHELL SIZE	A	B	ØC	D	ØE	F	ØG MAX
	±.020	BASIC	+0.010 -.005	+0.000 -.005	+0.001 -.005	+0.015 -.000	
9	.938	.719	.128	.820	.572	.085	.453
11	1.031	.812	.128	.820	.700	.085	.571
13	1.125	.906	.128	.820	.850	.085	.690
15	1.219	.969	.128	.820	.975	.085	.847
17	1.312	1.062	.128	.820	1.100	.085	.965
19	1.438	1.156	.128	.820	1.207	.085	1.083
21	1.562	1.250	.128	.790	1.332	.115	1.201
23	1.688	1.375	.147	.790	1.457	.115	1.319
25	1.812	1.500	.147	.790	1.582	.115	1.447



**MIL-DTL-38999 Series I**  
**Integrated Rear Banding Platform**  
**(MS27467)**



**AE45-476 Plug Connector, RFI, with integrated Rear Banding Platform**

INTEGRATED REAR

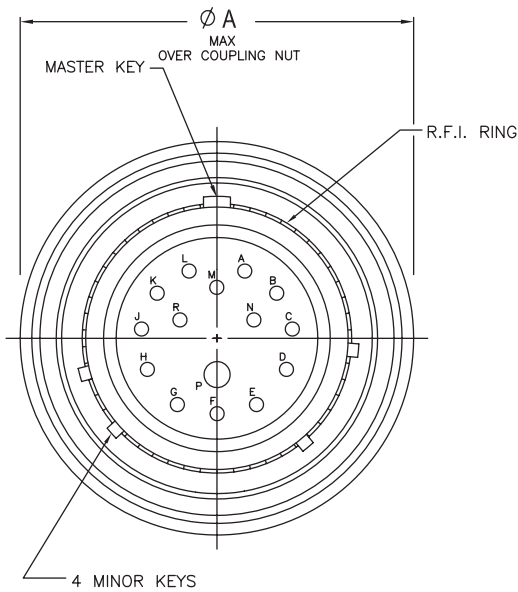

1515 ARRANGEMENT

MATING FACE OF PIN INSERT SHOWN  
 (REFERENCE ONLY)

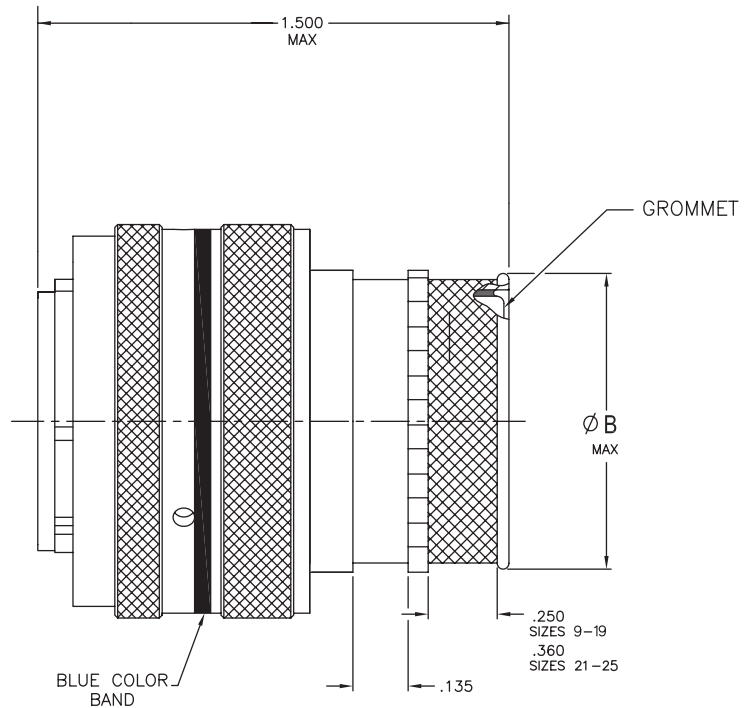

SHELL SIZE	ØA MAX	ØB MAX
9	.859	.453
11	.984	.571
13	1.156	.690
15	1.281	.847
17	1.406	.965
19	1.516	1.083
21	1.641	1.201
23	1.766	1.319
25	1.891	1.447

**AE 45-477 Jam Nut Receptacle with integrated Rear Banding Platform**

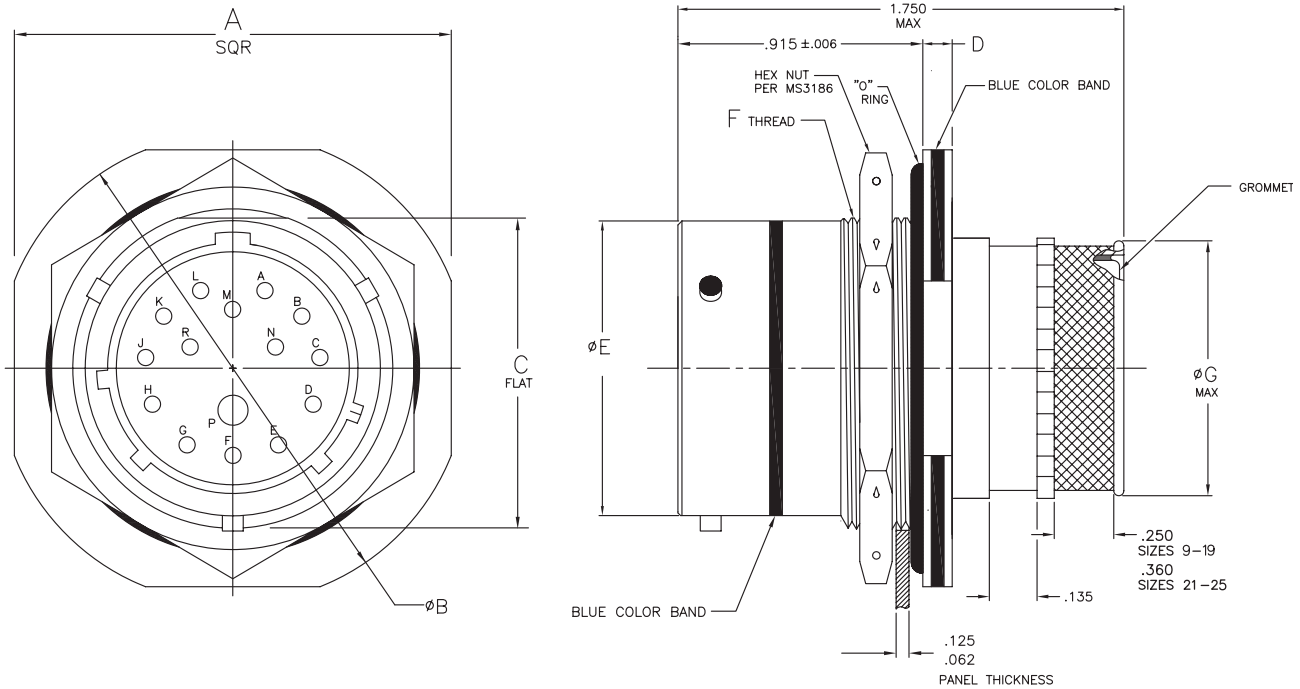

**INTEGRATED REAR**

SHELL SIZE	A	ØB	C FLAT	D	ØE	F Thread-2A	ØG MAX
	±.016	±.016	+0.001 -.010	+0.011 -.010	+0.001 -.005		
9	1.062	1.188	.655	.109	.572	.687-24	.453
11	1.250	1.375	.755	.109	.700	.812-20	.571
13	1.375	1.500	.942	.109	.850	1.000-20	.690
15	1.500	1.625	1.066	.109	.975	1.125-18	.847
17	1.625	1.750	1.191	.109	1.100	1.250-18	.965
19	1.812	1.938	1.316	.140	1.207	1.375-18	1.083
21	1.938	2.062	1.441	.140	1.332	1.500-18	1.201
23	2.062	2.188	1.566	.140	1.457	1.625-18	1.319
25	2.188	2.312	1.691	.140	1.582	1.750-18	1.447

**MIL-DTL-38999 Series I**  
**Integrated Rear Banding Platform**  
**(MS27656)**



**AE45-478 Rear Wall Mount Receptacle with integrated Rear Banding Platform**

INTEGRATED REAR

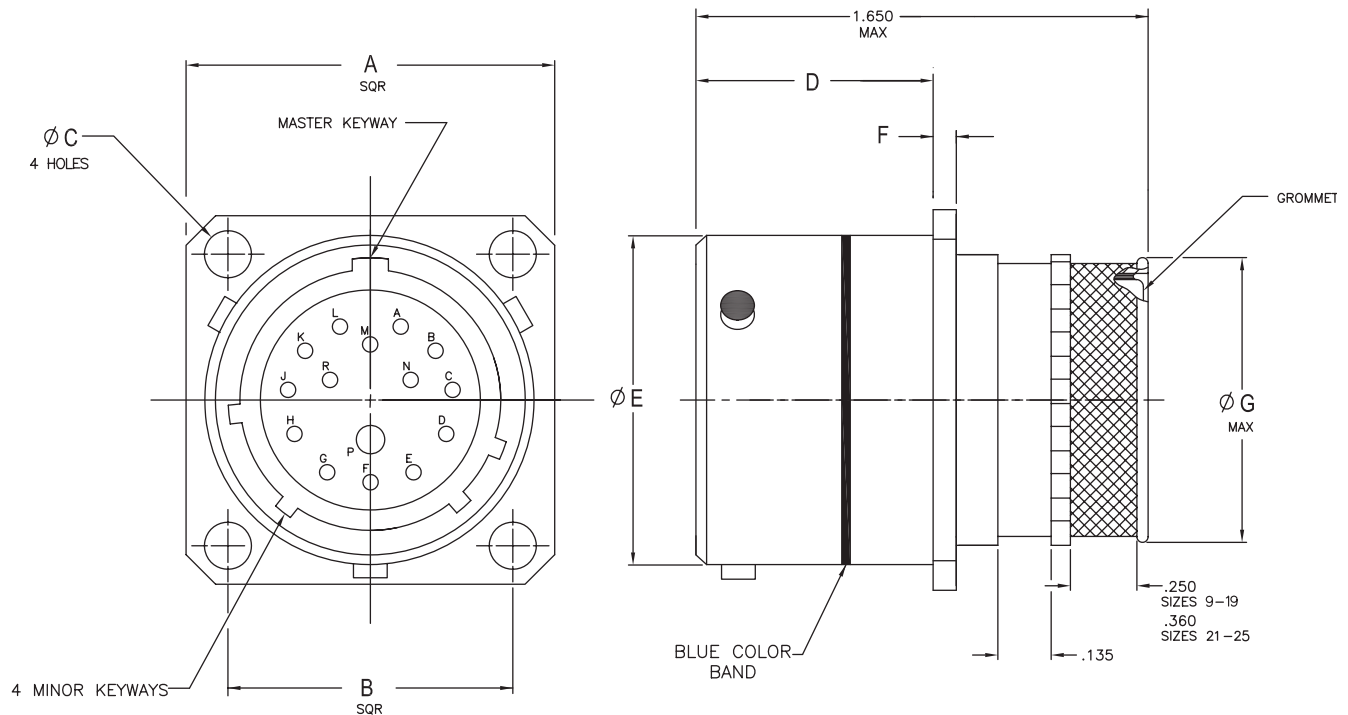

SHELL SIZE	A	B	ØC	D	ØE	F	ØG MAX
	±.020	BASIC	+0.010 -.005	+0.000 -.005	+0.001 -.005	+0.015 -.000	
9	.938	.719	.128	.820	.572	.085	.453
11	1.031	.812	.128	.820	.700	.085	.571
13	1.125	.906	.128	.820	.850	.085	.690
15	1.219	.969	.128	.820	.975	.085	.847
17	1.312	1.062	.128	.820	1.100	.085	.965
19	1.438	1.156	.128	.820	1.207	.085	1.083
21	1.562	1.250	.128	.790	1.332	.115	1.201
23	1.688	1.375	.147	.790	1.457	.115	1.319
25	1.812	1.500	.147	.790	1.582	.115	1.447



# MIL-DTL-38999 Series III Integrated Rear Banding Platform Part Number Development

## Part Number Configuration

Aero Prefix	AE65-	379-	W	B	98	S	N
<b>Shell Type</b>							
377 = Rear, Narrow Flange (Ref: D38999/20)							
378 = Rear, Jam Nut receptacle (Ref: D38999/24)							
379 = Plug Connector, RFI (Ref: D38999/26)							
<b>Material Finish</b>							
W = Aluminum, Olive Drab Cadmium over Nickel							
F = Aluminum, Electroless Nickel							
G = Stainless Steel, Passivated, Non-Firewall							
K = Stainless Steel, Passivated, Firewall							
BN = Aluminum, Black Nickel (RoHS)							
<b>Shell Size</b>							
A = 9, B = 11, C = 13, D = 15, E = 17, F = 19, G = 21, H = 23, J = 25							
<b>Insert Arrangement</b>							
Per MIL-STD-1560							
<b>Contact Style</b>							
P = Pin							
S = Socket							
A = Pin (Connectors used with other than Standard Contacts)							
B = Socket							
<b>Polarization (Keying)</b>							
N = Normal							
A, B, C, D and E							
<b>Note</b> = All minor keys are rotated to provide shell polarization, the master key remains fixed.							

INTEGRATED REAR

**MIL-DTL-38999 Series III**  
**Integrated Rear Banding Platform**  
**D38999/20**



**AE65-377 Wall Mount Receptacle with integrated Rear Banding Platform**

INTEGRATED REAR

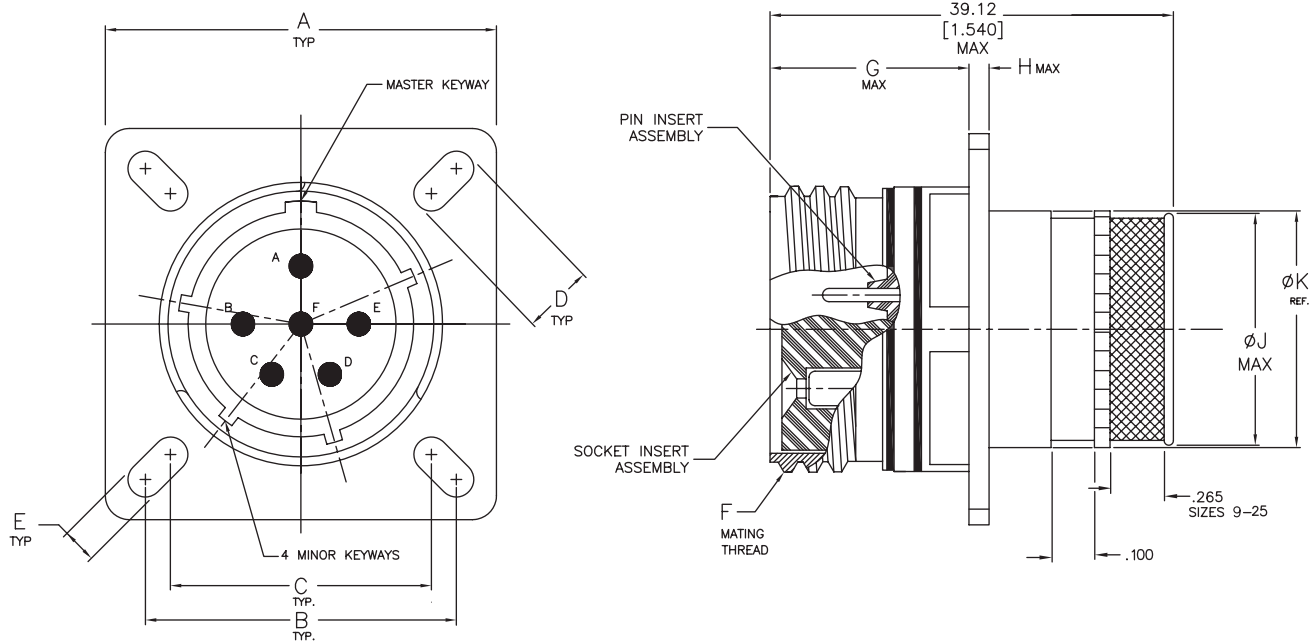

SHELL SIZE	SHELL CODE	A TYP		B TYP		C TYP		D TYP		E		F THREAD TRIPLE START	G MAX		H MAX		ØJ MAX		ØK REF.
		INCH ±.012	MM ±0.26	INCH ±.010	MM ±0.26	INCH ±.010	MM ±0.26	INCH ±.008	MM ±0.20	INCH ±.008	MM ±0.20		INCH	MM	INCH	MM	INCH	MM	
9	A	.937	23.80	.719	18.26	.594	15.09	.216	5.49	.128	3.25	.6250-1P-.3L	.820	20.83	.099	2.50	.453	11.50	.476
11	B	1.031	26.20	.812	20.62	.719	18.26	.194	4.93	.128	3.25	.7500-1P-.3L	.820	20.83	.099	2.50	.571	14.50	.594
13	C	1.126	28.60	.906	23.01	.812	20.62	.194	4.93	.128	3.25	.8750-1P-.3L	.820	20.83	.099	2.50	.690	17.53	.713
15	D	1.220	31.00	.969	24.61	.906	23.01	.194	4.93	.128	3.25	1.000-1P-.3L	.820	20.83	.099	2.50	.847	21.51	.870
17	E	1.311	33.30	1.062	26.97	.969	24.61	.194	4.93	.128	3.25	1.187-1P-.3L	.820	20.83	.099	2.50	.965	24.51	.988
19	F	1.437	36.50	1.156	29.36	1.062	26.97	.194	4.93	.128	3.25	1.250-1P-.3L	.820	20.83	.099	2.50	1.083	27.51	1.104
21	G	1.563	39.70	1.250	31.75	1.156	29.36	.194	4.93	.128	3.25	1.375-1P-.3L	.790	20.07	.126	3.20	1.201	30.51	1.226
23	H	1.689	42.90	1.375	34.93	1.250	31.75	.242	6.15	.154	3.91	1.500-1P-.3L	.790	20.07	.126	3.20	1.319	33.50	1.342
25	J	1.811	46.00	1.500	38.10	1.375	34.93	.242	6.15	.154	3.91	1.625-1P-.3L	.790	20.07	.126	3.20	1.447	36.75	1.460

**AE65-378 Jam Nut Receptacle with integrated Rear Banding Platform**

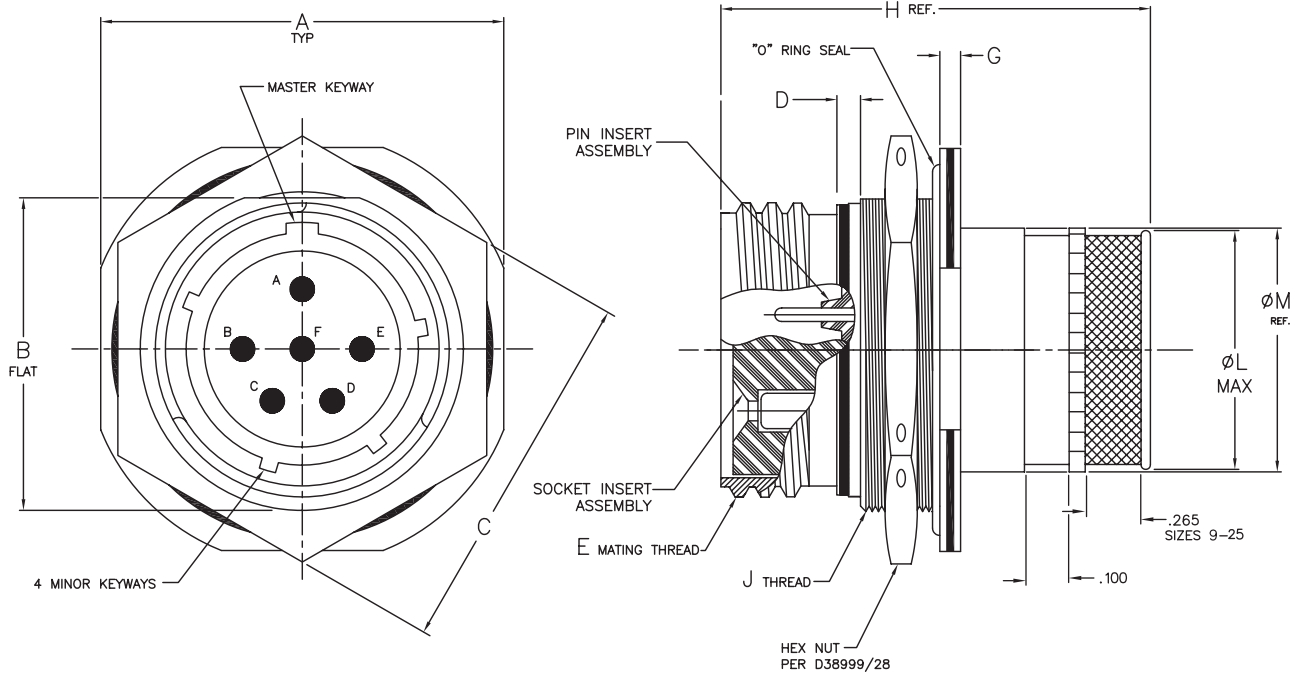

INTEGRATED REAR

SHELL SIZE	SHELL CODE	A	B MTG. FLAT	C HEX	D	E THREAD TRIPLE START	G	H REF.	J THREAD	ØL MAX	ØM REF.
		±.016	+0.004 -0.006								
9	A	1.063	.651	.945 .859	.555	.6250-1P-.3L	.087	1.580	M17x1.0-6g.100R	.453	.476
11	B	1.252	.751	1.063 .984	.555	.7500-1P-.3L	.087	1.580	M20x1.0-6g.100R	.571	.594
13	C	1.374	.983	1.260 1.172	.563	.8750-1P-.3L	.087	1.580	M25x1.0-6g.100R	.690	.713
15	D	1.500	1.062	1.417 1.296	.563	1.000-1P-.3L	.087	1.580	M28x1.0-6g.100R	.847	.870
17	E	1.626	1.187	1.457 1.422	.563	1.187-1P-.3L	.087	1.580	M32x1.0-6g.100R	.965	.988
19	F	1.811	1.312	1.614 1.546	.563	1.250-1P-.3L	.087	1.615	M35x1.0-6g.100R	1.083	1.104
21	G	1.937	1.437	1.811 1.672	.563	1.375-1P-.3L	.118	1.615	M38x1.0-6g.100R	1.201	1.226
23	H	2.063	1.562	1.969 1.796	.563	1.500-1P-.3L	.118	1.615	M41x1.0-6g.100R	1.319	1.342
25	J	2.189	1.687	2.017 1.939	.563	1.625-1P-.3L	.118	1.615	M44x1.0-6g.100R	1.447	1.460

**MIL-DTL-38999 Series III**  
**Integrated Rear Banding Platform**  
**D38999/26**



**AE65-379 Plug Connector, RFI, with integrated Rear Banding Platform**

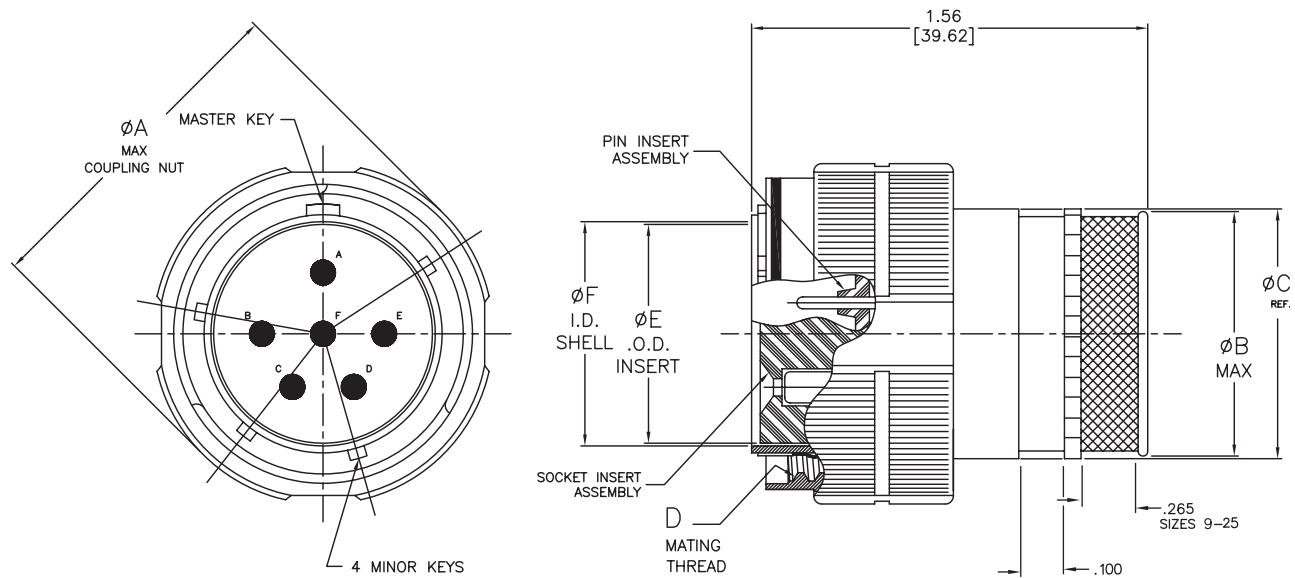

INTEGRATED REAR

SHELL SIZE	MS SHELL CODE	ØA MAX		ØB MAX		ØC REF.	D THREAD TRIPLE START	ØE		ØF	
		INCH	MM	INCH	MM			INCH +0.05 -0.09	MM +0.13 -0.25	INCH +0.05 -0.01	MM +0.13 -0.03
9	A	.858	21.8	.453	11.50	.476	.625-1P-3L	.285	7.24	.387	9.83
11	B	.984	25.0	.571	14.50	.594	.750-1P-3L	.412	10.49	.514	13.06
13	C	1.157	29.4	.690	17.53	.713	.875-1P-3L	.527	13.39	.628	15.95
15	D	1.279	32.5	.847	21.51	.870	1.000-1P-3L	.651	16.56	.753	19.13
17	E	1.405	35.7	.965	24.51	.988	1.187-1P-3L	.777	19.74	.878	22.30
19	F	1.515	38.5	1.083	27.51	1.104	1.250-1P-3L	.866	22.00	.972	24.69
21	G	1.641	41.7	1.201	30.51	1.226	1.375-1P-3L	.990	25.17	1.097	27.86
23	H	1.767	44.9	1.319	33.50	1.342	1.500-1P-3L	1.116	28.35	1.222	31.04
25	J	1.889	48.0	1.447	36.75	1.460	1.625-1P-3L	1.240	31.52	1.347	34.21

## Features and Application

MIL-DTL-26482 Series 2, bayonet coupling, rear-removable crimp contact connectors were designed as an upgrade to MIL-DTL-26482 Series 1. Series 2 connectors are intermountable and interchangeable with both solder and front-release crimp Series 1. They are also identical to the inactivated MIL-DTL- 83723 Series I connectors.

Series 2 connectors are widely used on commercial, military and aerospace systems requiring general-purpose, miniature cylindrical bayonet coupling connectors.

This family of connectors is offered in 4 receptacle-mounting styles. They include narrow flange wall mounting receptacles, wide flange wall mounting receptacles, cable connecting receptacles and jam nut mounting receptacles which incorporate “O” ring seals, designed for rear panel “D” hole mounting.

Plugs are available in two designs, with and without RFI grounding.

Thirty-three insert arrangements per MIL-STD-1669 are tooled and qualified to MIL-DTL-26482 Series 2, utilizing 3 to 61 M39029 contacts. Contacts come in sizes 20, 16 and 12, terminating wire sizes from 24 to 12 gauge.

These connectors are available in wide range of shell materials and finishes. Aluminum shells are offered in electroless nickel, olive drab cadmium and black anodic. Other finishes such as zinc cobalt are available upon request to commercial callouts only. In addition, we offer passivated stainless steel shells with standard environment-resisting inserts (commercial callouts only), and for highly corrosive environments, nickel-aluminum-bronze shells with standard environment-resisting inserts (commercial callouts only).

**Universal I/R Tool** – A single, expendable plastic tool is used for both insertion and removal of contacts.

**Insert Polarization** – Alternate insert clocking positions aid in mating of adjacent connectors having identical insert arrangement.

**Closed-Entry Socket Insert** – Hard dielectric socket face has lead-in chamfers for positive alignment of pins (even partially bent within pre-established limits) with sockets.

**Interfacial Pin Insert Seal** – Raised moisture barriers around each pin, which mate into lead-in chamfers of hard face socket insert, provide individual contact sealing. Interfacial seal is never touched by service tools.

**Elastomer Wire Sealing Grommet** – Sealing over a wide range of wire diameters is assured by a triple wire seal in each cavity at the rear of the connector.

**Superior Contact Stability** – Rear release crimp contact system features a stamped beryllium-copper retaining clip captivated by molded-in shoulders of each contact cavity in the insulator. A rear-inserted M81969 plastic tool expands the tines beyond the shoulder, releasing the contact.





## Performance Specifications

### Operating Temperature Range

Classes A, L and S\*: -55°C to +200°C (-67°F to +392°F)  
 Classes W, Z\* and BN\*: -55°C to +175°C (-67°F to +347°F)

### Material and Finish Data (Class)

A – aluminum shell, black anodized finish (RoHS)  
 L – aluminum shell, electroless nickel finish  
 W – aluminum shell, olive drab cadmium over nickel base  
 S\* – stainless steel shell, passivated (RoHS)  
 BN\* – aluminum shell, black nickel finish (Aero P/N only)  
 Z\* = Aluminum shell, Black Zinc Nickel finish (RoHS)  
 (Aero p/n only)

### Corrosion Resistance

Classes A, S\*, W and Z\* withstand 500-hour salt spray.  
 Class BN\* withstands 350-hours salt spray. Class L with-  
 stands 48-hour salt spray.

### Environmental Seal

Wired, mated connectors with specified accessories at-  
 tached, shall meet the altitude-immersion test specified in  
 MIL-DTL-26482 Series 2.

### Fluid Resistance

Connectors resist specified immersions in MIL-PRF-7808  
 (lubricating oil), MIL-PRF-23699 (lubricating oil),  
 MIL-PRF-5606 (hydraulic fluid), M2-V Chevron oil, Cool-  
 anol 25, ASTM D4814 (gasoline), SAE-AMS1424 Type I  
 (defrosting fluid), MIL-DTL-5624 (JP-5), and solvents  
 specified in Method 215 of MIL-STD-202.

\* Not on QPL, can be supplied to Aero-Electric P/N only.

### Durability

Mated connectors withstand a minimum of 250 mating  
 cycles for RFI plug (MS3475) and 500 cycles for standard  
 plug (MS3476).

### Shock and Vibration Requirements

Wired, mated connectors shall not be damaged, coupling  
 ring shall not loosen, and there shall be no interruption of  
 electrical continuity longer than one microsecond when  
 subjected to the following:

### Shock

Mated connectors withstand a pulse of approximate half  
 sine wave of 300 G magnitude with duration of three  
 milliseconds applied in each direction of the three major axes.

### Vibration

Mated connectors withstand the following vibration levels:

- Random vibration per MIL-STD-202, method 214, test  
 condition II, letter J.

### Shielding Effectiveness

RFI attenuation at the specified frequency meets the require-  
 ments of MIL-DTL-26482 Series 2.

- RFI shielding effectiveness of mated connectors with  
 RFI backshells is measured in a triaxial radio frequency  
 leakage fixture.

### Shell-to-Shell Conductivity

- With RFI spring fingers, the maximum potential drop  
 shall not exceed 5 millivolts.
- Without spring fingers, the maximum potential drop  
 shall not exceed 200 millivolts.

### Voltage Rating

Service Rating	Suggested Operating Voltage**		Test Voltage	Test Voltage	Test Voltage	Test Voltage
	(Sea Level)		Sea Level	50,000 Ft.	70,000 Ft.	110,000 Ft.
	AC (RMS)	DC	V RMS	V RMS	V RMS	V RMS
I	600	850	1,500	500	375	200
II	1,000	1,275	2,300	750	500	200

\*\* To be used by designer only as a guide.



**Military and Aero-Electric Part Number Development**

<b>Mil. Prefix</b>	<b>MS34</b>	<b>70</b>	<b>L</b>	<b>12 -</b>	<b>10</b>	<b>P</b>	<b>W</b>	
<b>Aero Prefix</b>	<b>AE7</b>	<b>70</b>	<b>L</b>	<b>12 -</b>	<b>10</b>	<b>P</b>	<b>W</b>	<b>-340</b>
<b>Shell type</b>								
70 = Narrow flange receptacle								
71 = Cable connecting receptacle								
72 = Wide flange receptacle								
74 = Jam nut receptacle								
75 = RFI grounding plug								
76 = Straight plug								
<b>Class (Material and Finish)</b>								
A = Aluminum shell, black anodized finish (not available in RFI plug) (RoHS)								
L = Aluminum shell, electroless nickel finish								
W = Aluminum shell, olive drab cadmium over electroless nickel base								
S* = Stainless steel shell, passivated (Aero part number only) (RoHS)								
BN* = Aluminum shell, Black Nickel finish, (RoHS), (Aero part number only) (N/A for AE775)								
Z* = Aluminum shell, Black Zinc Nickel finish (RoHS) (Aero p/n only) (N/A for AE775)								
<b>Shell Size</b>								
8, 10, 12, 14, 16, 18, 20, 22 or 24								
<b>Insert Arrangement</b>								
See pages 125 thru 126								
<b>Contact Style</b>								
P = Pin								
S = Socket								
A = Pin connector less pins (with intent to use non-std contact)								
B = Socket connector less sockets (with intent to use non-std contacts)								
<b>Polarization</b>								
N = Normal (not included in part number)								
W, X, Y or Z = Alternate insert polarizations (see pages 123 for position availability)								
<b>Modification (applies to Aero part numbers only)</b>								
01 = Less contacts (is not marked on the part)								
340 = Connector kitted with M85049/31-XXX E-nut								
341 = Connector kitted with M85049/52-1-XXX straight clamp								
342 = Connector kitted with M85049/51-1-XXX right angle clamp								

26482 S 2

\* Not on QPL, can be supplied to Aero part number only. Consult factory for availability.

**Note 1:** Each connector is furnished with contacts unless ordered less contacts (L/C) as follows: One spare contact for inserts requiring 2 to 26 of each contact and two spares for inserts with 27 or more of each size, and a minimum of one sealing plug up to 15% of the number of contacts. In addition, one plastic insertion/removal tool of each size is included.

**Note 2:** Proper part number marking has no “0” in front of single digit shell size ( 8) and no “0” after the dash between shell size and single digit layout. Example of each: MS3470W8-33P and MS3470W10-6P. In both “N” for normal was omitted.

**Note 3:** Insert layouts 8-2, 8-3 and 8-4 can only be ordered to Aero-Electric part number. Non standard contacts are required and to avoid confusion are sold “with contacts” only. See page 121 for the correct contact part numbers.

**MS3470**  
**Narrow Flange Receptacle**  
**AE770**



**Bayonet Coupling, Crimp Removable, Rear Release**

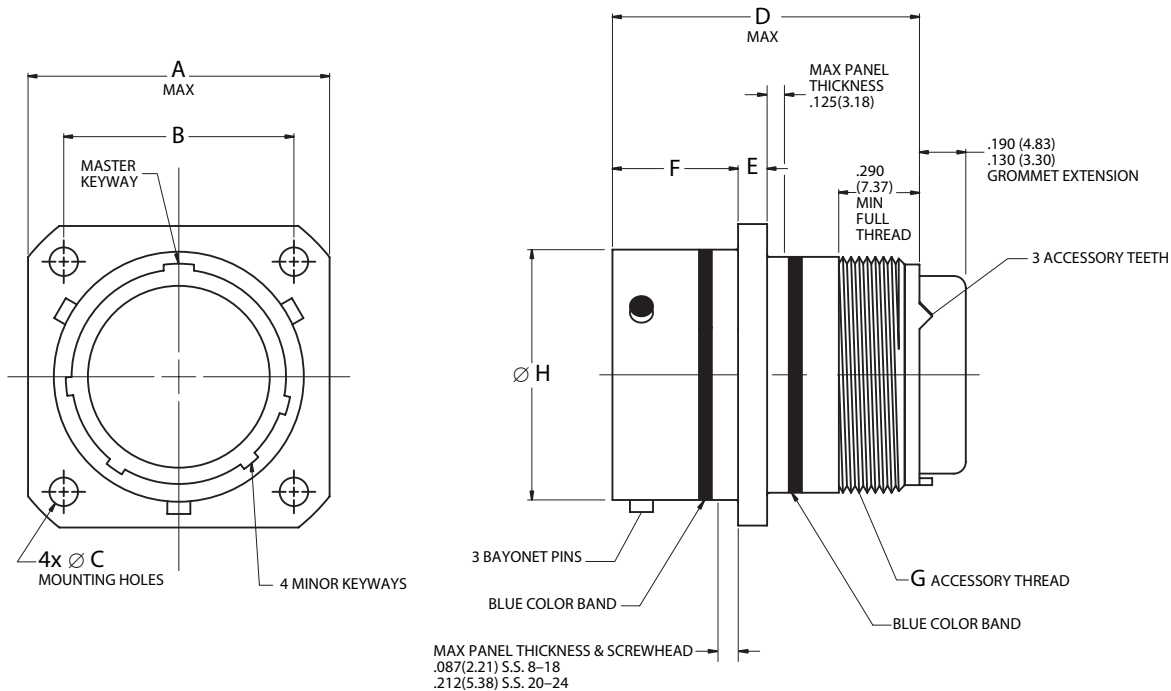

Page 110	Completed Part Number
Page 121	Contacts, Sealing Plugs and Tools
Pages 125, 126	Insert Arrangements
Page 109	Performance Specifications
Pages 123, 124	Insert Availability and Contact Information
Page 123	Polarization

**Note:** Maximum grommet O.D. is same as Ø C MAX on page 113.

Shell Size	A		B		Ø C		D		E		F		G	Ø H	
	Maximum		(TP)		±.005	±.13	Maximum		±.016	±.41	+0.016	+0.41	Accessory Thread Class 2A	±.003	±.08
	inch	mm	inch	mm	inch	mm	inch	mm	inch	mm	inch	mm		inch	mm
8	.828	21.03	.594	15.09	.120	3.05	1.215	30.86	.062	1.57	.446	11.33	1/2-20UNF	.471	11.96
10	.954	24.23	.719	18.26	.120	3.05	1.215	30.86	.062	1.57	.446	11.33	5/8-24UNEF	.588	14.94
12	1.047	26.59	.812	20.62	.120	3.05	1.215	30.86	.062	1.57	.446	11.33	3/4-20UNEF	.748	19.00
14	1.141	28.98	.906	23.01	.120	3.05	1.215	30.86	.062	1.57	.446	11.33	7/8-20UNEF	.873	22.17
16	1.234	31.34	.969	24.61	.120	3.05	1.215	30.86	.062	1.57	.446	11.33	1-20UNEF	.998	25.35
18	1.328	33.73	1.062	26.97	.120	3.05	1.215	30.86	.062	1.57	.446	11.33	1-1/16-18UNEF	1.123	28.52
20	1.453	36.91	1.156	29.36	.120	3.05	1.275	32.39	.094	2.39	.571	14.50	1-3/16-18UNEF	1.248	31.70
22	1.578	40.08	1.250	31.75	.120	3.05	1.275	32.39	.094	2.39	.571	14.50	1-5/16-18UNEF	1.373	34.87
24	1.703	43.26	1.375	34.93	.147	3.73	1.275	32.39	.094	2.39	.604	15.34	1-7/16-18UNEF	1.498	38.05

### Bayonet Coupling, Crimp Removable, Rear Release

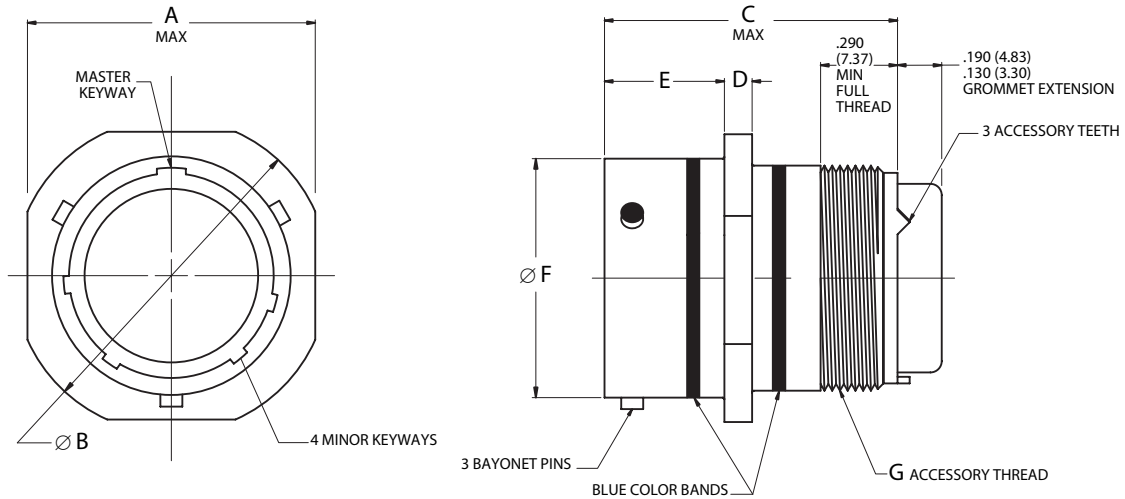

Page 110	Completed Part Number
Page 121	Contacts, Sealing Plugs and Tools
Pages 125, 126	Insert Arrangements
Page 109	Performance Specifications
Pages 123, 124	Insert Availability and Contact Information
Page 123	Polarization

**Note:** Maximum grommet O.D. is same as Ø C MAX on page 113.

26482 S 2

Shell Size	A		Ø B		C		D		E		Ø F		G
	Maximum		±.020	±.51	Maximum		±.016	±.41	+0.16	+0.41	±.003	±.08	
	inch	mm	inch	mm	inch	mm	inch	mm	inch	mm			
8	.828	21.03	.938	23.83	1.215	30.86	.062	1.57	.446	11.33	.471	11.96	1/2-20UNF
10	.954	24.23	1.062	26.97	1.215	30.86	.062	1.57	.446	11.33	.588	14.94	5/8-24UNEF
12	1.047	26.59	1.156	29.36	1.215	30.86	.062	1.57	.446	11.33	.748	19.00	3/4-20UNEF
14	1.141	28.98	1.250	31.75	1.215	30.86	.062	1.57	.446	11.33	.873	22.17	7/8-20UNEF
16	1.234	31.34	1.344	34.14	1.215	30.86	.062	1.57	.446	11.33	.998	25.35	1-20UNEF
18	1.328	33.73	1.438	36.53	1.215	30.86	.062	1.57	.446	11.33	1.123	28.52	1-1/16-18UNEF
20	1.453	36.91	1.562	39.67	1.275	32.39	.094	2.39	.571	14.50	1.248	31.70	1-3/16-18UNEF
22	1.578	40.08	1.688	42.88	1.275	32.39	.094	2.39	.571	14.50	1.373	34.87	1-5/16-18UNEF
24	1.703	43.26	1.812	46.02	1.275	32.39	.094	2.39	.604	15.34	1.498	38.05	1-7/16-18UNEF

**MS3472**  
**Wide Flange Receptacle**  
**AE772**



**Bayonet Coupling, Crimp Removable, Rear Release**

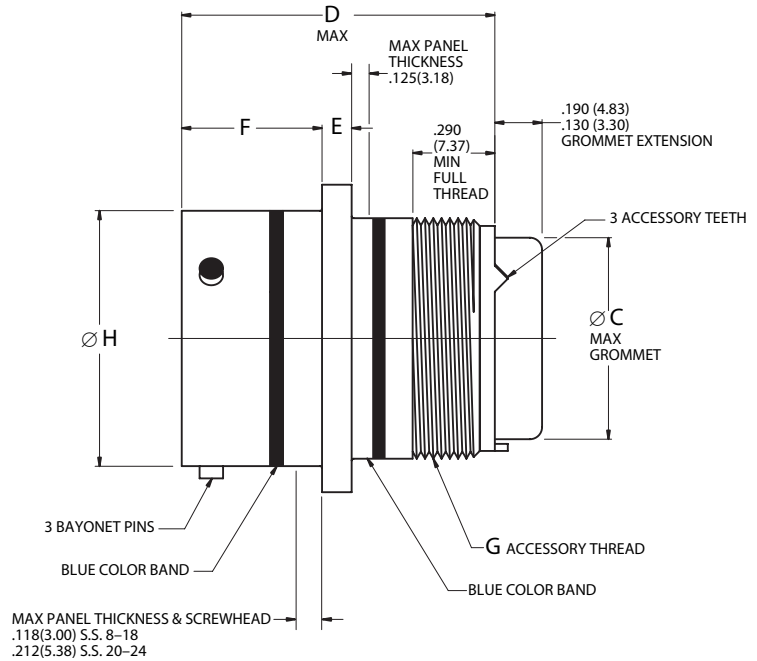
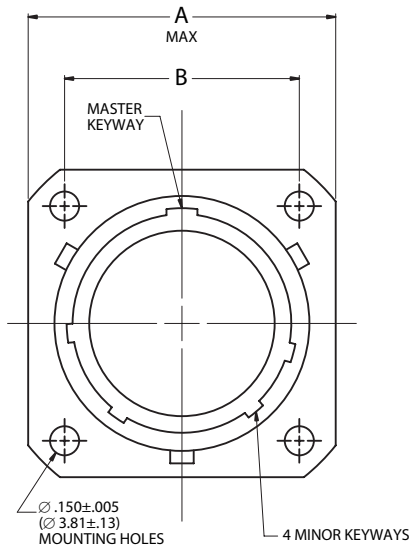

Page 110	Completed Part Number
Page 121	Contacts, Sealing Plugs and Tools
Pages 125, 126	Insert Arrangements
Page 109	Performance Specifications
Pages 123, 124	Insert Availability and Contact Information
Page 123	Polarization

26482 S 2

Shell Size	A		B		Ø C		D		E		F		G	Ø H	
	Maximum		(TP)		Maximum		Maximum		±.016	±.41	+016	+41	Accessory Thread Class 2A	±.003	±.08
	inch	mm	inch	mm	inch	mm	inch	mm	inch	mm	inch	mm		inch	mm
8	1.065	27.05	.734	18.64	.305	7.75	1.215	30.86	.062	1.57	.477	12.12	1/2-20UNF	.471	11.96
10	1.141	28.98	.812	20.62	.405	10.29	1.215	30.86	.062	1.57	.477	12.12	5/8-24UNEF	.588	14.94
12	1.266	32.16	.938	23.83	.531	13.49	1.215	30.86	.062	1.57	.477	12.12	3/4-20UNEF	.748	19.00
14	1.360	34.54	1.031	26.19	.665	16.89	1.215	30.86	.062	1.57	.477	12.12	7/8-20UNEF	.873	22.17
16	1.453	36.91	1.125	28.58	.790	20.07	1.215	30.86	.062	1.57	.477	12.12	1-20UNEF	.998	25.35
18	1.532	38.91	1.203	30.56	.869	22.07	1.215	30.86	.062	1.57	.477	12.12	1-1/16-18UNEF	1.123	28.52
20	1.688	42.88	1.297	32.94	.994	25.25	1.275	32.39	.094	2.39	.571	14.50	1-3/16-18UNEF	1.248	31.70
22	1.766	44.86	1.375	34.93	1.119	28.42	1.275	32.39	.094	2.39	.571	14.50	1-5/16-18UNEF	1.373	34.87
24	1.891	48.03	1.500	38.10	1.244	31.60	1.275	32.39	.094	2.39	.604	15.34	1-7/16-18UNEF	1.498	38.05

**Bayonet Coupling, Crimp Removable, Rear Release**

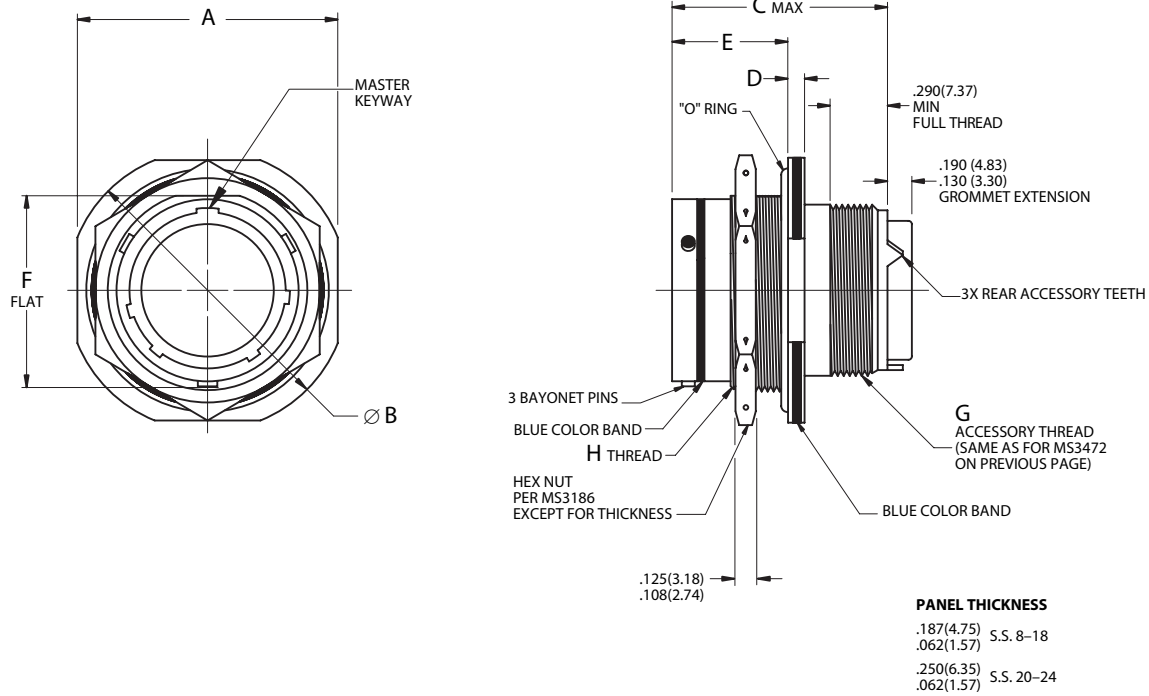

Page 110	Completed Part Number
Page 121	Contacts, Sealing Plugs and Tools
Pages 125, 126	Insert Arrangements
Page 109	Performance Specifications
Pages 123, 124	Insert Availability and Contact Information
Page 123	Polarization

**Note:** Maximum grommet O.D. is same as  $\varnothing$  E MAX on page 113.

26482 S 2

Shell Size	A		$\varnothing$ B		C		D		E		F		H
	+0.000	<b>+0.00</b>	+0.000	<b>+0.00</b>	Maximum						Flat		Jam Nut Thread
	-.031	<b>-.79</b>	-.031	<b>-.79</b>							$\pm$ .005	<b><math>\pm</math>.13</b>	
	inch	<b>mm</b>	inch	<b>mm</b>	inch	<b>mm</b>	inch	<b>mm</b>	inch	<b>mm</b>	inch	<b>mm</b>	UNEF-2A
8	.954	<b>24.23</b>	1.078	<b>27.38</b>	1.215	<b>30.86</b>	.113/.086	<b>2.87/2.18</b>	.707/.658	<b>17.96/16.71</b>	.525	<b>13.34</b>	9/16-24
10	1.078	<b>27.38</b>	1.203	<b>30.56</b>	1.215	<b>30.86</b>	.113/.086	<b>2.87/2.18</b>	.707/.658	<b>17.96/16.71</b>	.650	<b>16.51</b>	11/16-24
12	1.266	<b>32.16</b>	1.391	<b>35.33</b>	1.215	<b>30.86</b>	.113/.086	<b>2.87/2.18</b>	.707/.658	<b>17.96/16.71</b>	.813	<b>20.65</b>	7/8-20
14	1.391	<b>35.33</b>	1.516	<b>38.51</b>	1.215	<b>30.86</b>	.113/.086	<b>2.87/2.18</b>	.707/.658	<b>17.96/16.71</b>	.937	<b>23.80</b>	1-20
16	1.516	<b>38.51</b>	1.641	<b>41.68</b>	1.215	<b>30.86</b>	.113/.086	<b>2.87/2.18</b>	.707/.658	<b>17.96/16.71</b>	1.061	<b>26.95</b>	1-1/8-18
18	1.641	<b>41.68</b>	1.766	<b>44.86</b>	1.215	<b>30.86</b>	.113/.086	<b>2.87/2.18</b>	.707/.658	<b>17.96/16.71</b>	1.186	<b>30.12</b>	1-1/4-18
20	1.828	<b>46.43</b>	1.954	<b>49.63</b>	1.275	<b>32.39</b>	.148/.096	<b>3.76/2.44</b>	.772/.721	<b>19.61/18.31</b>	1.311	<b>33.30</b>	1-3/8-18
22	1.954	<b>49.63</b>	2.078	<b>52.78</b>	1.275	<b>32.39</b>	.148/.096	<b>3.76/2.44</b>	.772/.721	<b>19.61/18.31</b>	1.436	<b>36.47</b>	1-1/2-18
24	2.078	<b>52.78</b>	2.203	<b>55.96</b>	1.275	<b>32.39</b>	.148/.096	<b>3.76/2.44</b>	.772/.721	<b>19.61/18.31</b>	1.561	<b>39.65</b>	1-5/8-18

**MS3475**  
**RFI Grounding Plug**  
**AE775**



**Bayonet Coupling, Crimp Removable, Rear Release**

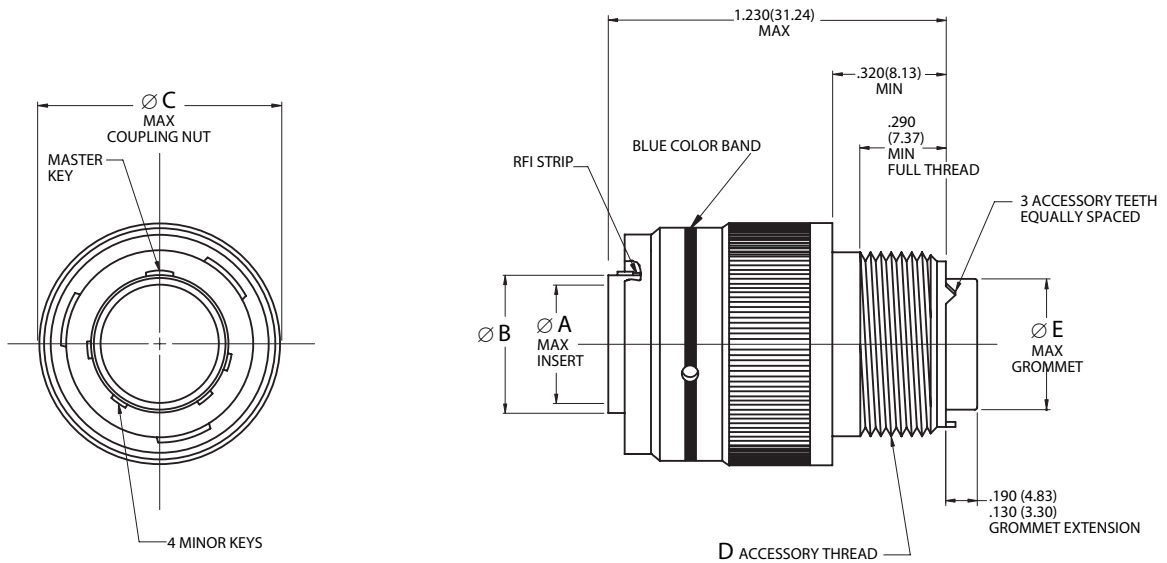

Page 110 Completed Part Number  
 Page 121 Contacts, Sealing Plugs and Tools  
 Pages 125, 126 Insert Arrangements  
 Page 109 Performance Specifications  
 Pages 123, 124 Insert Availability and Contact Information  
 Page 123 Polarization

26482 S 2

Shell Size	$\varnothing A$ Maximum		$\varnothing B$		$\varnothing C$ Maximum		D Accessory Thread Class 2A	$\varnothing E$ Maximum	
	inch	mm	$\pm.003$	$\pm.08$	inch	mm		inch	mm
			inch	mm					
8	.285	7.24	.355	9.02	.782	19.86	1/2-20UNF	.305	7.75
10	.402	10.21	.483	12.27	.926	23.52	5/8-24UNEF	.405	10.29
12	.516	13.11	.595	15.11	1.043	26.49	3/4-20UNEF	.531	13.49
14	.641	16.28	.720	18.29	1.183	30.05	7/8-20UNEF	.665	16.89
16	.766	19.46	.845	21.46	1.305	33.15	1-20UNEF	.790	20.07
18	.855	21.72	.945	24.00	1.391	35.33	1-1/16-18UNEF	.869	22.07
20	.980	24.89	1.070	27.18	1.531	38.89	1-3/16-18UNEF	.994	25.25
22	1.105	28.07	1.195	30.35	1.656	42.06	1-5/16-18UNEF	1.119	28.42
24	1.229	31.22	1.320	33.53	1.777	45.14	1-7/16-18UNEF	1.244	31.60

**Bayonet Coupling, Crimp Removable, Rear Release**

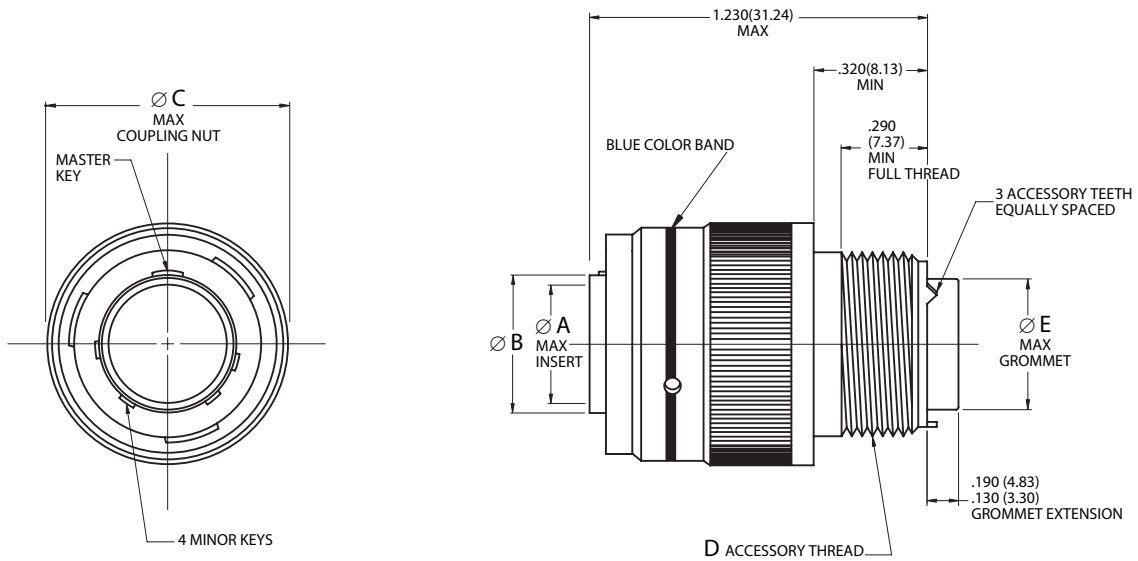

Page 110	Completed Part Number
Page 121	Contacts, Sealing Plugs and Tools
Pages 125, 126	Insert Arrangements
Page 109	Performance Specifications
Pages 123, 124	Insert Availability and Contact Information
Page 123	Polarization

26482 S 2

Shell Size	$\varnothing A$ Maximum		$\varnothing B$		$\varnothing C$ Maximum		D Accessory Thread Class 2A	$\varnothing E$ Maximum	
	inch	mm	$\pm .003$ inch	$\pm .08$ mm	inch	mm		inch	mm
8	.285	7.24	.355	9.02	.782	19.86	1/2-20UNF	.305	7.75
10	.402	10.21	.483	12.27	.926	23.52	5/8-24UNEF	.405	10.29
12	.516	13.11	.595	15.11	1.043	26.49	3/4-20UNEF	.531	13.49
14	.641	16.28	.720	18.29	1.183	30.05	7/8-20UNEF	.665	16.89
16	.766	19.46	.845	21.46	1.305	33.15	1-20UNEF	.790	20.07
18	.855	21.72	.945	24.00	1.391	35.33	1-1/16-18UNEF	.869	22.07
20	.980	24.89	1.070	27.18	1.531	38.89	1-3/16-18UNEF	.994	25.25
22	1.105	28.07	1.195	30.35	1.656	42.06	1-5/16-18UNEF	1.119	28.42
24	1.229	31.22	1.320	33.53	1.777	45.14	1-7/16-18UNEF	1.244	31.60



# AC3475 Arctic Coupling Nut, RFI Plug



## Bayonet Coupling, Crimp Removable, Rear Release

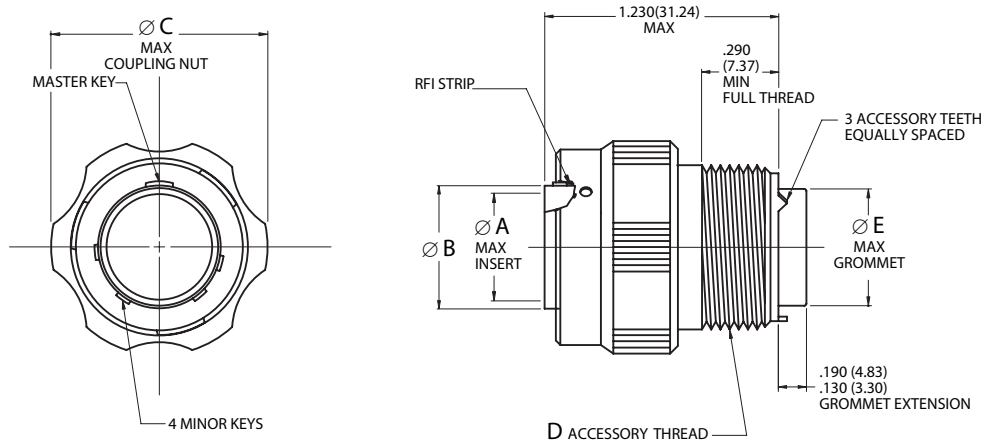

**AC3475** - **10-7-P-N**

**Aero Prefix** — AC3475

**Class (Material and Finish)** — -

- = Aluminum shell, cadmium olive drab for the plug shell – aluminum shell, hard anodized, black plating for the coupling nut  
L = Aluminum shell, electroless nickel

**Shell Size** — 10-7

8, 10, 12, 14, 16, 18, 20, 22 or 24

**Polarization** — N

N = Normal (N included in part number marking)  
A, B, C, D, E or F (Alternate key positions)  
and W, X, Y or Z (Alternate insert clocking positions)

**Contact Style** — P

P = Pin  
S = Socket

**Layout** — N

See pages 125 and 126

Page 110	Completed Part Number
Page 121	Contacts, Sealing Plugs and Tools
Pages 125, 126	Insert Arrangements
Page 109	Performance Specifications
Pages 123, 124	Insert Availability and Contact Information
Page 123	Polarization

**Note:** AC3475 Arctic Coupling Nut, RFI Plug is available to Aero-Electric part number only. Mating part is AC3474 which is same as AE774 on page 114. Additional mates are AC3470 (same as AE770 on page 111), AC3471 (same as AE771 on page 112) and AC3472 (same as AE772 on page 113).

Shell Size	Ø A		Ø B		Ø C		D Accessory Thread Class 2A	Ø E	
	Maximum		±.003	±.08	Maximum			Maximum	
	inch	mm	inch	mm	inch	mm		inch	mm
8	.285	7.24	.355	9.02	.900	22.86	1/2-20UNF	.305	7.75
10	.402	10.21	.483	12.27	1.010	25.65	5/8-24UNEF	.405	10.29
12	.516	13.11	.595	15.11	1.180	29.97	3/4-20UNEF	.531	13.49
14	.641	16.28	.720	18.29	1.310	33.27	7/8-20UNEF	.665	16.89
16	.766	19.46	.845	21.46	1.510	38.35	1-20UNEF	.790	20.07
18	.855	21.72	.945	24.00	1.620	41.15	1-1/16-18UNEF	.869	22.07
20	.980	24.89	1.070	27.18	1.740	44.20	1-3/16-18UNEF	.994	25.25
22	1.105	28.07	1.195	30.35	1.850	46.99	1-5/16-18UNEF	1.119	28.42
24	1.229	31.22	1.320	33.53	1.980	50.29	1-7/16-18UNEF	1.244	31.60

**Panel Cutouts**

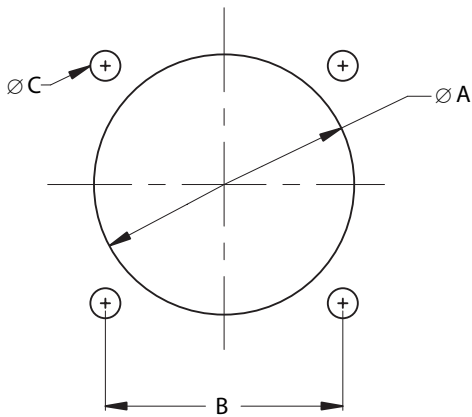

MS3470(AE770)

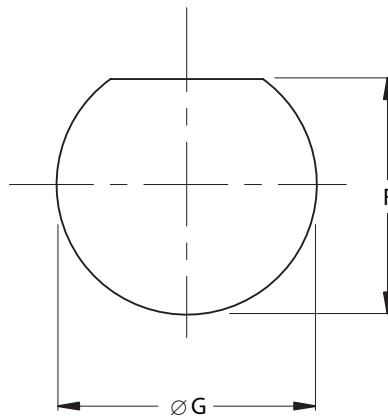

MS3474(AE774)

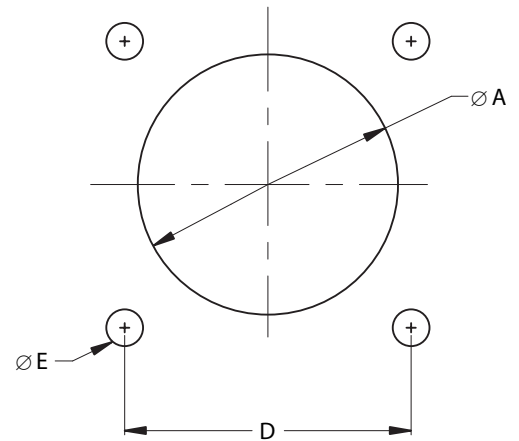

MS3472(AE772)

**Flange and Jam Nut Mounting Dimensions**

Shell Size	Ø A		B		Ø C		D		Ø E		F		Ø G	
	±.005	±.13	(TP)		±.010	±.25	(TP)		±.010	±.25	±.005	±.13	±.005	±.13
	inch	mm	inch	mm	inch	mm	inch	mm	inch	mm	inch	mm	inch	mm
8	.568	14.43	.594	15.09	.120	3.05	.734	18.64	.150	3.81	.536	13.61	.572	14.53
10	.685	17.40	.719	18.26	.120	3.05	.812	20.62	.150	3.81	.661	16.79	.697	17.70
12	.864	21.95	.812	20.62	.120	3.05	.938	23.83	.150	3.81	.824	20.93	.895	22.73
14	.989	25.12	.906	23.01	.120	3.05	1.031	26.19	.150	3.81	.948	24.08	1.010	25.65
16	1.113	28.27	.969	24.61	.120	3.05	1.125	28.58	.150	3.81	1.072	27.23	1.135	28.83
18	1.238	31.45	1.062	26.97	.120	3.05	1.203	30.56	.150	3.81	1.197	30.40	1.260	32.00
20	1.363	34.62	1.156	29.36	.120	3.05	1.297	32.94	.150	3.81	1.322	33.58	1.385	35.18
22	1.488	37.80	1.250	31.75	.120	3.05	1.375	34.93	.150	3.81	1.447	36.75	1.510	38.35
24	1.615	41.02	1.375	34.93	.147	3.73	1.500	38.10	.150	3.81	1.572	39.93	1.635	41.53

**Note:** For Ø C and Ø E, MS3470 and MS3472 call out for tolerance of ±.010 (±.25), however we recommend ±.005 (±.13).

**MS3180**  
**Protective Cover, Plug**  
**AE1580**



**Protective Cover, Plug**

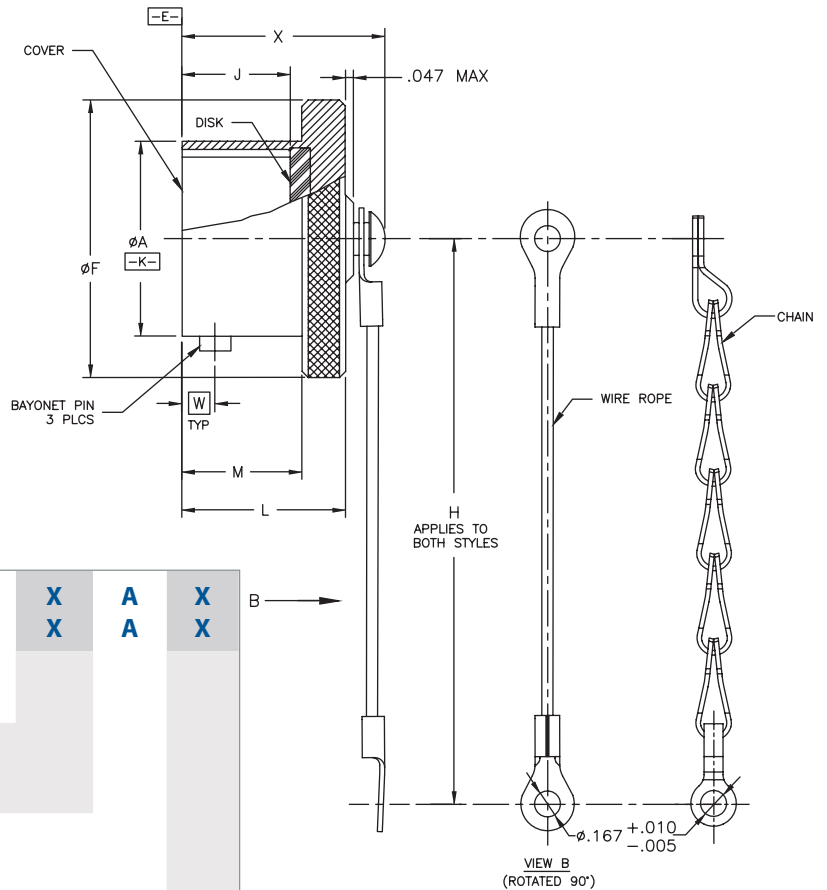

**Part Number Configuration**

<b>MIL. Prefix</b>	<b>MS3180-</b>	<b>XX</b>	<b>X</b>	<b>A</b>	<b>X</b>	B →
<b>Aero Prefix</b>	<b>AE1580-</b>	<b>XX</b>	<b>X</b>	<b>A</b>	<b>X</b>	
<b>Shell Size</b>						
8 THRU 24 (Note: single digit for shell size 8)						
<b>Style</b>						
C = Chain						
R = Wire Rope Assembly						
<b>Material Finish</b>						
A = Aluminum, Hard Black Anodized (RoHS)						
W = Aluminum, olive drab cadmium (Aero part # only)						
L = Aluminum, electroless nickel (Aero part # only)						
S = Stainless steel, passivated (Aero part # only) (RoHS)						
BN = Aluminum, Black Nickel finish (Aero part # only) (RoHS)						
Z = Aluminum, Black Zinc Nickel finish (Aero part # only) (RoHS)						
<b>Chain/Wire Rope Lengh</b>						
Blank - for standard length "H"						
L= 5.000 +500 -250						

SHELL SIZE	ØA +.001 -.005	ØB +.006 -.002	ØC +.000 -.016	ØD +.005 -.001	ØF MAX.	H +500 -250	J +.010 -.020	L Max.	M +.031 -.000	ØQ +.005 -.006	W	X MAX
8	.473	.078	.563	.362	.719	3.000	.328	.562	.368	.412	.100	.781
10	.590	.078	.680	.490	.844	3.000	.328	.562	.368	.540	.100	.781
12	.750	.078	.859	.607	1.000	3.500	.328	.562	.368	.689	.100	.781
14	.875	.078	.984	.732	1.125	3.500	.328	.562	.368	.814	.100	.781
16	1.000	.078	1.108	.857	1.250	3.500	.328	.562	.368	.939	.100	.781
18	1.125	.078	1.233	.962	1.375	3.500	.328	.562	.368	1.039	.100	.781
20	1.250	.078	1.358	1.087	1.500	4.000	.390	.625	.430	1.164	.100	.844
22	1.375	.078	1.483	1.212	1.625	4.000	.390	.625	.430	1.289	.100	.844
24	1.500	.078	1.610	1.337	1.750	4.000	.390	.625	.430	1.414	.109	.875

26482 S 2

**Protective Cover, Receptacle**

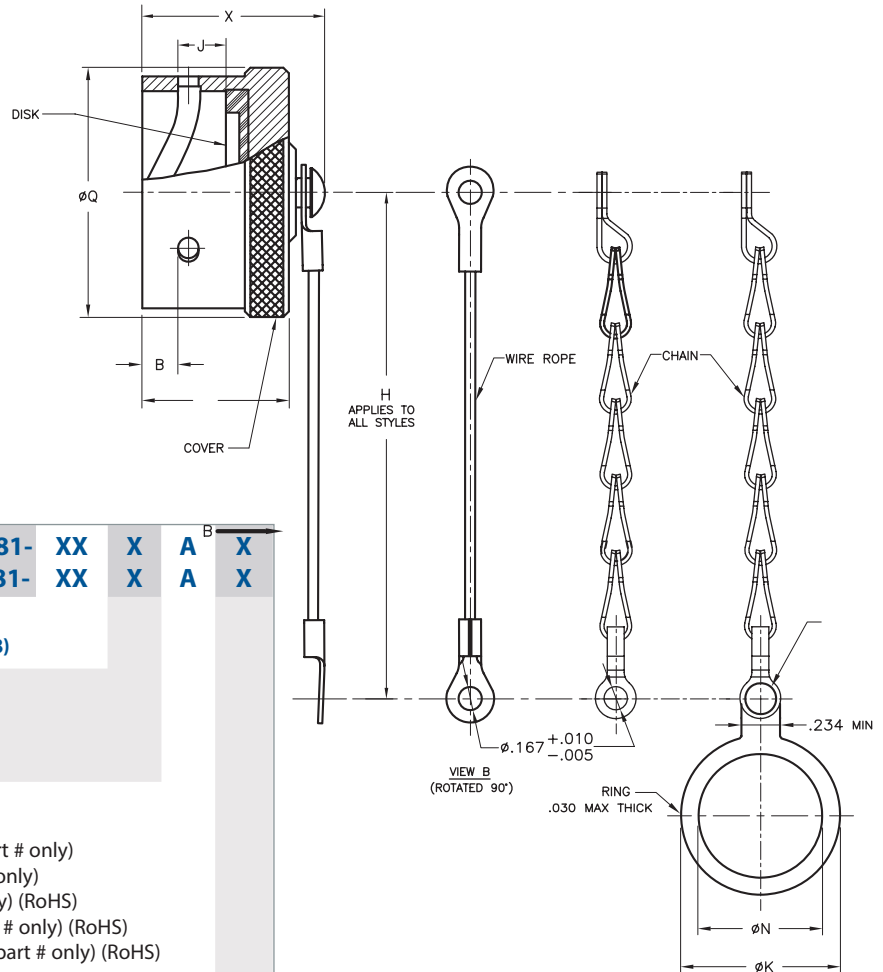

**Part Number Configuration**

<b>MIL. Prefix</b>	<b>MS3181-</b>	<b>XX</b>	<b>X</b>	<b>A</b>	<b>X</b>
<b>Aero Prefix</b>	<b>AE1581-</b>	<b>XX</b>	<b>X</b>	<b>A</b>	<b>X</b>
<b>Shell Size</b>	<b>8 THRU 24 (Note: single digit for shell size 8)</b>				
<b>Style</b>	<ul style="list-style-type: none"> <li>C = Chain</li> <li>R = Wire Rope Assembly</li> <li>N = Chain/Ring Assembly</li> </ul>				
<b>Material Finish</b>	<ul style="list-style-type: none"> <li>A = Aluminum, Hard Black Anodized (RoHS)</li> <li>W = Aluminum, olive drab cadmium (Aero part # only)</li> <li>L = Aluminum, electroless nickel (Aero part # only)</li> <li>S = Stainless steel, passivated (Aero part # only) (RoHS)</li> <li>BN = Aluminum, Black Nickel finish (Aero part # only) (RoHS)</li> <li>Z = Aluminum, Black Zinc Nickel finish (Aero part # only) (RoHS)</li> </ul>				
<b>Chain/Wire Rope Lengh</b>	Blank - for standard length "H"				
	L= 5.000 +500 -.250				

SHELL SIZE	ØA +.001 -.005	B +.006 -.002	ØG +.005 -.006	H +.500 -.250	J +.010 -.020	L Max.	ØN MIN.	ØQ +.005 -.006	ØK MAX	X MAX
8	.481	.149	.576	3.000	.115	.562	.578	.734	.812	.844
10	.602	.149	.697	3.000	.115	.562	.703	.859	1.000	.844
12	.761	.149	.871	3.500	.115	.562	.891	1.000	1.188	.844
14	.885	.149	.995	3.500	.115	.562	1.016	1.125	1.438	.844
16	1.010	.149	1.120	3.500	.115	.562	1.141	1.250	1.562	.844
18	1.136	.149	1.245	3.500	.115	.562	1.266	1.375	1.688	.844
20	1.260	.149	1.370	4.000	.115	.562	1.391	1.500	1.812	.844
22	1.385	.149	1.495	4.000	.115	.562	1.516	1.625	1.938	.844
24	1.510	.087	1.624	4.000	.147	.602	1.641	1.750	2.062	.875

26482 S 2

# MIL-DTL-26482

## Contacts, Tools and Seal Plugs

### Series 2



#### Contacts, Plastic Insertion/Removal Tools and Seal Plugs

Contact Size	Application	Pin Contacts	Socket Contacts	Seal Plugs	Insertion/Removal Tools
	Type	Military No.	Military No.	Military No.	Military No.
20	Power/Signal	M39029/4-110	M39029/5-115	MS27488-20-1	M81969/14-11
16	Power/Signal	M39029/4-111	M39029/5-116	MS27488-16-1	M81969/14-03
12	Power/Signal	M39029/4-113	M39029/5-118	MS27488-12-1	M81969/14-04
20*	Power/Signal	5291-022-204H	5091-022-204H	MS27488-20-1	M81969/39-01

\* Size 20 contacts for 8-2, 8-3 and 8-4 layouts are only available to Aero-Electric part numbers. Connectors incorporating these three layouts are only sold to Aero-Electric callouts (AE770, AE771, AE772, AE774, AE775, AE776, AC3470, AC3471, AC3472, AC3474 and AC3475). Standard size 20 contacts M39029/4-110 and M39029/5-115 will not work in these 3 layouts.

#### Crimping and Metal Insertion/Extraction Tools

Contact Size	Crimp Tool	Positioner	Positioner	Insertion Tool	Extraction Tool
	Military No.	For Pin Contacts Military No.	For Socket Contacts Military No.	Metal Military No.	Metal Military No.
20	M22520/1-01	M22520/1-02	M22520/1-02	M81969/8-205	M81969/8-206
	M22520/2-01	M22520/2-02	M22520/2-02		
16	M22520/1-01	M22520/1-02	M22520/1-02	M81969/8-207	M81969/8-208
12	M22520/1-01	M22520/1-02	M22520/1-02	M81969/8-209	M81969/8-210
20*	M22520/2-01	M22520/2-08	M22520/2-08	M81969/8-205	M81969/8-206

#### Contact and Wire Data

Contact Size	Test Current	Voltage	Crimp Well Data			Wire Range		Finished Wire Ø Range			
	DC Test	Max. Drop	Well Dia.	Minimum Well Dept				Minimum		Maximum	
	Amps	Millivolts	inch	inch	mm	AWG	mm <sup>2</sup>	inch	mm	inch	mm
20	7.5	55	.049 ±.001	.155	<b>3.94</b>	24-20	<b>.20-.52</b>	.040	<b>1.02</b>	.083	<b>2.11</b>
16	13.0	49	.067 ±.001	.250	<b>6.35</b>	20-16	<b>.52-1.31</b>	.053	<b>1.35</b>	.103	<b>2.62</b>
12	23.0	42	.100 ±.002	.250	<b>6.35</b>	14-12	<b>2.08-3.31</b>	.097	<b>2.46</b>	.158	<b>4.01</b>

**Note:** Test Current and Maximum Voltage Drop when tested with silver-plated wire at 25°C.

# Contact Installation Instructions

## Crimping Contacts

1. Select the appropriate crimp tool and ensure that the proper crimp head positioner is used.
2. Cycle the tool to be sure the indentors are open.
3. Determine the correct selector setting for the wire size from the data plate on the positioner (turret head assembly) and set the selector knob on the crimp tool to match.
4. Place the contact, mating end first, into the tool.
5. Insert the stripped wire into the hollow end of the contact. Be sure the wire is inserted as far as it will go.
6. Close the tool completely to crimp. Unless the tool is closed completely, the tool will not release the contact.
7. Remove the crimped contact from the tool. Check the inspection hole to verify that the wire is fully inserted.

## Insertion of Contacts

1. Before inserting the contacts, unscrew the accessories (clamps, backshells or adapters) from rear of plug or receptacle. Slide the hardware over the wire bundle in the proper order for reassembly after all the contacts are inserted.
2. To assist insertion of contacts, lubricate insulator (grommet) cavities with isopropyl alcohol. Alcohol will evaporate and will not leave a conductive film. **Caution: Never use any lubricant other than isopropyl alcohol.**

3. Place the correct insertion tool on the contact so that the wire runs along the groove in the tool. (Tool tip will butt against the shoulder.) Hold the plug or receptacle body firmly.
4. Beginning with a center cavity, insert the contact into the insulator with a slow, even pressure until the contact snaps into position. Make sure the contact and tool are held perpendicular to the face of the insert during the contact installation or the grommet could be damaged.
  - 4.1 If contacts are not inserted all the way prior to removing insertion tool, do not try to reinsert the insertion tool. Instead, remove the contact and try again; otherwise reinserting the insertion tool may damage the inside of the contact cavity.
5. Remove tool and check the face of the connector for proper contact installation. Proper installation may also be checked by pulling back lightly on the wire to make sure the contact is properly seated.

## Completion

After all the cavities have been filled, slide the hardware back into position on the connector and tighten.

## Extraction of Contacts (Rework)

1. Slide the hardware back over the wire bundle.
2. Select the appropriate tool. Place the wire into the extraction tool of the pin or socket.
3. Slowly slide the extraction tool down wire into the contact cavities until the tool tip bottoms against the contact shoulder, expanding the clip retaining tines. Hold the wire firmly in the tool and pull the wired contact and tool straight out of the rear of the insulator.

Size	Pin Contact	Socket Contact	Basic Crimp Tool	Pin Positioner	Socket Positioner	Insertion/Removal Tool
20	M39029/4-110	M39029/5-115	M22520/1-01	M22520/1-02 Red	M22520/1-02 Red	M81969/14-11
			M22520/2-01	M22520/2-02	M22520/2-02	
16	M39029/4-111	M39029/5-116	M22520/1-01	M22520/1-02 Blue	M22520/1-02 Blue	M81969/14-03
12	M39029/4-113	M39029/5-118	M22520/1-01	M22520/1-02 Yellow	M22520/1-02 Yellow	M81969/14-04
20*	5291-022-204H	5091-022-204H	M22520/2-01	M22520/2-08	M22520/2-08	M81969/39-01

\* Aero-Electric proprietary size 20 contacts used in 8-2, 8-3 and 8-4 layouts only.

# MIL-DTL-26482 Series 2

## Polarization, Insert Availability & Contact Information

### per MIL-STD-1669



#### Polarization (Insert Clocking)

1. In the normal insert clocking position (position N), the insert centerline coincides with the centerline of the master keyway (key) of the shell:  $L = 0^\circ$ .
2. In the alternate clocking positions (W, X, Y and Z), the pin insert (viewing from mating side) is rotated clockwise relative to the centerline of the master keyway (key) of the shell.
3. The socket insert is rotated counter-clockwise.
4. Plugs have keys; receptacles have keyways.

**Note:** Be careful with alternate positions. See table below for position availability on layouts of interest.

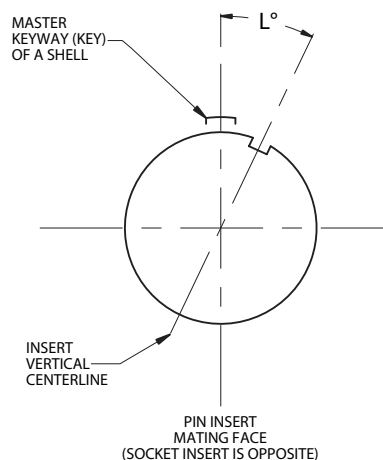

### Insert Availability, Contact Information and Clocking Positions

Insert Arrangement	Aero-Electric		Total	Contact Quantity			Service	Insert Positions				
	Status		No. of	By Size			Rating	In Degrees				
	QPL'd	Tooled	Contacts	20	16	12		N	W	X	Y	Z
8-2*	No	Yes	2	2			I	0	58	122	—	—
8-3*	No	Yes	3	3			I	0	60	210	—	—
8-4*	No	Yes	4	4			I	0	45	—	—	—
8-33	Yes	Yes	3	3			I	0	90	—	—	—
8-98	Yes	Yes	3	3			I	0	—	—	—	—
10-6	Yes	Yes	6	6			I	0	90	—	—	—
10-7**	N/A	Yes	7	7			I	0	90	—	—	—
12-3	Yes	Yes	3		3		II	0	—	—	180	—
12-8	Yes	Yes	8	8			I	0	90	112	203	292
12-10	Yes	Yes	10	10			I	0	60	155	270	295
14-2**	N/A	Yes	2			2	I	0	—	—	—	—
14-4	Yes	Yes	4			4	I	0	45	—	—	—
14-5	Yes	Yes	5		5		II	0	40	92	184	273
14-9	Yes	Yes	9	5		4	I	0	15	90	180	240
14-12	Yes	Yes	12	8	4		I	0	43	90	—	—
14-15	Yes	Yes	15	14	1		I	0	17	110	155	234
14-18	Yes	Yes	18	18			I	0	15	90	180	270
14-19	Yes	Yes	19	19			I	0	30	165	315	—

\* Not qualified to MIL-DTL-26482 Series 2. These layouts were designed to mate with solder Series 1 connectors using proprietary Aero-Electric contacts (not QPL'd to M39029) and to avoid confusion are sold only "with contacts".

\*\* Non MIL-STD-1669 layouts, available to Aero-Electric part numbers only and utilize standard M39029 contacts. These layouts were originally designed for use in AC3475 Arctic Coupling RFI plugs and AC3474 jam nut receptacles.



**MIL-DTL-26482 Series 2**  
**Polarization, Insert Availability & Contact Information**  
**per MIL-STD-1669**

**Insert Availability, Contact Information and Clocking Positions**

Insert Arrangement	Aero-Electric		Total	Contact Quantity			Service	Insert Positions				
	Status		No. of	By Size				In Degrees				
	QPL'd	Tooled	Contacts	20	16	12	Rating	N	W	X	Y	Z
16-8	Yes	Yes	8		8		II	0	54	152	180	331
16-14	Yes	Yes	14	8		6	I	0	25	78	180	240
16-23	Yes	Yes	23	22	1		I	0	158	270	—	—
16-26	Yes	Yes	26	26			I	0	60	—	275	338
18-8	Yes	Yes	8			8	I	0	180	—	—	—
18-11	Yes	Yes	11		11		II	0	62	119	241	340
18-30	Yes	Yes	30	29	1		I	0	180	193	285	350
18-32	Yes	Yes	32	32			I	0	85	138	222	265
20-16	Yes	Yes	16		16		II	0	238	318	333	347
20-24	Yes	Yes	24	24			I	0	70	145	215	290
20-39	Yes	Yes	39	37	2		I	0	63	144	252	333
20-41	Yes	Yes	41	41			I	0	45	126	225	—
22-12	Yes	Yes	12			12	I	0	—	—	—	—
22-21	Yes	Yes	21		21		II	0	16	135	175	349
22-41	Yes	Yes	41	27	14		I	0	39	135	264	—
22-55	Yes	Yes	55	55			I	0	30	142	226	314
22-95	Yes	Yes	32	26		6	I	0	26	180	266	—
24-19	Yes	No	19			19	II	0	30	165	315	—
24-31	Yes	Yes	31		31		I	0	90	225	255	—
24-61	Yes	Yes	61	61			I	0	90	180	270	324

26482 S 2



**MIL-STD-1669**  
**Insert Arrangements (Pin Front View)**  
**for MIL-DTL-26482 Series 2 Connectors**



**Insert Arrangement Views**

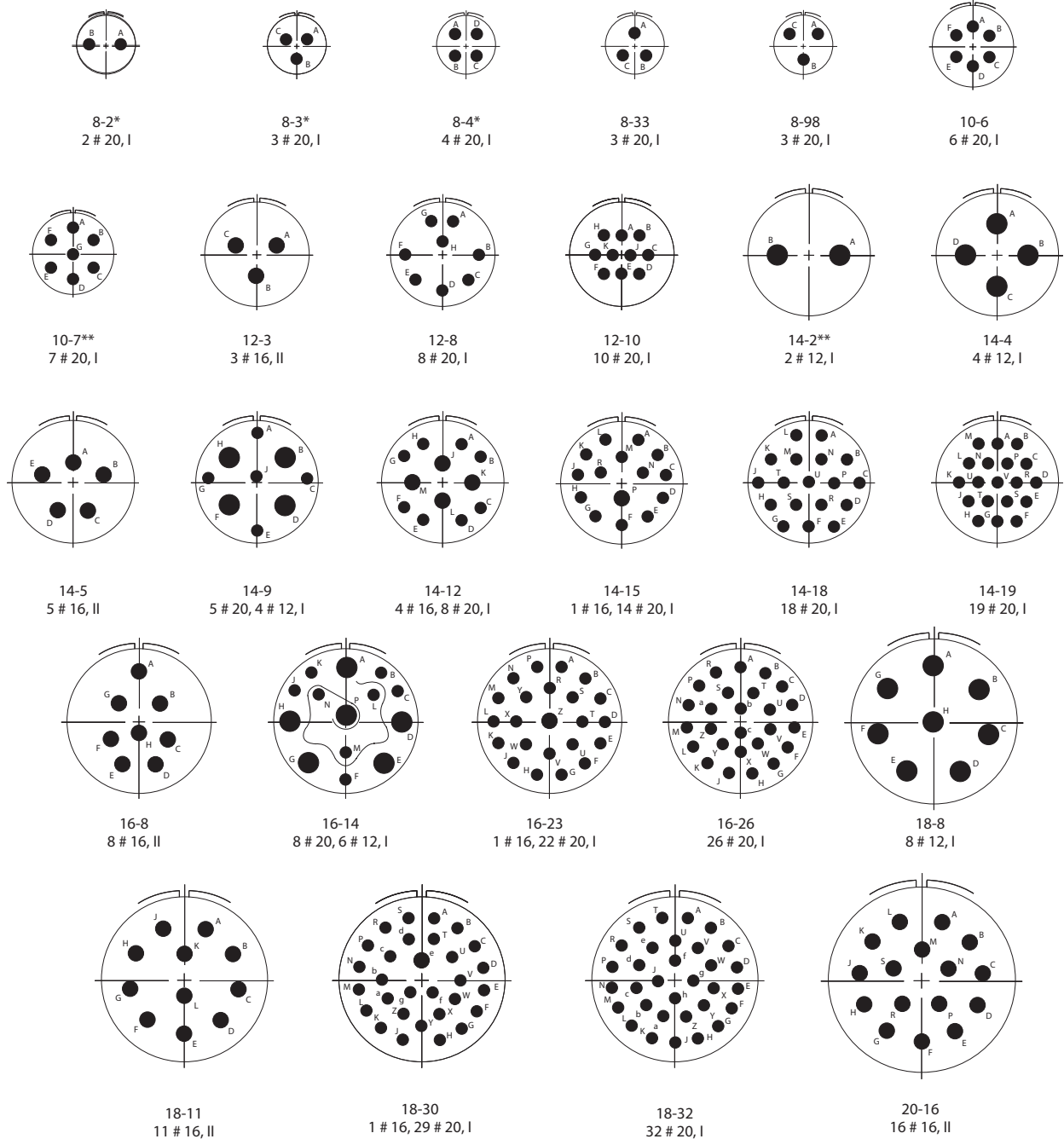

26482 S 2

\* Not on QPL, available to Aero-Electric part number only.

\*\* Non MIL-STD-1669 layout, available in AC3470 through AC3475 shell styles only.

Insert Arrangement Views

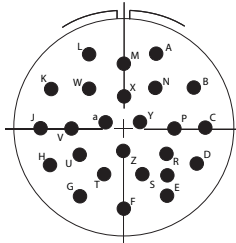

20-24  
24 # 20, I

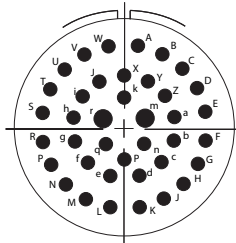

20-39  
2 # 16, 37 # 20, I

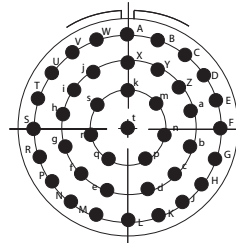

20-41  
41 # 20, I

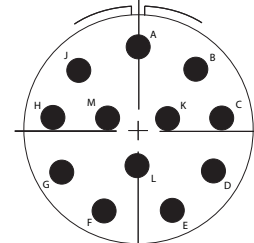

22-12  
12 # 12, I

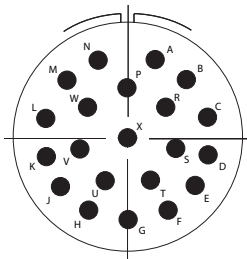

22-21  
21 # 16, II

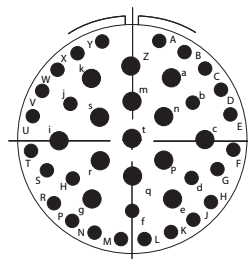

22-41  
14 # 16, 27 # 20, I

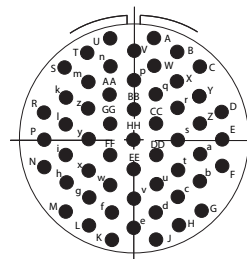

22-55  
55 # 20, I

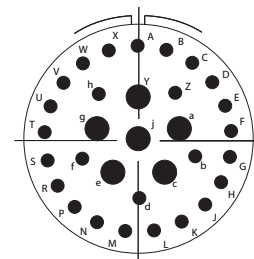

22-95  
6 # 12, 26 # 20, I

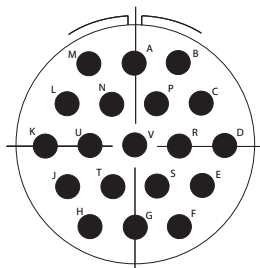

24-19  
19 # 12, II

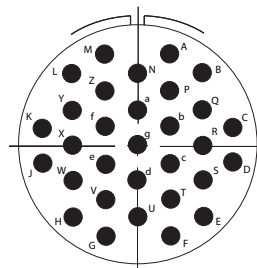

24-31  
31 # 16, I

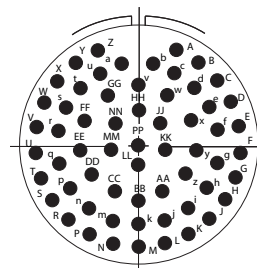

24-61  
61 # 20, I

26482 S 2

# MIL-DTL-83723 Series III Features and Application Bayonet and Threaded Coupling



## Features and Application

MIL-DTL-83723 Series III family offers connectors with bayonet and threaded coupling including lanyard-release quick-disconnects. These connectors combine the best features of MIL-DTL-26500 and NAS 1599 miniature connector specifications. They are intermateable with both bayonet and threaded 26500 connectors (exception: shell size 8, threaded coupling only) and have the added advantage provided by the rear-release contact retention system.

AE833 connectors are widely used on commercial, military and aerospace systems requiring general-purpose, miniature cylindrical bayonet or threaded coupling connectors. In addition, Series III threaded connectors with self-locking plugs are well suited for engine applications.

This family of connectors (bayonet as well as threaded) is offered in wall mount receptacles as well as jam nut mounted receptacles which incorporate “O” ring seals, designed for rear panel “D” hole mounting.

Series III bayonet-coupling plugs are available in two designs - with and without RFI grounding. Threaded coupling plugs are offered with and without RFI grounding, self-locking and RFI/self-locking. In addition we offer quick-disconnect (lanyard release) plugs, which mate with threaded receptacles via an adapter.

Thirty-one insert arrangements per MIL-STD-1554 are tooled and qualified to MIL-DTL-83723 Series III, utilizing 2 to 61 M39029 contacts. Contacts come in sizes 20, 16 and 12, terminating wire sizes from 24 to 12 gauge.

These connectors are available in wide range of shell materials and finishes. Aluminum shells are offered in electroless nickel, olive drab cadmium and black anodic. Other finishes such as zinc cobalt are available upon request to commercial callouts only. In addition, we offer passivated stainless steel shells with both standard and firewall-rated inserts, and for highly corrosive environments, nickel-aluminum-bronze shells with standard environment-resisting inserts (commercial callouts only).

**Universal I/R Tool** – A single, expendable plastic tool is used for both insertion and removal of contacts.

**Shell Polarization** – Alternate key/keyway positions prevent cross mating of adjacent connectors having same insert arrangement.

**Closed-Entry Socket Insert** – Hard dielectric socket face has lead-in chamfers for positive alignment of pins (even partially bent within pre-established limits) with sockets.

**Interfacial Pin Insert Seal** – Raised moisture barriers around each pin, which mate into lead-in chamfers of hard face socket insert, provide individual contact sealing. Interfacial seal is never touched by service tools.

**Elastomer Wire Sealing Grommet** – Sealing over a wide range of wire diameters is assured by a triple wire seal in each cavity at the rear of the connector.

**Superior Contact Stability** – Rear release crimp contact system features a stamped beryllium-copper retaining clip captivated by molded-in shoulders of each contact cavity in the insulator. A rear-inserted M81969 plastic tool expands the tines beyond the shoulder, releasing the contact.





# MIL-DTL-83723 Series III Performance Specifications Bayonet and Threaded Coupling

## Performance Specifications

### Operating Temperature Range

Classes A and R: -65°C to +200°C (-85°F to +392°F)  
 Class W: -65°C to +175°C (-85°F to +347°F)  
 Classes G and K: -65°C to +200°C (-85°F to +392°F)  
 Classes N and S: -65°C to +200°C (-85°F to +392°F)

### Material and Finish Data (Class)

A – aluminum shell, black anodized finish (RoHS)  
 G – stainless steel shell, passivated (RoHS)  
 K – stainless steel shell, passivated, firewall (RoHS)  
 R – aluminum shell, electroless nickel finish  
 S – stainless steel shell, passivated, firewall, and 360° teeth (RoHS)  
 W – aluminum shell, olive drab cadmium over nickel base  
 N – stainless steel shell, electrodeposited nickel, firewall, and 360° teeth

### Corrosion Resistance

Classes A, N, G, K, S & W withstand 500-hour salt spray.  
 Class R withstands 48-hour salt spray.

### Environmental Seal

Wired, mated connectors with specified accessories attached, shall meet the altitude-immersion test specified by MIL-DTL-83723 Series III.

### Fluid Resistance

Connectors resist specified immersions in MIL-PRF-7808 (lubricating oil), MIL-PRF-23699 (lubricating oil), MIL-PRF-5606 (hydraulic fluid), M2-V Chevron oil, Coolanol 25, MIL-DTL-83133 (turbine fuel JP-8), MIL-DTL-5624 (turbine fuels JP-4 and JP-5), SAE-AMS1424 Type I (defrosting fluid), and other solvents and cleaning agents.

### Voltage Rating Durability

Mated connectors withstand a minimum of 500 mating cycles for bayonet coupling straight plug (M83723/75, 76); 250 mating cycles for bayonet coupling RFI plug (M83723/77, 78); and 250 cycles for all threaded coupling plugs (M83723/86, 87, 91, 92, 95, 96, 97, 98).

### Shock and Vibration Requirements

Wired, mated connectors shall not be damaged, coupling ring shall not loosen, and there shall be no interruption of electrical continuity longer than one microsecond when subjected to the following:

#### Shock

Mated connectors withstand a pulse of approximate half sine wave of 300 G ± 15 percent magnitude with duration of 3 ± 1 milliseconds applied in three axes.

#### Vibration

Mated connectors withstand the following vibration levels:

- Random vibration per MIL-STD-1344, method 2005, test condition VI, letter J.

### Shielding Effectiveness

RFI attenuation at the specified frequency meets the requirements of MIL-DTL-83723 Series III.

- RFI shielding effectiveness of mated connectors with RFI backshells is measured in a triaxial radio frequency leakage fixture.

### Shell-to-Shell Conductivity (Except class A)

- With RFI spring fingers, the maximum potential drop shall not exceed 5 millivolts.
- Without spring fingers, the maximum potential drop shall not exceed 200 millivolts.

Service Rating	Suggested Operating Voltage*		Test Voltage	Test Voltage	Test Voltage	Test Voltage
	(Sea Level)		Sea Level	50,000 Ft.	70,000 Ft.	110,000 Ft.
	AC (RMS)	DC	V RMS	V RMS	V RMS	V RMS
I	600	850	1500	500	375	200
II	900	1250	2300	750	500	200

\* To be used by designer only as a guide.

# MIL-DTL-83723 Series III Part Number Development Bayonet Coupling



## Military and Aero-Electric Part Number Development

<b>Mil. Prefix</b>	<b>M83723/</b>	<b>71</b>	<b>R</b>	<b>12</b>	<b>12</b>	<b>N</b>	
<b>Aero Prefix</b>	<b>AE833</b>	<b>71</b>	<b>R</b>	<b>12</b>	<b>12</b>	<b>N</b>	<b>-340</b>
<b>Shell type</b>							
71 = Wall mount receptacle with socket contacts							
72 = Wall mount receptacle with pin contacts							
73 = Jam nut receptacle with socket contacts							
74 = Jam nut receptacle with pin contacts							
75 = Straight plug with socket contacts							
76 = Straight plug with pin contacts							
77 = RFI grounding plug with socket contacts							
78 = RFI grounding plug with pin contacts							
<b>Class (Material and Finish)</b>							
A = Aluminum shell, black anodized finish (not available in 77 and 78 RFI plugs)							
G = Stainless steel shell, passivated							
R = Aluminum shell, electroless nickel finish							
W = Aluminum shell, olive drab cadmium over electroless nickel finish							
<b>Shell Size (SS)</b>							
8, 10, 12, 14, 16, 18, 20, 22 or 24							
<b>Insert Arrangement</b>							
See pages 148 and 149							
<b>Polarization (Keying)</b>							
N = Normal							
6, 7, 8, 9 or Y (Alternate keyed positions, Y is not available in SS 8)							
1, 2, 3, 4 or 5 (Clocked insert polarizations within normally keyed shell, not approved for new design, n/a in shell size 8)							
<b>Modification (applies to Aero part numbers only)</b>							
01 = Less contacts (Part is bagged and tagged, but not marked with 01)							
340 = Connector kitted with M85049/31-XXX E-nut							
341 = Connector kitted with M85049/52-1-XXX straight clamp							
342 = Connector kitted with M85049/51-1-XXX right angle clamp							
Consult factory for other modifications							

83723 S III

**Note 1:** Each connector is furnished with contacts unless ordered less contacts (L/C) as follows: One spare contact for inserts requiring 2 to 26 of each contact and two spares for inserts with 27 or more of each size, and a minimum of one sealing plug up to 15% of the number of contacts of each size. In addition, one insertion/removal tool of each size is included.

**Note 2:** Proper part number marking has no “0” in front of single digit shell size (8), but it does include the “0” in front of single digit layout. Examples: M83723/72W803N and M83723/77G10056. Please note that in this series “N” for normal is included in part number marking.



**Bayonet Coupling, Crimp Removable, Rear Release**

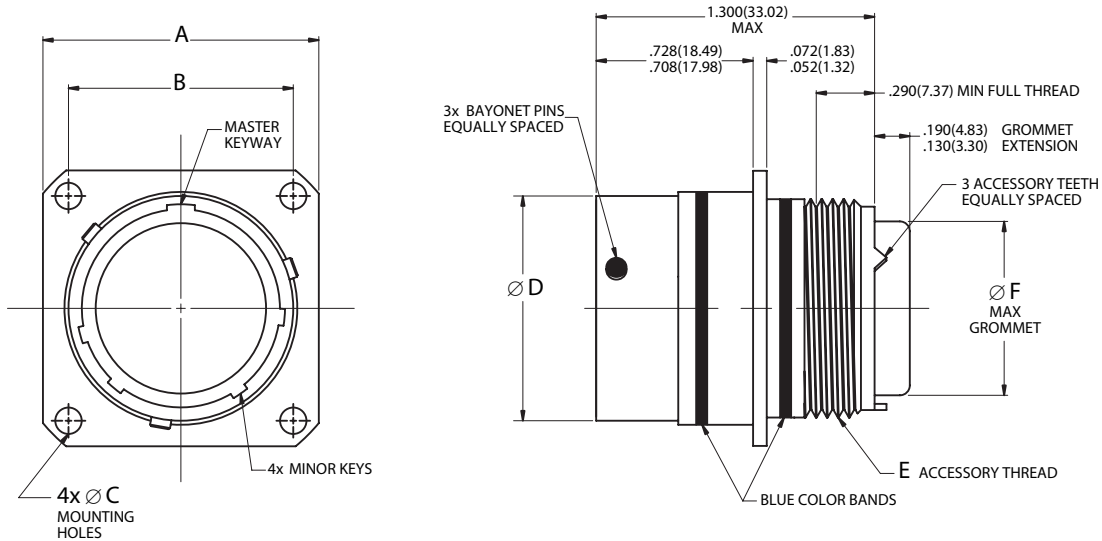

- Page 129 Completed Part Number
- Page 145 Contacts, Sealing Plugs and Tools
- Pages 148,149 Insert Arrangements
- Page 128 Performance Specifications
- Page 147 Insert Availability and Contact Information
- Page 143 Polarization

Shell Size	A		B		Ø C		Ø D		E	Ø F	
	±.005	±.13	(TP)		±.005	±.13	+0.000	+0.00	Accessory Thread Class 2A	Maximum	
	inch	mm	inch	mm	inch	mm	inch	mm		inch	mm
8	.812	20.62	.594	15.09	.120	3.05	.536	13.61	1/2-20UNF	.305	7.75
10	.937	23.80	.719	18.26	.120	3.05	.659	16.74	5/8-24UNEF	.405	10.29
12	1.031	26.19	.812	20.62	.120	3.05	.829	21.06	3/4-20UNEF	.531	13.49
14	1.125	28.58	.906	23.01	.120	3.05	.898	22.81	7/8-20UNEF	.665	16.89
16	1.250	31.75	.969	24.61	.120	3.05	1.025	26.04	1-20UNEF	.790	20.07
18	1.343	34.11	1.062	26.97	.120	3.05	1.131	28.73	1-1/16-18UNEF	.869	22.07
20	1.437	36.50	1.156	29.36	.120	3.05	1.256	31.90	1-3/16-18UNEF	.994	25.25
22	1.562	39.67	1.250	31.75	.120	3.05	1.381	35.08	1-5/16-18UNEF	1.119	28.42
24	1.703	43.26	1.375	34.93	.149	3.78	1.506	38.25	1-7/16-18UNEF	1.244	31.60

**M83723/73, 74**  
**Jam Nut Receptacle**  
**AE83373, 74**



**Bayonet Coupling, Crimp Removable, Rear Release**

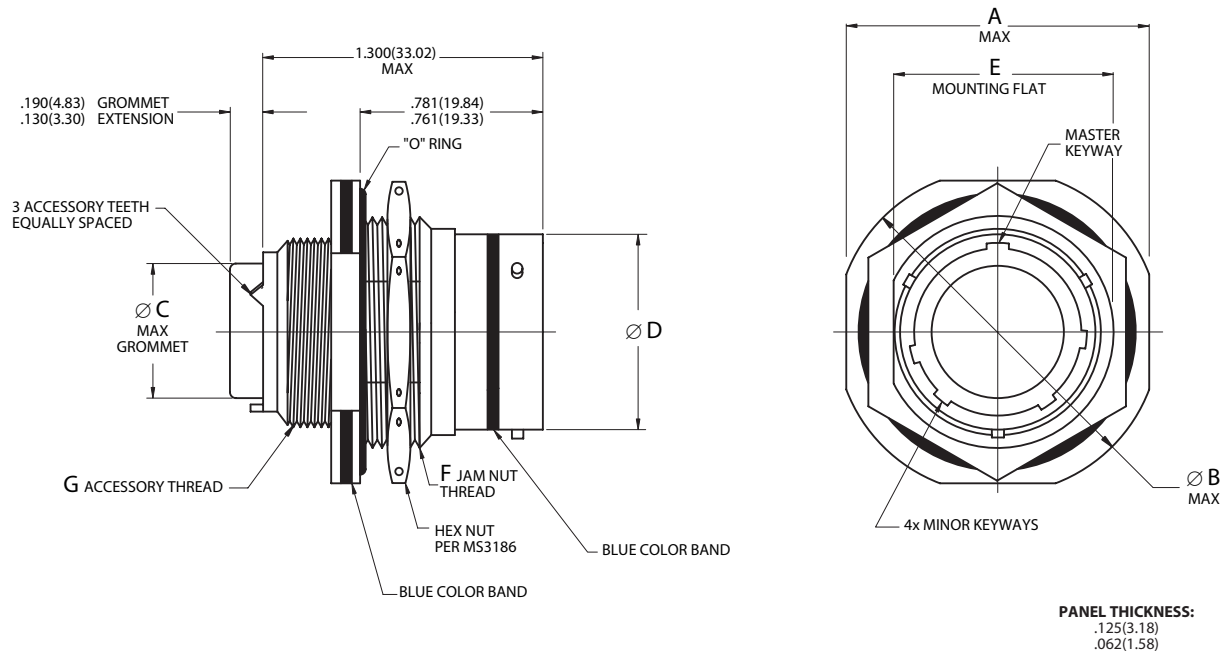

- Page 129 Completed Part Number
- Page 145 Contacts, Sealing Plugs and Tools
- Pages 148,149 Insert Arrangements
- Page 128 Performance Specifications
- Page 147 Insert Availability and Contact Information
- Page 143 Polarization

Shell Size	A		Ø B		Ø C		Ø D		E		F	G
	Maximum		Maximum		Maximum		+0.00 -0.005	+0.00 -0.13	±.003	±.08	Jam Nut Thread Class 2A	Accessory Thread Class 2A
	inch	mm	inch	mm	inch	mm	inch	mm	inch	mm		
8	.979	24.87	1.068	27.13	.305	7.75	.536	13.61	.593	15.06	5/8-20UN	1/2-20UNF
10	1.104	28.04	1.192	30.28	.405	10.29	.659	16.74	.718	18.24	3/4-20UNEF	5/8-24UNEF
12	1.291	32.79	1.380	35.05	.531	13.49	.829	21.06	.905	22.99	15/16-20UNEF	3/4-20UNEF
14	1.391	35.33	1.505	38.23	.665	16.89	.898	22.81	.968	24.59	1-20UNEF	7/8-20UNEF
16	1.516	38.51	1.630	41.40	.790	20.07	1.025	26.04	1.093	27.76	1-1/8-20UN	1-20UNEF
18	1.641	41.68	1.756	44.60	.869	22.07	1.131	28.73	1.217	30.91	1-1/4-18UNEF	1-1/16-18UNEF
20	1.766	44.86	1.860	47.24	.994	25.25	1.256	31.90	1.342	34.09	1-3/8-18UNEF	1-3/16-18UNEF
22	1.954	49.63	2.086	52.98	1.119	28.42	1.381	35.08	1.467	37.26	1-1/2-18UNEF	1-5/16-18UNEF
24	2.079	52.81	2.160	54.86	1.244	31.60	1.506	38.25	1.592	40.44	1-5/8-18UNEF	1-7/16-18UNEF

83723 S III

**Bayonet Coupling, Crimp Removable, Rear Release**

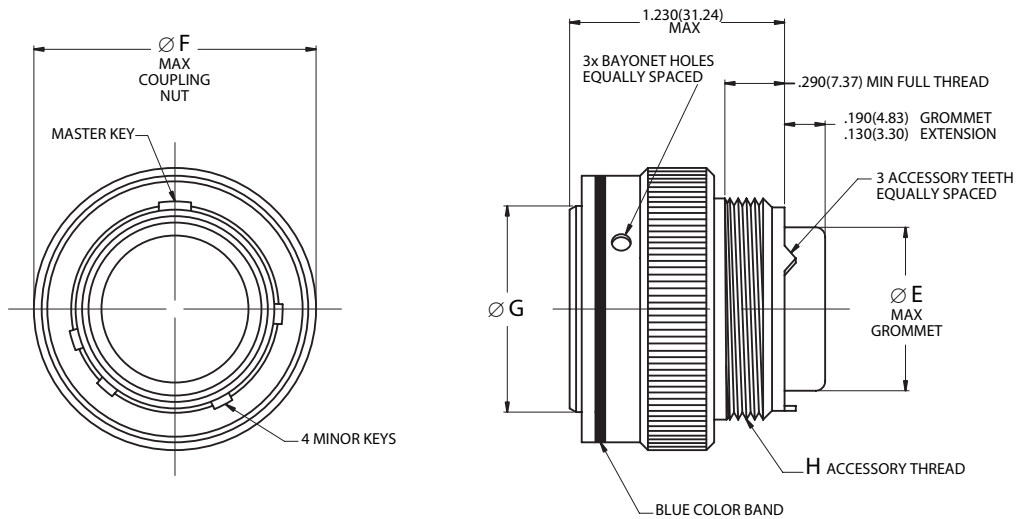

Page 129 Completed Part Number  
 Page 145 Contacts, Sealing Plugs and Tools  
 Pages 148,149 Insert Arrangements  
 Page 128 Performance Specifications  
 Page 147 Insert Availability and Contact Information  
 Page 143 Polarization

Shell Size	Ø E		Ø F		Ø G		H
	Maximum		Maximum		+0.05 -0.04	<b>+0.13</b> <b>-0.10</b>	Accessory Thread Class 2A
	inch	<b>mm</b>	inch	<b>mm</b>	inch	<b>mm</b>	
8	.305	<b>7.75</b>	.776	<b>19.71</b>	.419	<b>10.64</b>	1/2-20UNF
10	.405	<b>10.29</b>	.906	<b>23.01</b>	.521	<b>13.23</b>	5/8-24UNEF
12	.531	<b>13.49</b>	1.078	<b>27.38</b>	.691	<b>17.55</b>	3/4-20UNEF
14	.665	<b>16.89</b>	1.141	<b>28.98</b>	.760	<b>19.30</b>	7/8-20UNEF
16	.790	<b>20.07</b>	1.266	<b>32.16</b>	.887	<b>22.53</b>	1-20UNEF
18	.869	<b>22.07</b>	1.375	<b>34.93</b>	.993	<b>25.22</b>	1-1/16-18UNEF
20	.994	<b>25.25</b>	1.510	<b>38.35</b>	1.118	<b>28.40</b>	1-3/16-18UNEF
22	1.119	<b>28.42</b>	1.625	<b>41.28</b>	1.243	<b>31.57</b>	1-5/16-18UNEF
24	1.244	<b>31.60</b>	1.760	<b>44.70</b>	1.368	<b>34.75</b>	1-7/16-18UNEF



**M83723/77, 78**  
**RFI Grounding Plug**  
**AE83377, 78**



**Bayonet Coupling, Crimp Removable, Rear Release**

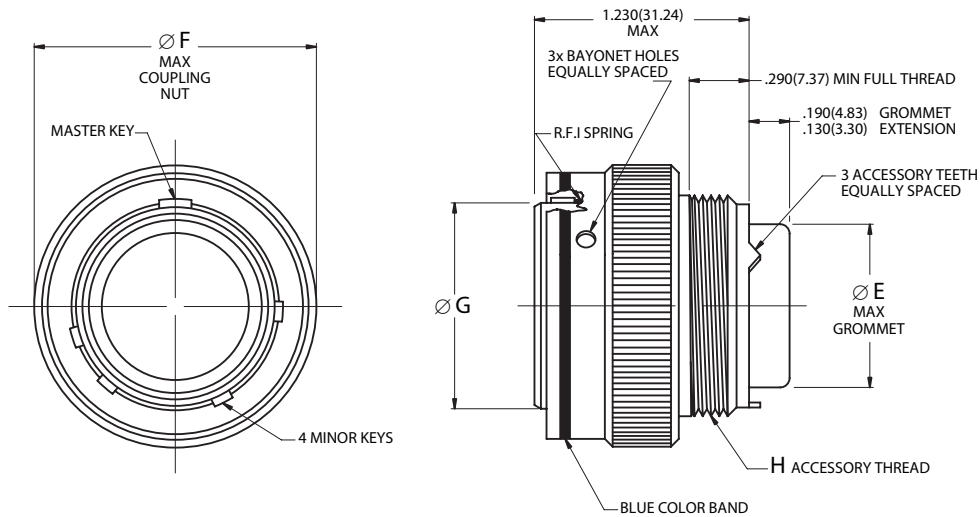

Page 129 Completed Part Number  
 Page 145 Contacts, Sealing Plugs and Tools  
 Pages 148,149 Insert Arrangements  
 Page 128 Performance Specifications  
 Page 147 Insert Availability and Contact Information  
 Page 143 Polarization

83723 S III

Shell Size	$\varnothing E$		$\varnothing F$		$\varnothing G$		H
	Maximum		Maximum		+0.05 -0.04	+0.13 -0.10	
	inch	mm	inch	mm	inch	mm	Accessory Thread Class 2A
8	.305	7.75	.776	19.71	.419	10.64	1/2-20UNF
10	.405	10.29	.906	23.01	.521	13.23	5/8-24UNEF
12	.531	13.49	1.078	27.38	.691	17.55	3/4-20UNEF
14	.665	16.89	1.141	28.98	.760	19.30	7/8-20UNEF
16	.790	20.07	1.266	32.16	.887	22.53	1-20UNEF
18	.869	22.07	1.375	34.93	.993	25.22	1-1/16-18UNEF
20	.994	25.25	1.510	38.35	1.118	28.40	1-3/16-18UNEF
22	1.119	28.42	1.625	41.28	1.243	31.57	1-5/16-18UNEF
24	1.244	31.60	1.760	44.70	1.368	34.75	1-7/16-18UNEF



# MIL-DTL-83723 Series III Part Number Development Threaded Coupling

## Military and Aero-Electric Part Number Development

<b>Mil. Prefix</b>	<b>M83723/</b>	<b>95</b>	<b>R</b>	<b>12</b>	<b>12</b>	<b>N</b>	
<b>Aero Prefix</b>	<b>AE833</b>	<b>95</b>	<b>R</b>	<b>12</b>	<b>12</b>	<b>N</b>	<b>-340</b>
<b>Shell type</b>							
82 = Wall mount receptacle with socket contacts							
83 = Wall mount receptacle with pin contacts							
84 = Jam nut receptacle with socket contacts							
85 = Jam nut receptacle with pin contacts							
86 = Straight plug with socket contacts							
87 = Straight plug with pin contacts							
91 = RFI grounding plug with socket contacts							
92 = RFI grounding plug with pin contacts							
95 = Self-locking plug with socket contacts							
96 = Self-locking plug with pin contacts							
97 = Self-locking, RFI grounding plug with socket contacts							
98 = Self-locking, RFI grounding plug with pin contacts							
68 = Lanyard release, quick-disconnect plug, pin (not available in K & S classes)							
69 = Lanyard release, quick-disconnect plug, socket (not available in K & S classes)							
<b>Class (Material and Finish)</b>							
A = Aluminum shell, black anodized finish (Not available in 91, 92, 97 & 98 RFI plugs)							
G = Stainless steel shell, passivated (n/a in 97 & 98)							
K = Stainless steel shell, passivated, with firewall rated insert (n/a in 91, 92, 97 & 98)							
R = Aluminum shell, electroless nickel finish (n/a in 97 & 98 to mil number)							
W = Aluminum shell, olive drab cadmium over nickel base (n/a in 97 & 98 to mil number)							
S = Stainless steel shell, passivated, full teeth, firewall insert (n/a in 86, 87, 91, 92, 95 & 96)							
<b>Shell Size (SS)</b>							
8, 10, 12, 14, 16, 18, 20, 22 or 24 (and shell size 28 available in Aero p/n only)							
<b>Insert Arrangement</b>							
See pages 148 and 149							
<b>Polarization (Keying)</b>							
N = Normal							
6, 7, 8, 9 or Y (Alternate keyed positions, Y is not available in SS 8)							
1, 2, 3, 4 or 5 (Clocked insert polarizations within normally keyed shell, not approved for new design, n/a in SS 8)							
<b>Modification (applies to Aero part numbers only)</b>							
01 = Less contacts (Part is bagged and tagged, but not marked with 01)							
340 = Connector kitted with M85049/31-XXX E-nut							
341 = Connector kitted with M85049/52-1-XXX straight clamp							
342 = Connector kitted with M85049/51-1-XXX right angle clamp							
Consult factory for other modifications							

83723 S III

**Note 1:** Each connector is furnished with contacts unless ordered less contacts (L/C) as follows: One spare contact for inserts requiring 2 to 26 of each contact and two spares for inserts with 27 or more of each size, and a minimum of one sealing plug up to 15% of the number of contacts of each size. In addition, one insertion/removal tool of each size is included.

**Note 2:** Proper part number marking has no “0” in front of single digit shell size (8), but it does include the “0” in front of single digit layout. Examples: M83723/95G803N and M83723/98S10056. Please note that in this series “N” for normal is included in part number marking.

**Note 3:** Shell type M83723/70 (AE83370 Receptacle Adapter) is not listed above,

**M83723/82, 83**  
**Wall Mounting Receptacle**  
**AE83382, 83**



**Threaded Coupling, Crimp Removable, Rear Release**

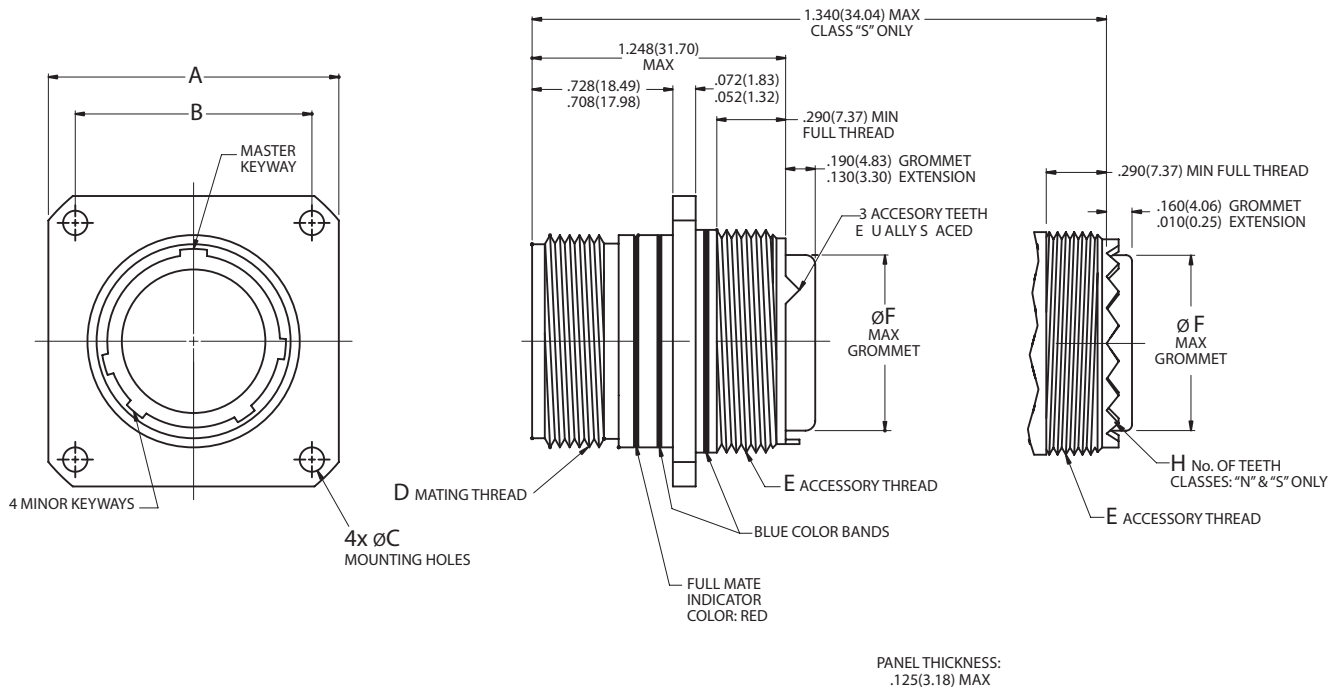

- Page 129 Completed Part Number
- Page 145 Contacts, Sealing Plugs and Tools
- Pages 148,149 Insert Arrangements
- Page 128 Performance Specifications
- Page 147 Insert Availability and Contact Information
- Page 143 Polarization

Shell Size	A		B		Ø C		D	E	Ø F		H
	±.005	±.13	(TP)		+.005	+.13	Mating Thread	Accessory Thread	Maximum		No. of Teeth
	inch	mm	inch	mm	inch	mm	Class 2A	Class 2A	inch	mm	
8	.812	20.62	.594	15.09	.120	3.05	9/16-24UNEF	1/2-20UNF	.305	7.75	12
10	.937	23.80	.719	18.26	.120	3.05	11/16-24UNEF	5/8-24UNEF	.405	10.29	15
12	1.031	26.19	.812	20.62	.120	3.05	7/8-20UNEF	3/4-20UNEF	.531	13.49	21
14	1.125	28.58	.906	23.01	.120	3.05	15/16-20UNEF	7/8-20UNEF	.665	16.89	24
16	1.250	31.75	.969	24.61	.120	3.05	1-1/16-18UNEF	1-20UNEF	.790	20.07	30
18	1.343	34.11	1.062	26.97	.120	3.05	1-3/16-18UNEF	1-1/16-18UNEF	.869	22.07	33
20	1.437	36.50	1.156	29.36	.120	3.05	1-5/16-18UNEF	1-3/16-18UNEF	.994	25.25	36
22	1.562	39.67	1.250	31.75	.120	3.05	1-7/16-18UNEF	1-5/16-18UNEF	1.119	28.42	39
24	1.703	43.26	1.375	34.93	.149	3.78	1-9/16-18UNEF	1-7/16-18UNEF	1.244	31.60	42
28	2.000	50.80	1.562	39.67	.149	3.78	1-13/16-16UN	1-3/4-18UNS	1.475	37.47	54

83723 S III

**Threaded Coupling, Crimp Removable, Rear Release**

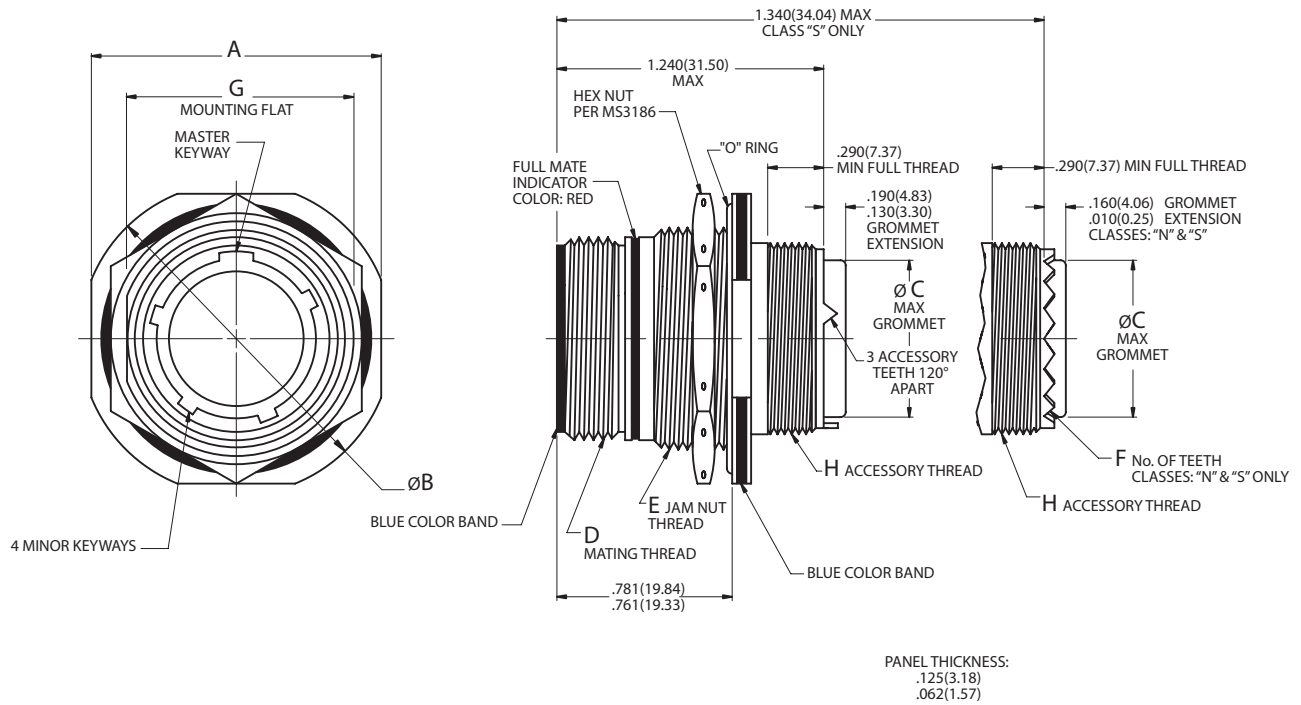

PANEL THICKNESS:  
 .125(3.18)  
 .062(1.57)

- Page 129 Completed Part Number
- Page 145 Contacts, Sealing Plugs and Tools
- Pages 148,149 Insert Arrangements
- Page 128 Performance Specifications
- Page 147 Insert Availability and Contact Information
- Page 143 Polarization

Shell Size	A		Ø B		Ø C		D	E	F	G		H
	+0.016 -0.015	<b>+0.41</b> <b>-0.38</b>	+0.016 -0.015	<b>+0.41</b> <b>-0.38</b>	Maximum		Mating Thread Class 2A	Jam Nut Thread Class 2A	No. of Teeth	±0.003	<b>±0.08</b>	Accessory Thread
	inch	<b>mm</b>	inch	<b>mm</b>	inch	<b>mm</b>				inch	<b>mm</b>	Class 2A
8	.964	<b>24.49</b>	1.062	<b>26.97</b>	.305	<b>7.75</b>	9/16-24UNEF	5/8-20UN	12	.593	<b>15.06</b>	1/2-20UNF
10	1.088	<b>27.64</b>	1.176	<b>29.87</b>	.405	<b>10.29</b>	11/16-24UNEF	3/4-20UNEF	15	.718	<b>18.24</b>	5/8-24UNEF
12	1.275	<b>32.39</b>	1.364	<b>34.65</b>	.531	<b>13.49</b>	7/8-20UNEF	15/16-20UNEF	21	.905	<b>22.99</b>	3/4-20UNEF
14	1.375	<b>34.93</b>	1.545	<b>39.24</b>	.665	<b>16.89</b>	15/16-20UNEF	1-20UNEF	24	.968	<b>24.59</b>	7/8-20UNEF
16	1.500	<b>38.10</b>	1.625	<b>41.28</b>	.790	<b>20.07</b>	1-1/16-18UNEF	1-1/8-18UNEF	30	1.093	<b>27.76</b>	1-20UNEF
18	1.625	<b>41.28</b>	1.750	<b>44.45</b>	.869	<b>22.07</b>	1-3/16-18UNEF	1-1/4-18UNEF	33	1.217	<b>30.91</b>	1-1/16-18UNEF
20	1.750	<b>44.45</b>	1.938	<b>49.23</b>	.994	<b>25.25</b>	1-5/16-18UNEF	1-3/8-18UNEF	36	1.342	<b>34.09</b>	1-3/16-18UNEF
22	1.938	<b>49.23</b>	2.062	<b>52.37</b>	1.119	<b>28.42</b>	1-7/16-18UNEF	1-1/2-18UNEF	39	1.467	<b>37.26</b>	1-5/16-18UNEF
24	2.063	<b>52.40</b>	2.166	<b>55.02</b>	1.244	<b>31.60</b>	1-9/16-18UNEF	1-5/8-18UNEF	42	1.592	<b>40.44</b>	1-7/16-18UNEF
28	2.314	<b>58.78</b>	2.428	<b>61.67</b>	1.475	<b>37.47</b>	1-13/16-16UN	1-7/8-20UN	54	1.840	<b>46.74</b>	1-3/4-18UNS

**M83723/86, 87**  
**Straight Plug**  
**AE83386, 87**



**Threaded Coupling, Crimp Removable, Rear Release**

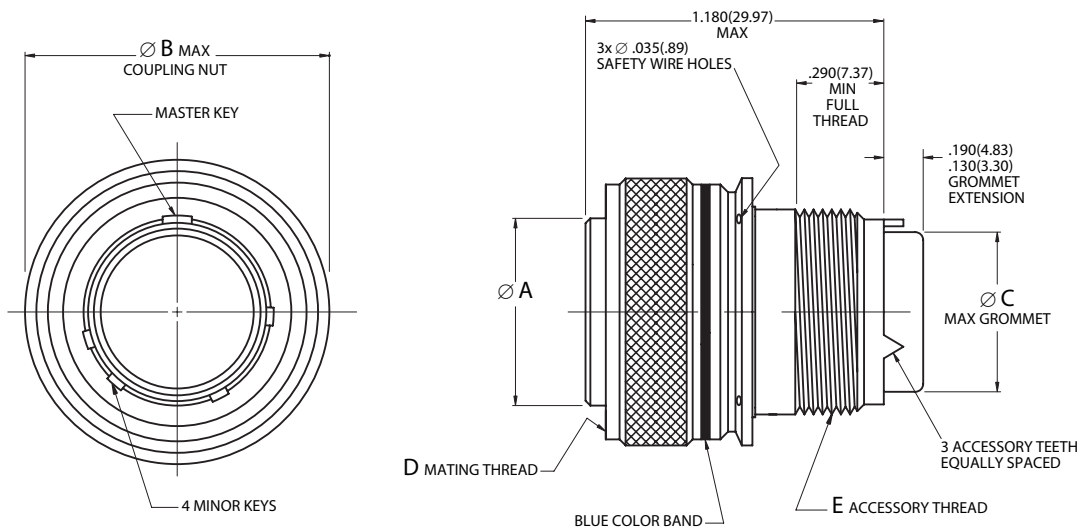

Page 129 Completed Part Number  
 Page 145 Contacts, Sealing Plugs and Tools  
 Pages 148,149 Insert Arrangements  
 Page 128 Performance Specifications  
 Page 147 Insert Availability and Contact Information  
 Page 143 Polarization

Shell Size	$\varnothing A$		$\varnothing B$		$\varnothing C$		D	E
	+0.005 -0.004	<b>+.13 -.10</b>	Maximum		Maximum		Mating Thread Class 2B	Accessory Thread Class 2A
	inch	<b>mm</b>	inch	<b>mm</b>	inch	<b>mm</b>		
8	.400	<b>10.16</b>	.776	<b>19.71</b>	.305	<b>7.75</b>	9/16-24UNEF	1/2-20UNF
10	.521	<b>13.23</b>	.906	<b>23.01</b>	.405	<b>10.29</b>	11/16-24UNEF	5/8-24UNEF
12	.691	<b>17.55</b>	1.078	<b>27.38</b>	.531	<b>13.49</b>	7/8-20UNEF	3/4-20UNEF
14	.760	<b>19.30</b>	1.141	<b>28.98</b>	.665	<b>16.89</b>	15/16-20UNEF	7/8-20UNEF
16	.887	<b>22.53</b>	1.266	<b>32.16</b>	.790	<b>20.07</b>	1-1/16-18UNEF	1-20UNEF
18	.993	<b>25.22</b>	1.375	<b>34.93</b>	.869	<b>22.07</b>	1-3/16-18UNEF	1-1/16-18UNEF
20	1.118	<b>28.40</b>	1.510	<b>38.35</b>	.994	<b>25.25</b>	1-5/16-18UNEF	1-3/16-18UNEF
22	1.243	<b>31.57</b>	1.625	<b>41.28</b>	1.119	<b>28.42</b>	1-7/16-18UNEF	1-5/16-18UNEF
24	1.368	<b>34.75</b>	1.760	<b>44.70</b>	1.244	<b>31.60</b>	1-9/16-18UNEF	1-7/16-18UNEF
28	1.618	<b>41.10</b>	2.050	<b>52.07</b>	1.475	<b>37.47</b>	1-13/16-16UN	1-3/4-18UNS

83723 S III

**Threaded Coupling, Crimp Removable, Rear Release**

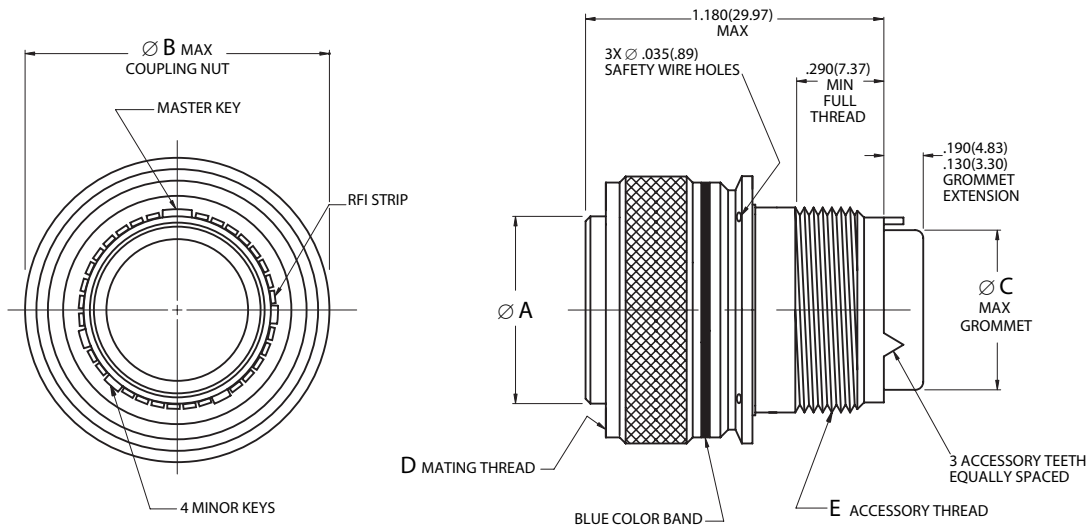

Page 129 Completed Part Number  
 Page 145 Contacts, Sealing Plugs and Tools  
 Pages 148,149 Insert Arrangements  
 Page 128 Performance Specifications  
 Page 147 Insert Availability and Contact Information  
 Page 143 Polarization

Shell Size	Ø A		Ø B		Ø C		D	E
	+0.005	<b>+.13</b>	Maximum		Maximum		Mating Thread	Accessory Thread
	-.004	<b>-.10</b>	inch	mm	inch	mm	Class 2B	Class 2A
8	.400	<b>10.16</b>	.776	<b>19.71</b>	.305	<b>7.75</b>	9/16-24UNEF	1/2-20UNF
10	.521	<b>13.23</b>	.906	<b>23.01</b>	.405	<b>10.29</b>	11/16-24UNEF	5/8-24UNEF
12	.691	<b>17.55</b>	1.078	<b>27.38</b>	.531	<b>13.49</b>	7/8-20UNEF	3/4-20UNEF
14	.760	<b>19.30</b>	1.141	<b>28.98</b>	.665	<b>16.89</b>	15/16-20UNEF	7/8-20UNEF
16	.887	<b>22.53</b>	1.266	<b>32.16</b>	.790	<b>20.07</b>	1-1/16-18UNEF	1-20UNEF
18	.993	<b>25.22</b>	1.375	<b>34.93</b>	.869	<b>22.07</b>	1-3/16-18UNEF	1-1/16-18UNEF
20	1.118	<b>28.40</b>	1.510	<b>38.35</b>	.994	<b>25.25</b>	1-5/16-18UNEF	1-3/16-18UNEF
22	1.243	<b>31.57</b>	1.625	<b>41.28</b>	1.119	<b>28.42</b>	1-7/16-18UNEF	1-5/16-18UNEF
24	1.368	<b>34.75</b>	1.760	<b>44.70</b>	1.244	<b>31.60</b>	1-9/16-18UNEF	1-7/16-18UNEF
28	1.618	<b>41.10</b>	2.050	<b>52.07</b>	1.475	<b>37.47</b>	1-13/16-16UN	1-3/4-18UNS

**M83723/95, 96**  
**Self-Locking Plug**  
**AE83395, 96**



**Threaded Coupling, Crimp Removable, Rear Release**

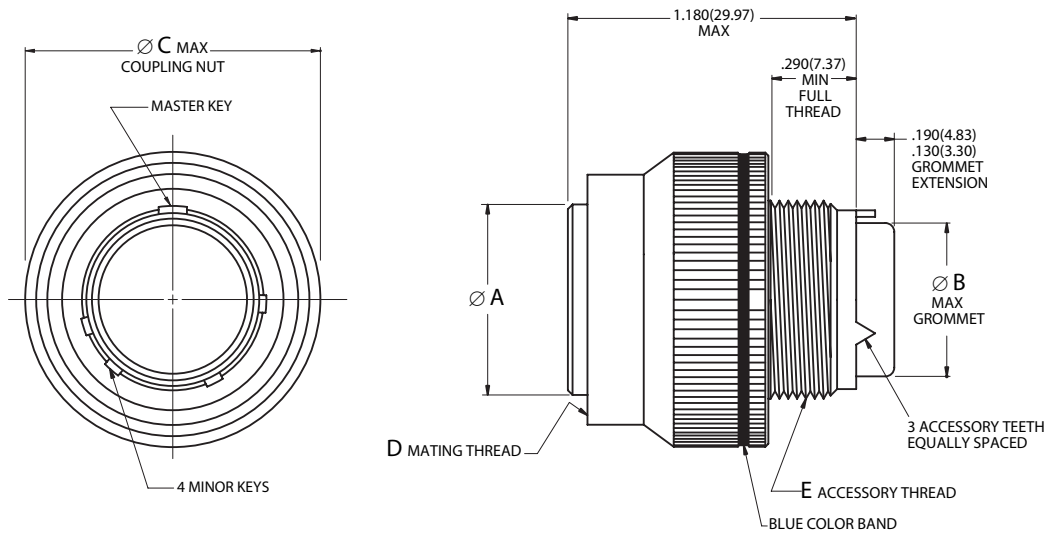

- Page 129 Completed Part Number
- Page 145 Contacts, Sealing Plugs and Tools
- Pages 148,149 Insert Arrangements
- Page 128 Performance Specifications
- Page 147 Insert Availability and Contact Information
- Page 143 Polarization

Shell Size	Ø A		Ø B		Ø C		D	E
	+0.005	<b>+13</b>	Maximum	Maximum	Maximum	Maximum	Mating Thread Class 2B	Accessory Thread Class 2A
	-.004	<b>-10</b>						
	inch	<b>mm</b>	inch	<b>mm</b>	inch	<b>mm</b>		
8	.400	<b>10.16</b>	.305	<b>7.75</b>	.832	<b>21.13</b>	9/16-24UNEF	1/2-20UNF
10	.521	<b>13.23</b>	.405	<b>10.29</b>	.959	<b>24.36</b>	11/16-24UNEF	5/8-24UNEF
12	.691	<b>17.55</b>	.531	<b>13.49</b>	1.097	<b>27.86</b>	7/8-20UNEF	3/4-20UNEF
14	.760	<b>19.30</b>	.665	<b>16.89</b>	1.236	<b>31.39</b>	15/16-20UNEF	7/8-20UNEF
16	.887	<b>22.53</b>	.790	<b>20.07</b>	1.360	<b>34.54</b>	1-1/16-18UNEF	1-20UNEF
18	.993	<b>25.22</b>	.869	<b>22.07</b>	1.473	<b>37.41</b>	1-3/16-18UNEF	1-1/16-18UNEF
20	1.118	<b>28.40</b>	.994	<b>25.25</b>	1.586	<b>40.28</b>	1-5/16-18UNEF	1-3/16-18UNEF
22	1.243	<b>31.57</b>	1.119	<b>28.42</b>	1.703	<b>43.26</b>	1-7/16-18UNEF	1-5/16-18UNEF
24	1.368	<b>34.75</b>	1.244	<b>31.60</b>	1.846	<b>46.89</b>	1-9/16-18UNEF	1-7/16-18UNEF
28	1.618	<b>41.10</b>	1.475	<b>37.47</b>	2.278	<b>57.86</b>	1-13/16-16UN	1-3/4-18UNS

83723 S III

**Threaded Coupling, Crimp Removable, Rear Release**

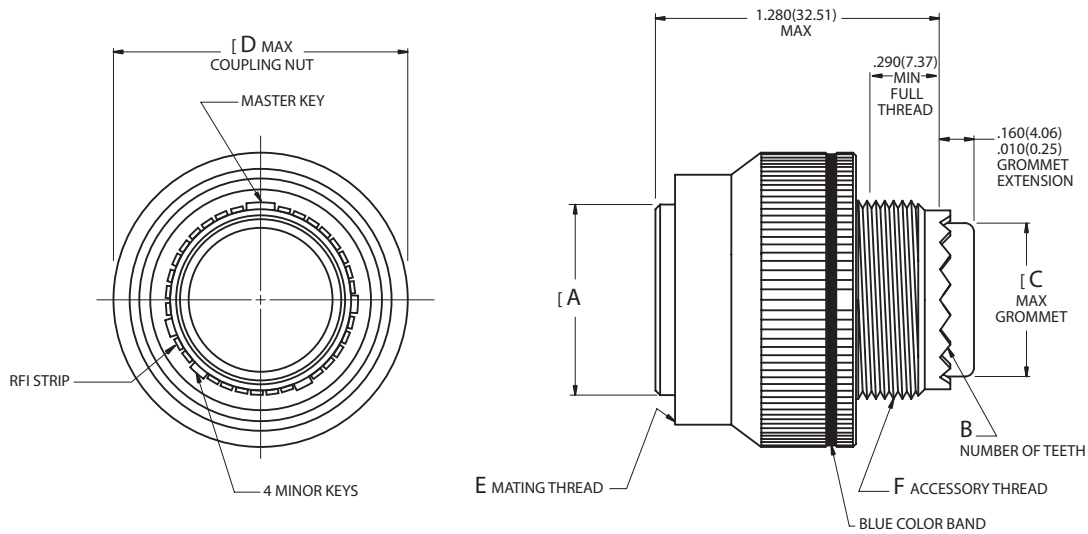

Page 129 Completed Part Number  
 Page 145 Contacts, Sealing Plugs and Tools  
 Pages 148,149 Insert Arrangements  
 Page 128 Performance Specifications  
 Page 147 Insert Availability and Contact Information  
 Page 143 Polarization

Shell Size	Ø A		B	Ø C		Ø D		E	F
	+0.005	<b>+13</b>	No. of	Maximum		Maximum		Mating Thread	Accessory Thread
	-0.004	<b>-10</b>	Teeth	inch	mm	inch	mm	Class 2B	Class 2A
8	.400	<b>10.16</b>	12	.305	<b>7.75</b>	.967	<b>24.56</b>	9/16-24UNEF	1/2-20UNF
10	.521	<b>13.23</b>	15	.405	<b>10.29</b>	1.093	<b>27.76</b>	11/16-24UNEF	5/8-24UNEF
12	.691	<b>17.55</b>	21	.531	<b>13.49</b>	1.170	<b>29.72</b>	7/8-20UNEF	3/4-20UNEF
14	.760	<b>19.30</b>	24	.665	<b>16.89</b>	1.310	<b>33.27</b>	15/16-20UNEF	7/8-20UNEF
16	.887	<b>22.53</b>	30	.790	<b>20.07</b>	1.500	<b>38.10</b>	1-1/16-18UNEF	1-20UNEF
18	.993	<b>25.22</b>	33	.869	<b>22.07</b>	1.562	<b>39.67</b>	1-3/16-18UNEF	1-1/16-18UNEF
20	1.118	<b>28.40</b>	36	.994	<b>25.25</b>	1.710	<b>43.43</b>	1-5/16-18UNEF	1-3/16-18UNEF
22	1.243	<b>31.57</b>	39	1.119	<b>28.42</b>	1.812	<b>46.02</b>	1-7/16-18UNEF	1-5/16-18UNEF
24	1.368	<b>34.75</b>	42	1.244	<b>31.60</b>	1.948	<b>49.48</b>	1-9/16-18UNEF	1-7/16-18UNEF
28	1.618	<b>41.10</b>	54	1.475	<b>37.47</b>	2.278	<b>57.86</b>	1-13/16-16UN	1-3/4-18UNS



**M83723/68, 69**  
**Lanyard Release, Quick-Disconnect Plug**  
**AE83368, 69**



**Quick-Disconnect, Threaded Coupling, Crimp Removable, Rear Release**

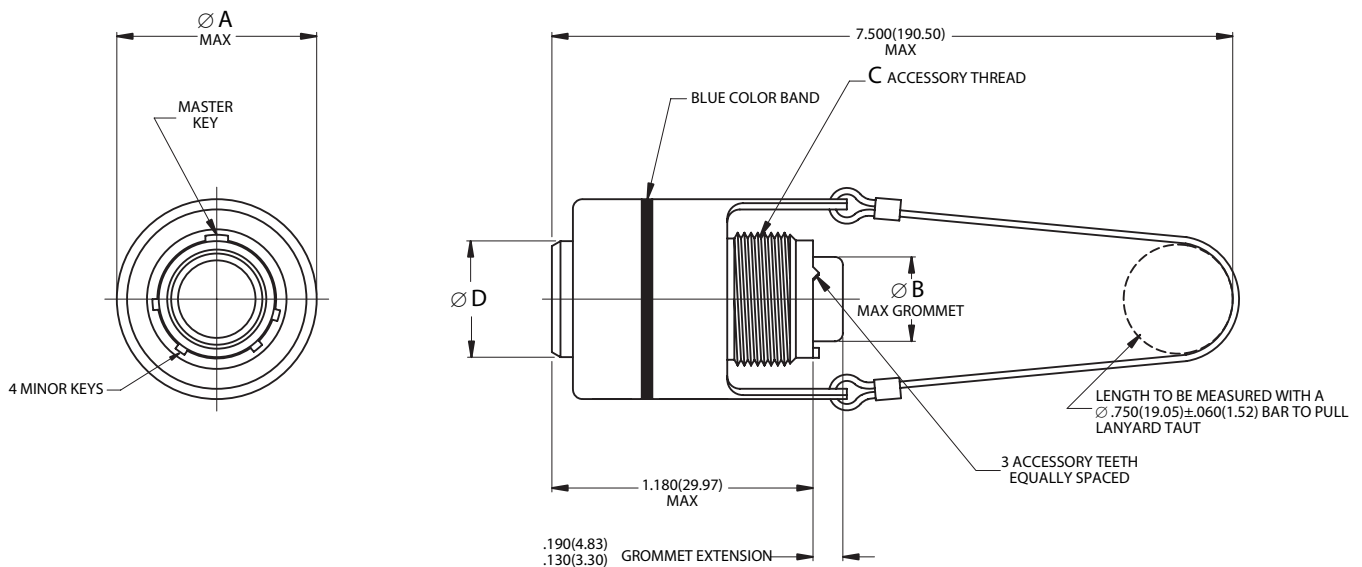

Page 129	Completed Part Number
Page 145	Contacts, Sealing Plugs and Tools
Pages 148,149	Insert Arrangements
Page 128	Performance Specifications
Page 147	Insert Availability and Contact Information
Page 143	Polarization

**Note 1:** M83723/70 receptacle adapter (page 142) is required to mate the Quick-Disconnect Plug with a receptacle.

**Note 2:** Not available in shell size 8.

Shell Size	$\varnothing A$		$\varnothing B$		C Accessory Thread Class 2A	$\varnothing D$	
	Maximum		Maximum			inch	mm
	inch	mm	inch	mm			
10	1.240	31.50	.405	10.29	5/8-24UNEF	.526/.517	13.36/13.13
12	1.432	36.37	.531	13.49	3/4-20UNEF	.696/.687	17.68/17.45
14	1.490	37.85	.665	16.89	7/8-20UNEF	.765/.756	19.43/19.20
16	1.711	43.46	.790	20.07	1-20UNEF	.892/.883	22.66/22.43
18	1.815	46.10	.869	22.07	1-1/16-18UNEF	.998/.989	25.35/25.12
20	1.962	49.83	.994	25.25	1-3/16-18UNEF	1.123/1.114	28.52/28.30
22	2.070	52.58	1.119	28.42	1-5/16-18UNEF	1.248/1.239	31.70/31.47
24	2.195	55.75	1.244	31.60	1-7/16-18UNEF	1.373/1.364	34.87/34.65



**M83723/70**

**Receptacle Adapter, Quick-Disconnect**

**AE83370**

**Quick-Disconnect (Push-Pull) Receptacle Adapter**

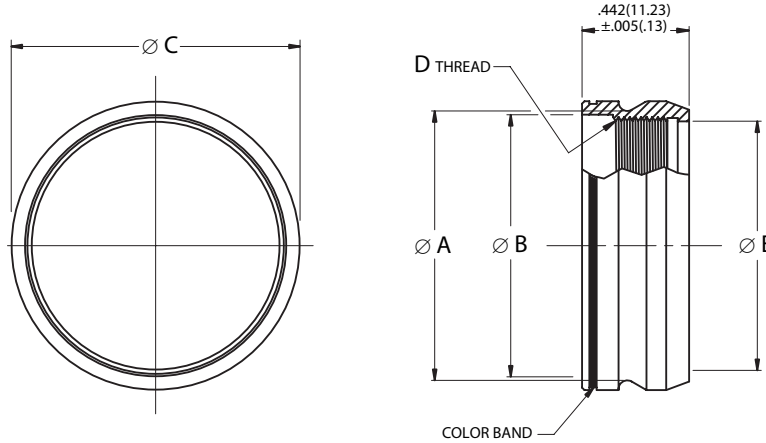

<b>Mil Prefix</b>	<b>M83723/</b>	<b>70</b>	<b>W</b>	<b>10</b>
<b>Aero Prefix</b>	<b>AE833</b>	<b>70</b>	<b>W</b>	<b>10</b>
<b>Specification Sheet (Shell type)</b>				
70 = Receptacle adapter, quick-disconnect				
<b>Class (Material and Finish)</b>				
A = Aluminum shell, black anodized finish				
G = Stainless steel shell, passivated				
R = Aluminum shell, electroless nickel finish				
W = Aluminum shell, cadmium olive drab over nickel base				
<b>Shell Size</b>				
8, 10, 12, 14, 16, 18, 20, 22 or 24				

**Note:** The adapter is required to mate the Lanyard Release and Push-Pull Quick-Disconnect plugs (M83723/66 thru 69) with M83723/82, 83, 84, 85, 88, 89 and 90 threaded coupling receptacles. Use compatible thread seizing compound to permanently secure to the receptacle.

Shell Size	D	Ø A		Ø B		Ø C		Ø E	
	Coupling Thread Class 2B	±.002	±.05	±.002	±.05	±.002	±.05	±.005	±.13
		inch	mm	inch	mm	inch	mm	inch	mm
8	9/16-24UNEF	.605	15.37	.577	14.66	.687	17.45	.525	13.34
10	11/16-24UNEF	.730	18.54	.712	18.08	.812	20.62	.650	16.51
12	7/8-20UNEF	.917	23.29	.892	22.66	.999	25.37	.840	21.34
14	15/16-20UNEF	.980	24.89	.952	24.18	1.062	26.97	.900	22.86
16	1-1/16-18UNEF	1.105	28.07	1.077	27.36	1.187	30.15	1.025	26.04
18	1-3/16-18UNEF	1.230	31.24	1.202	30.53	1.328	33.73	1.150	29.21
20	1-5/16-18UNEF	1.355	34.42	1.327	33.71	1.453	36.91	1.275	32.39
22	1-7/16-18UNEF	1.480	37.59	1.452	36.88	1.578	40.08	1.400	35.56
24	1-9/16-18UNEF	1.605	40.77	1.577	40.06	1.703	43.26	1.525	38.74

83723 S III

# MIL-DTL-83723 Series III Polarization (Shell Keying, Insert Clocking) Bayonet and Threaded



## Shell Keying

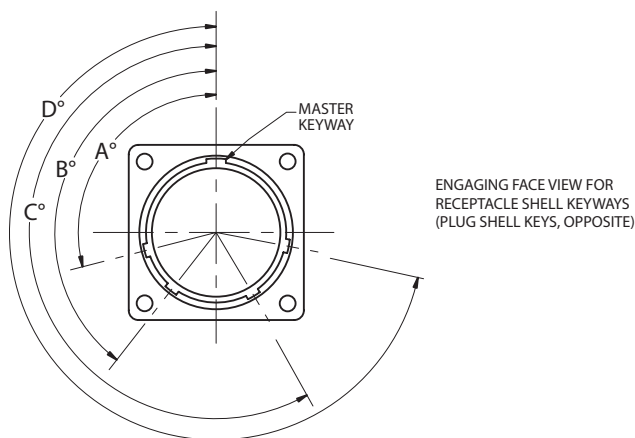

## Insert Clocking

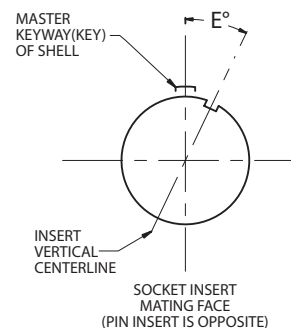

### Notes:

1. In the normal position (N), the insert centerline coincides with the centerline of the master keyway (key) of the shell.  $E = 0^\circ$
2. In the alternate keying positions (6, 7, 8, 9 and Y), the minor keyways (keys) are positioned with reference to master keyway (key) as indicated in the keying position table below.
3. In the alternate insert clocking positions (1, 2, 3, 4 and 5), the socket insert (viewing from the mating side) is rotated counter-clockwise relative to the centerline of the master keyway (key) of the shell. The pin insert is rotated clockwise.

Shell Size	Polarizing		Key/Keyway Positions				Insert Position	
	Position	A°	B°	C°	D°	E°		
8*, 10	N	105	140	215	265	0		
	6	102	132	248	320	0		
	7	80	118	230	312	0		
	8	35	140	205	275	0		
	9	64	155	234	304	0		
10 only	Y	25	115	220	270	0		
12 thru 24, 28**	N	105	140	215	265	0		
	6	18	149	192	259	0		
	7	92	152	222	342	0		
	8	84	152	204	334	0		
	9	24	135	199	240	0		
	Y	98	152	268	338	0		
10 thru 24	1†	105	140	215	265	10		
	2†	105	140	215	265	20		
	3†	105	140	215	265	30		
	4†	105	140	215	265	40		
	5†	105	140	215	265	50		

\* Per MIL-STD-1554, keyed position Y and clocked positions 1, 2, 3, 4 and 5 are not available in shell size 8.

\*\* Shell size 28 is not from military standard. It is only available in threaded family to Aero-Electric part number.

† Per MIL-STD-1554, insert positions 1 thru 5 are inactive for new design.

**Note:** Alternate positions “Z” and “10” are cancelled and superseded by Position “Y”.

## Panel Cutouts

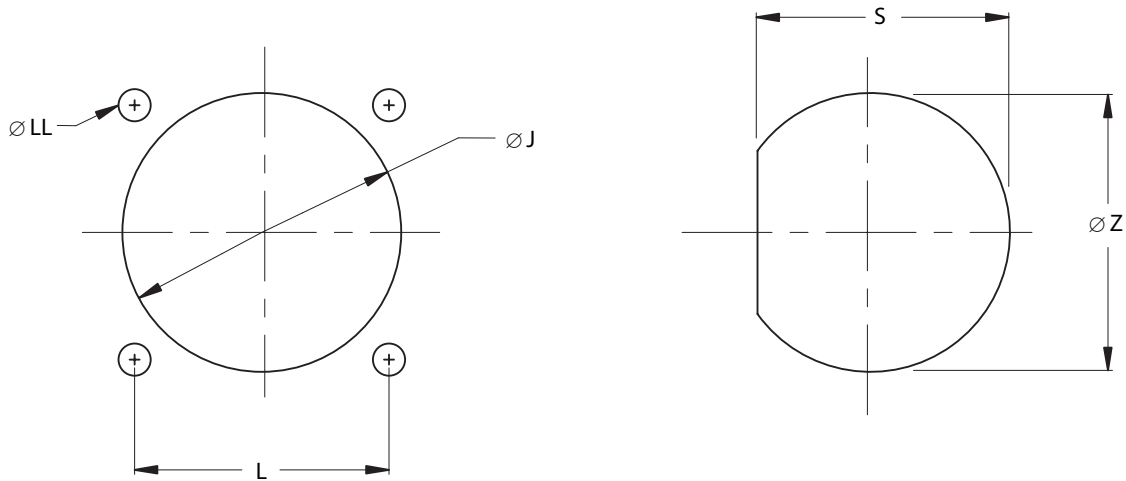

### Panel Thickness

Receptacle Type	Rear Mounting		Front Mounting	
	inch	mm	inch	mm
Wall Mount Receptacle, Bayonet	.250 max*	6.36 max*	.125 max	3.18 max
Wall Mount Receptacle, Threaded	.125 max	3.18 max	.125 max	3.18 max
Jam Nut Mount (Bayonet & Threaded)	.062/.125	1.57/3.18	—	—

\* Includes screw-head

### Flange and Jam Nut Mounting Dimensions

Shell Size	L		Ø J		Ø J		Ø LL		S		Ø Z	
	(TP)		For Back Mounting Minimum		For Front Mounting Minimum		+0.000	+0.00	±.005	±.13	±.005	±.13
	inch	mm	inch	mm	inch	mm	inch	mm	inch	mm	inch	mm
8	.594	15.09	.620	15.75	.510	12.95	.125	3.18	.605	15.37	.635	16.13
10	.719	18.26	.748	19.00	.635	16.13	.125	3.18	.730	18.54	.760	19.30
12	.812	20.62	.918	23.32	.760	19.30	.125	3.18	.917	23.29	.947	24.05
14	.906	23.01	.988	25.10	.885	22.48	.125	3.18	.980	24.89	1.010	25.65
16	.969	24.61	1.114	28.30	1.010	25.65	.125	3.18	1.105	28.07	1.135	28.83
18	1.062	26.97	1.220	30.99	1.072	27.23	.125	3.18	1.229	31.22	1.260	32.00
20	1.156	29.36	1.346	34.19	1.197	30.40	.125	3.18	1.354	34.39	1.385	35.18
22	1.250	31.75	1.470	37.34	1.322	33.58	.125	3.18	1.479	37.57	1.510	38.35
24	1.375	34.93	1.596	40.54	1.442	36.63	.154	3.91	1.604	40.74	1.635	41.53

**MIL-DTL-83723****Contacts, Tools and Seal Plugs  
Series III****Contacts, Plastic Insertion/Removal Tools and Seal Plugs**

	Application	Pin Contacts	Socket Contacts	Seal Plugs	Insertion/Removal Tools
Contact Size					Plastic
	Type	Military No.	Military No.	Military No.	Military No.
20	Power/Signal	M39029/4-110	M39029/5-115	MS27488-20-1	M81969/14-11
16	Power/Signal	M39029/4-111	M39029/5-116	MS27488-16-1	M81969/14-03
12	Power/Signal	M39029/4-113	M39029/5-118	MS27488-12-1	M81969/14-04

**Crimping and Metal Insertion/Extraction Tools**

	Crimp Tool	Positioner	Positioner	Insertion Tool	Extraction Tool
Contact Size		For Pin Contacts	For Socket Contacts	Metal	Metal
	Military No.	Military No.	Military No.	Military No.	Military No.
20	M22520/1-01	M22520/1-02	M22520/1-02	M81969/8-205	M81969/8-206
	M22520/2-01	M22520/2-02	M22520/2-02		
16	M22520/1-01	M22520/1-02	M22520/1-02	M81969/8-207	M81969/8-208
12	M22520/1-01	M22520/1-02	M22520/1-02	M81969/8-209	M81969/8-210

**Contact and Wire Data**

Contact Size	Test Current	Voltage	Crimp Well Data			Wire Range	Finished Wire Ø Range				
	DC Test	Max. Drop	Well Dia.	Minimum Well Dept			Minimum		Maximum		
	Amps	Millivolts	inch	inch	mm	AWG	mm <sup>2</sup>	inch	mm	inch	mm
20	7.5	55	.049 ±.001	.155	3.94	24-20	.20-.52	.040	1.02	.083	2.11
16	13.0	49	.067 ±.001	.250	6.35	20-16	.52-1.31	.053	1.35	.103	2.62
12	23.0	42	.100 ±.002	.250	6.35	14-12	2.08-3.31	.097	2.46	.158	4.01

**Note:** Test Current and Maximum Voltage Drop when tested with silver-plated wire at 25°C.



## MIL-DTL-83723 Series III Contact Installation Instructions Bayonet and Threaded Coupling

### Contact Installation Instructions

#### Crimping Contacts

1. Select the appropriate crimp tool and ensure that the proper crimp head positioner is used.
2. Cycle the tool to be sure the indentors are open.
3. Determine the correct selector setting for the wire size from the data plate on the positioner (turret head assembly) and set the selector knob on the crimp tool to match.
4. Place the contact, mating end first, into the tool.
5. Insert the stripped wire into the hollow end of the contact. Be sure the wire is inserted as far as it will go.
6. Close the tool completely to crimp. Unless the tool is closed completely, the tool will not release the contact.
7. Remove the crimped contact from the tool. Check the inspection hole to verify that the wire is fully inserted.

#### Insertion of Contacts

1. Before inserting the contacts, unscrew the accessories (clamps, backshells or adapters) from rear of plug or receptacle. Slide the hardware over the wire bundle in the proper order for reassembly after all the contacts are inserted.
2. To assist insertion of contacts, lubricate insulator (grommet) cavities with isopropyl alcohol. Alcohol will evaporate and will not leave a conductive film. **Caution: Never use any lubricant other than isopropyl alcohol.**

3. Place the correct insertion tool on the contact so that the wire runs along the groove in the tool. (Tool tip will butt against the shoulder.) Hold the plug or receptacle body firmly.
4. Beginning with a center cavity, insert the contact into the insulator with a slow, even pressure until the contact snaps into position. Make sure the contact and tool are held perpendicular to the face of the insert during the contact installation or the grommet could be damaged.
  - 4.1 If contacts are not inserted all the way prior to removing insertion tool, do not try to reinsert the insertion tool. Instead, remove the contact and try again; otherwise reinserting the insertion tool may damage the inside of the contact cavity.
5. Remove tool and check the face of the connector for proper contact installation. Proper installation may also be checked by pulling back lightly on the wire to make sure the contact is properly seated.

#### Completion

After all the cavities have been filled, slide the hardware back into position on the connector and tighten.

#### Extraction of Contacts (Rework)

1. Slide the hardware back over the wire bundle.
2. Select the appropriate tool. Place the wire into the extraction tool of the pin or socket.
3. Slowly slide the extraction tool down wire into the contact cavities until the tool tip bottoms against the contact shoulder, expanding the clip retaining tines. Hold the wire firmly in the tool and pull the wired contact and tool straight out of the rear of the insulator.

Size	Pin Contact	Socket Contact	Basic Crimp Tool	Pin Positioner	Socket Positioner	Insertion/Removal Tool
20	M39029/4-110	M39029/5-115	M22520/1-01	M22520/1-02 Red	M22520/1-02 Red	M81969/14-11
			M22520/2-01	M22520/2-02	M22520/2-02	
16	M39029/4-111	M39029/5-116	M22520/1-01	M22520/1-02 Blue	M22520/1-02 Blue	M81969/14-03
12	M39029/4-113	M39029/5-118	M22520/1-01	M22520/1-02 Yellow	M22520/1-02 Yellow	M81969/14-04

**MIL-DTL-83723 Series III**  
**Insert Availability and Contact Information**  
**per MIL-STD-1554**



**Insert Availability and Contact Information**

Insert Arrangement	Aero-Electric		Total	Quantity of Contacts				Service	Alternate Positions**				
	Status		No. of	(by Size)					(Insert Rotation in Degrees)				
	QPL'd	Tooled	Contacts	20	16	12	# 8 coax	Rating	1	2	3	4	5
8-2Δ	Yes	Yes	2	2				I	N/A	N/A	N/A	N/A	N/A
8-3	Yes	Yes	3	3				I	N/A	N/A	N/A	N/A	N/A
8-98	Yes	Yes	3	3				I	N/A	N/A	N/A	N/A	N/A
10-2	Yes	Yes	2	2				I	10	20	30	40	50
10-5	Yes	Yes	5	5				I	10	20	30	40	50
10-6	Yes	Yes	6	6				I	10	20	30	40	50
10-20	Yes	Yes	2		2			I	10	20	30	40	50
12-3	Yes	Yes	3		3			I	10	20	30	40	50
12-12	Yes	Yes	12	12				I	10	20	30	40	50
14-4	Yes	Yes	4			4		I	10	20	30	40	50
14-7	Yes	Yes	7		7			I	10	20	30	40	50
14-12	Yes	Yes	12	9	3			I	10	20	30	40	50
14-15	Yes	Yes	15	15				I	10	20	30	40	50
16-10	Yes	Yes	10		10			I	10	20	30	40	50
16-24	Yes	Yes	24	24				I	10	20	30	40	50
18-8	Yes	Yes	8			8		I	10	20	30	40	50
18-14	Yes	Yes	14		14			I	10	20	30	40	50
18-31	Yes	Yes	31	31				I	10	20	30	40	50
20-16	Yes	Yes	16		16			I	10	20	30	40	50
20-25	Yes	Yes	25	19		6		I	10	20	30	40	50
20-28	Yes	Yes	28	24		4		I	10	20	30	40	50
20-39	Yes	Yes	39	37	2			I	10	20	30	40	50
20-41	Yes	Yes	41	41				I	10	20	30	40	50
22-12	Yes	Yes	12			12		I	10	20	30	40	50
22-19	Yes	Yes	19		19			I	10	20	30	40	50
22-32	Yes	Yes	32	26		6		I	10	20	30	40	50
22-55	Yes	Yes	55	55				I	10	20	30	40	50
24-19	Yes	Yes	19			19		I	10	20	30	40	50
24-29*	N/A	Yes	29		29			I	10	20	30	40	50
24-30*	N/A	Yes	30		30			I	10	20	30	40	50
24-43	Yes	Yes	43	23	20			I	10	20	30	40	50
24-57	Yes	Yes	57	55		2		I	10	20	30	40	50
24-61	Yes	Yes	61	61				I	10	20	30	40	50
28-42*	N/A	Yes	42		42			I	10	20	30	40	50

\* Non MIL-STD-1554 layout, available to Aero-Electric part number only.  
 Δ Consult factory for pin insert availability.

\*\* Alternate clocking positions (1, 2, 3, 4, and 5) are for interchangeability use only. Inactive for new design per MIL-STD-1554.



**Insert Arrangement Views**

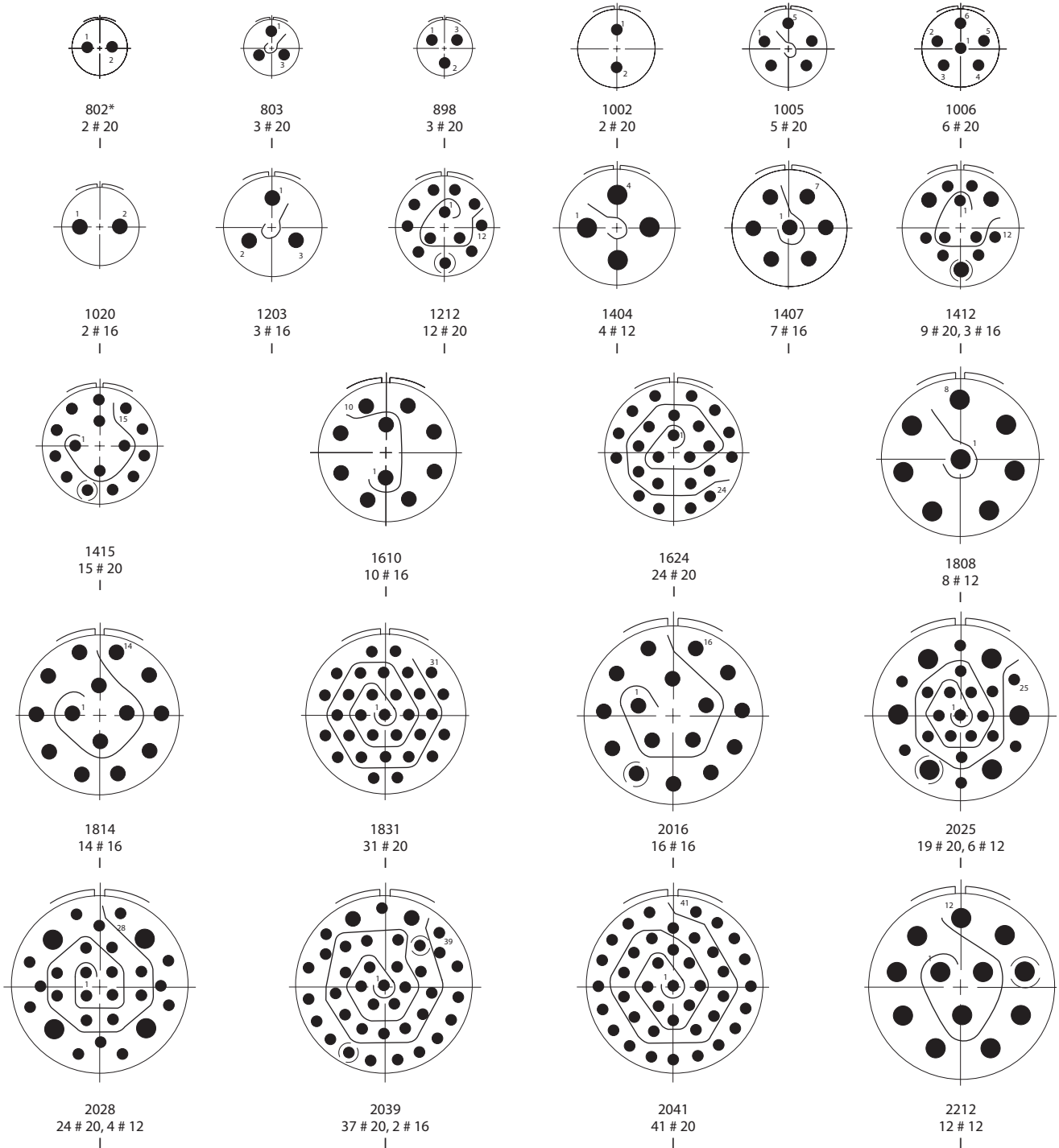

\* Consult factory for pin insert availability.

**83723 S III**



**MIL-STD-1554**

**Insert Arrangements (Socket Front View)  
for MIL-DTL-83723 Series III Connectors**



**Insert Arrangement Views**

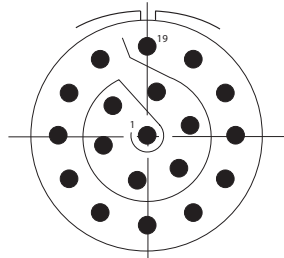

2219  
19 # 16

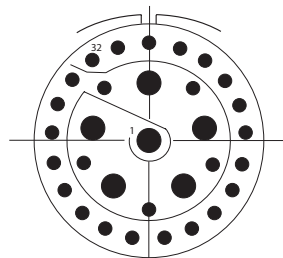

2232  
26 # 20, 6 # 12

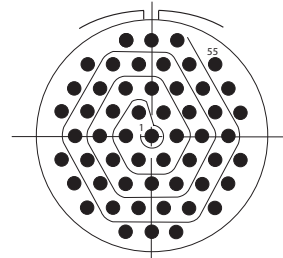

2255  
55 # 20

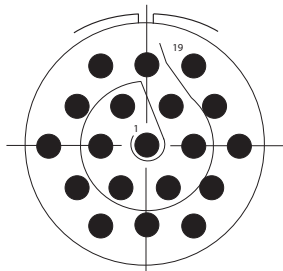

2419  
19 # 12

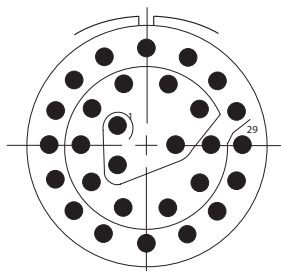

2429Δ  
29 # 16

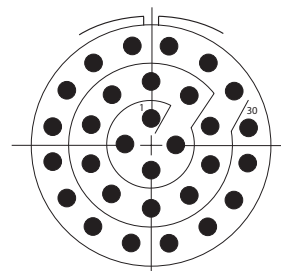

2430Δ  
30 # 16

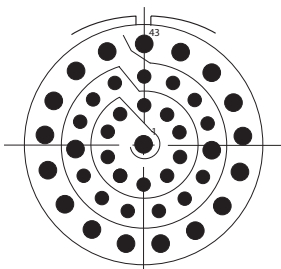

2443  
23 # 20, 20 # 16

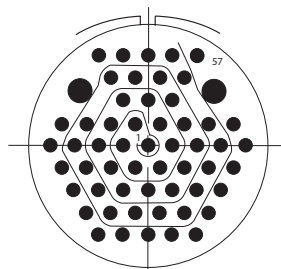

2457  
55 # 20, 2 # 12

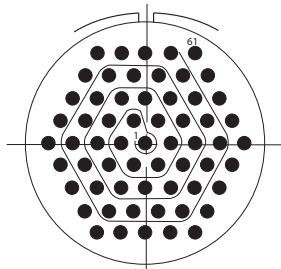

2461  
61 # 20

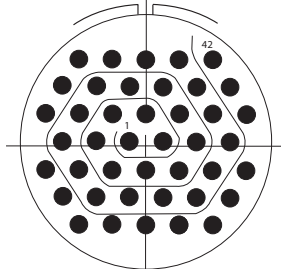

2842Δ  
42 # 16

83723 S III

Δ Non MIL-STD-1554 layout, available to Aero-Electric part number only.

## Features and Application

MIL-DTL-26500 family offers connectors with bayonet coupling as well as threaded coupling. These connectors are intermateable with correspondingly coupled MIL-DTL-83723 Series III connectors (except shell size 8, threaded coupling only).

AE66 connectors are widely used on commercial, military and aerospace systems requiring general-purpose, miniature cylindrical bayonet or threaded coupling connectors.

This family (bayonet as well as threaded) of connectors is offered in wall mount receptacles, jam nut mounted receptacles which incorporate O’ring seals, designed for rear panel “D” hole mounting, and straight plugs.

Twenty-one insert arrangements per MIL-STD-1554 are tooled and qualified to MIL-DTL-26500, utilizing 3 to 57 M39029 contacts. Contacts come in sizes 20, 16 and 12, terminating wire sizes from 24 to 12 gauge.

These connectors are only available in aluminum shells with anodic plating to the MS number. In addition, we offer connectors with passivated stainless steel shells to commercial callouts only.

### Insert Polarization

Alternate insert positions documented in the original specification, positions 1 through 5, are still available (except in shell size 8), but are not approved for new design. These alternate insert clocking positions aid in mating of adjacent connectors having identical insert arrangement.

**Shell Polarization** – Alternate key/keyway positions prevent cross mating of adjacent connectors having same insert arrangement.

**Connector Sealing** – A pressure seal at the connector interface is accomplished through the aid of a coupling device which compresses the front resilient insulators and thus offers a seal around each contact preventing the passage of moisture through the contact cavity. Rear resilient insulators are designed with a triple wire seal in each cavity to offer positive sealing and prevent wicking of moisture through the connector without the use of external clamping devices or adapters. In addition, a dynamic O’ring seal in the receptacles engages the front of the plug shell when connectors are mated and offers yet another barrier to moisture and contaminants.

**Superior Contact Stability** - Front release crimp contact system features a beryllium-copper retaining clip completely encased in a tough dielectric wafer, thus protecting the clip tines from damage.

### Closed Entry Socket Contacts

Closed-entry socket contacts facilitate positive mating.



**MIL-DTL-26500**  
**Performance Specifications**  
**MS2426\*/AE66\***



## Performance Specifications

### Operating Temperature Range

Class R: -55°C to +200°C (-67°F to +392°F)  
 Class E\*: -55°C to +200°C (-67°F to +392°F)

### Material and Finish Data (Class)

R – aluminum shell, black anodized finish  
 E\* – stainless steel shell, passivated

### Corrosion Resistance

Classes R and E\* withstand 48-hour salt spray.

### Environmental Seal

Wired, mated connectors shall meet the altitude-immersion test specified by MIL-DTL-26500.

### Fluid Resistance

Unmated connectors resist specified immersions in MIL-PRF-5606 (hydraulic fluid), MIL-PRF-23699 (lubricating oil), MIL-PRF-7808 (lubricating oil), MIL-DTL-5624 (JP-5) and glycol.

### Durability

Bayonet Coupling – 500 cycles  
 Threaded Coupling – 200 cycles

### Shock and Vibration Requirements

Wired, mated connectors shall not be damaged, coupling ring shall not loosen, and there shall be no interruption of electrical continuity longer than one microsecond when subjected to the following:

#### Shock

Mated connectors withstand a pulse of approximate half sine wave of 100 G magnitude with duration of 6 milliseconds applied in each of the three major axes.

#### Vibration

Mated connectors withstand the following vibration levels:

- Vibration per EIA-364, test procedure 28 conducted at a low temperature ambient of -55°C (-67°F) and high ambient of +200°C (392°F).

#### Shell-to-Shell Conductivity

- Class R is non-conductive.
- Maximum potential drop shall not exceed 200 millivolts for class E\*.

### Voltage Rating

Service Rating	Suggested Operating Voltage**		Test Voltage	Test Voltage	Test Voltage	Test Voltage
	(Sea Level)		Sea Level	50,000 Ft.	70,000 Ft.	110,000 Ft.
	AC (RMS)	DC	V RMS	V RMS	V RMS	V RMS
I	600	850	1500	450	275	200

\* Class E only available to commercial callouts. Consult factory for drawings. Pages 153 thru 158 apply to class R only.

\*\* To be used by designer only as a guide.



**MIL-DTL-26500**

**Part Number Development  
Bayonet & Threaded Coupling**

**Part Number Development**

<b>Mil. Prefix</b>	<b>MS</b>	<b>24266</b>	<b>R</b>	<b>12</b>	<b>T</b>	<b>12</b>	<b>P</b>	<b>N</b>	
<b>Aero Prefix</b>	<b>AE</b>	<b>666</b>	<b>R</b>	<b>12</b>	<b>T</b>	<b>12</b>	<b>P</b>	<b>N</b>	<b>-340</b>
<b>Shell type</b>									
24264 = Wall mount receptacle = <b>664</b> (Aero p/n)									
24265 = Jam nut receptacle = <b>665</b> (Aero p/n)									
24266 = Straight plug = <b>666</b> (Aero p/n)									
<b>Class (Material and Finish)</b>									
R = Aluminum shell, black anodized finish									
E* = Stainless steel shell, passivated									
<b>Shell Size (SS)</b>									
8, 10, 12, 14, 16, 18, 20, 22 or 24									
<b>Coupling Mechanism</b>									
B = Bayonet Coupling									
T = Threaded Coupling									
<b>Insert Arrangement</b>									
See pages 164									
<b>Contact Style</b>									
P = Pin									
S = Socket									
<b>Polarization (Keying)</b>									
N = Normal									
6, 7, 8, 9 or Y (Alternate keyed positions, Y is not available in SS 8)									
1, 2, 3, 4 or 5 (Locked insert polarizations within normally keyed shell, not approved for new design, n/a in SS 8)									
<b>Modification</b> (applies to Aero part numbers only)									
01 = Less contacts (is not marked on the part)									
341 = Connector kitted with MS27291-XX straight clamp									
Consult factory for other modifications									

\* Class E only available to commercial callouts. Consult factory for drawings. Pages 153 thru 158 apply to class R only.

**Note 1:** Each connector is furnished with contacts unless ordered less contacts (L/C) as follows: Two spare contacts for each size contact utilized and at least 15% of the number of contacts but no less than three sealing plugs are provided. No insertion/removal tools are provided. No spares are required for shielded contacts.

**Note 2:** Proper part number marking has no “0” in front of single digit shell size (8), and no “0” in front of single digit layouts. Example: MS24264R8B3SN and MS24264R18B8P6. Please note that in this series “N” for normal is included in part number marking.

**MS24264R\*\*B**  
**Wall Mounting Receptacle**  
**AE664R\*\*B**



**Bayonet Coupling, Crimp Removable, Front Release**

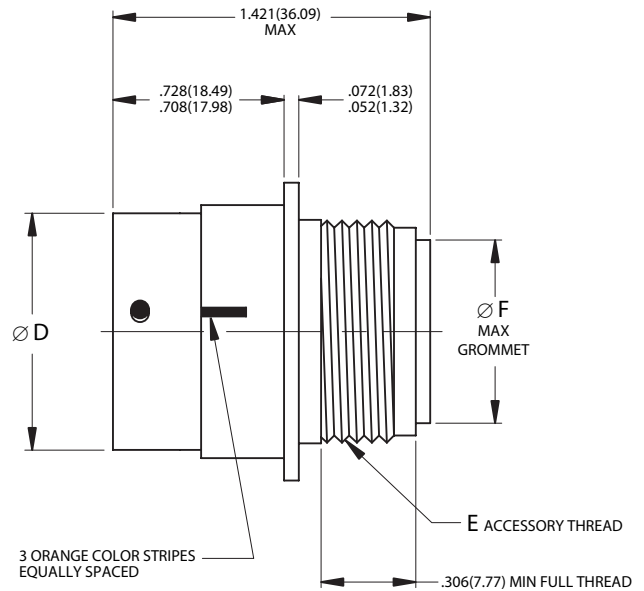
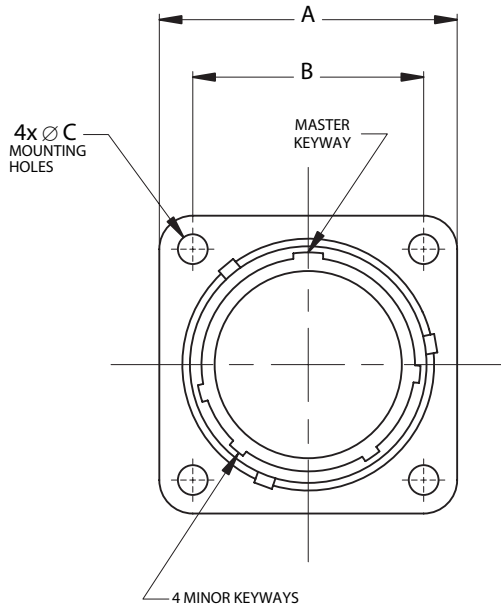

**PANEL THICKNESS:**  
 .125(3.18)MAX

Page 152	Completed Part Number
Page 161	Contacts, Sealing Plugs and Tools
Page 164	Insert Arrangements
Page 151	Performance Specifications
Page 163	Insert Availability and Contact Information
Page 160	Polarization

Shell Size	A		B		$\varnothing$ C		$\varnothing$ D		E	$\varnothing$ F	
	$\pm$ .005	$\pm$ .13	(TP)		+0.000	+0.00	+0.000	+0.00	Accessory Thread Class 2A	Maximum	
	inch	mm	inch	mm	inch	mm	inch	mm		inch	mm
8	.812	20.62	.594	15.09	.125	3.18	.536	13.61	7/16-28UNEF	.328	8.33
10	.937	23.80	.719	18.26	.125	3.18	.659	16.74	9/16-24UNEF	.420	10.67
12	1.031	26.19	.812	20.62	.125	3.18	.829	21.06	3/4-20UNEF	.580	14.73
14	1.125	28.58	.906	23.01	.125	3.18	.898	22.81	13/16-20UNEF	.664	16.87
16	1.250	31.75	.969	24.61	.125	3.18	1.025	26.04	15/16-20UNEF	.769	19.53
18	1.343	34.11	1.062	26.97	.125	3.18	1.131	28.73	1-1/16-18UNEF	.902	22.91
20	1.437	36.50	1.156	29.36	.125	3.18	1.256	31.90	1-3/16-18UNEF	1.033	26.24
22	1.562	39.67	1.250	31.75	.125	3.18	1.381	35.08	1-5/16-18UNEF	1.152	29.26
24	1.703	43.26	1.375	34.93	.154	3.91	1.506	38.25	1-7/16-18UNEF	1.282	32.56

26500

**Bayonet Coupling, Crimp Removable, Front Release**

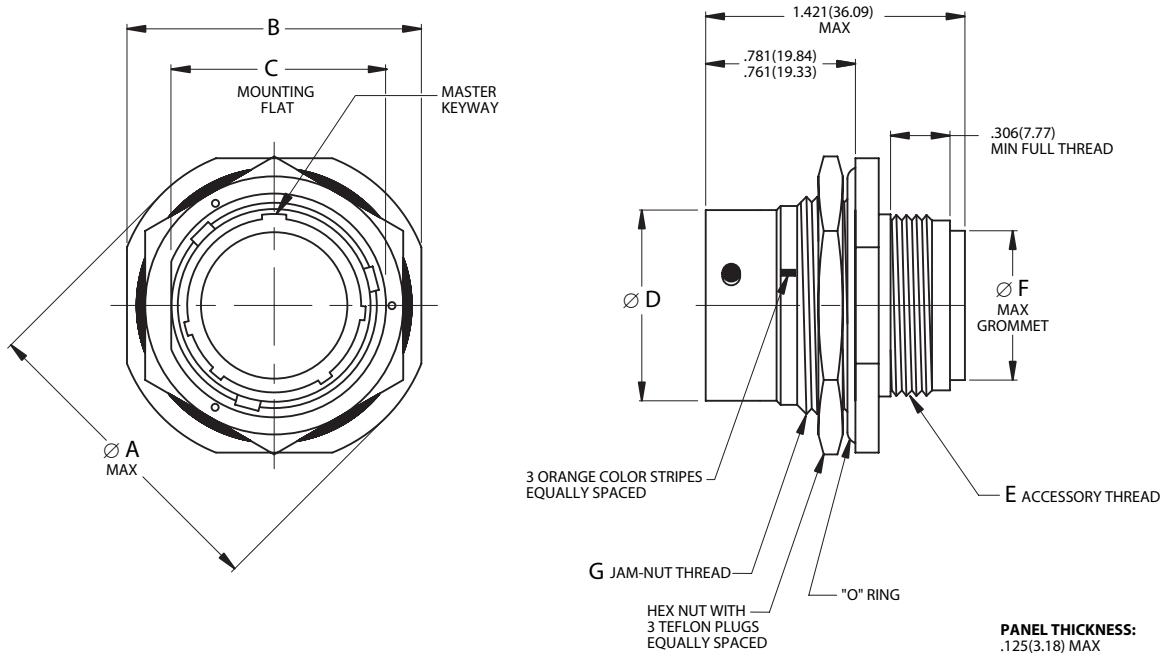

Page 152	Completed Part Number
Page 161	Contacts, Sealing Plugs and Tools
Page 164	Insert Arrangements
Page 151	Performance Specifications
Page 163	Insert Availability and Contact Information
Page 160	Polarization

Shell Size	Ø A		B		C		Ø D		E	Ø F		G
	Maximum		±.005	±.13	±.003	±.08	+0.000	+0.00	Accessory Thread Class 2A	Maximum		Jam Nut Thread Class 2A
	inch	mm	inch	mm	inch	mm	inch	mm		inch	mm	
8	1.068	27.13	.979	24.87	.593	15.06	.536	13.61	7/16-28UNEF	.328	8.33	5/8-20UN
10	1.192	30.28	1.104	28.04	.718	18.24	.659	16.74	9/16-24UNEF	.420	10.67	3/4-20UNEF
12	1.380	35.05	1.291	32.79	.905	22.99	.829	21.06	3/4-20UNEF	.580	14.73	15/16-20UNEF
14	1.505	38.23	1.391	35.33	.968	24.59	.898	22.81	13/16-20UNEF	.664	16.87	1-20UNEF
16	1.630	41.40	1.516	38.51	1.093	27.76	1.025	26.04	15/16-20UNEF	.769	19.53	1-1/8-20UN
18	1.740	44.20	1.641	41.68	1.217	30.91	1.131	28.73	1-1/16-18UNEF	.902	22.91	1-1/4-20UN
20	1.860	47.24	1.766	44.86	1.342	34.09	1.256	31.90	1-3/16-18UNEF	1.033	26.24	1-3/8-18UNEF
22	2.040	51.82	1.954	49.63	1.467	37.26	1.381	35.08	1-5/16-18UNEF	1.152	29.26	1-1/2-20UN
24	2.160	54.86	2.079	52.81	1.592	40.44	1.506	38.25	1-7/16-18UNEF	1.282	32.56	1-5/8-18UNEF

**MS24266R\*\*B**  
**Straight Plug**  
**AE666R\*\*B**



**Bayonet Coupling, Crimp Removable, Front Release**

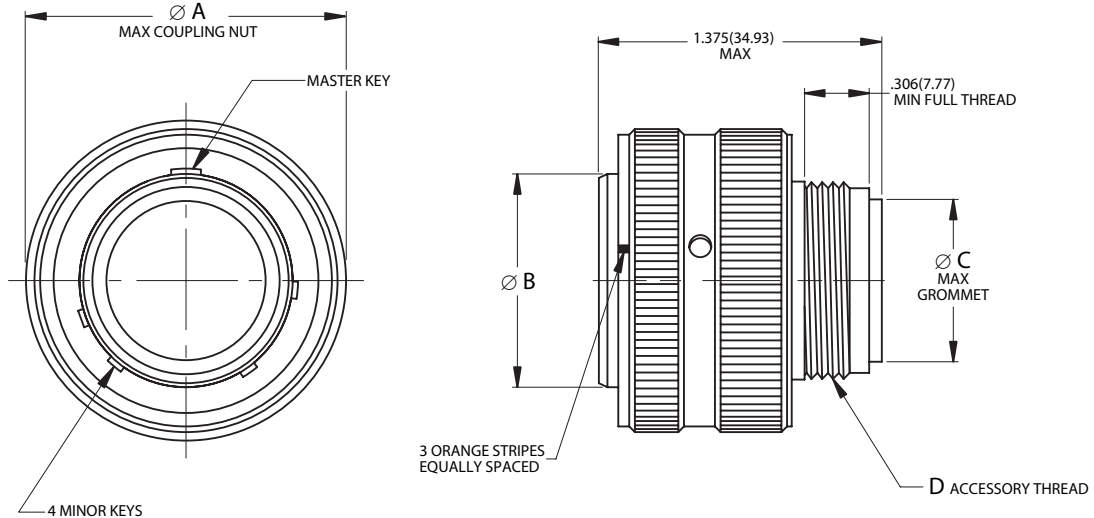

Page 152	Completed Part Number
Page 161	Contacts, Sealing Plugs and Tools
Page 164	Insert Arrangements
Page 151	Performance Specifications
Page 163	Insert Availability and Contact Information
Page 160	Polarization

Shell Size	$\varnothing A$		$\varnothing B$		$\varnothing C$		<b>D</b>
	Maximum		+0.00	<b>+0.00</b>	Maximum		Accessory Thread Class 2A
	inch	<b>mm</b>	-0.005	<b>-0.13</b>	inch	<b>mm</b>	
8	.776	<b>19.71</b>	.424	<b>10.77</b>	.328	<b>8.33</b>	7/16-28UNEF
10	.906	<b>23.01</b>	.526	<b>13.36</b>	.420	<b>10.67</b>	9/16-24UNEF
12	1.078	<b>27.38</b>	.696	<b>17.68</b>	.580	<b>14.73</b>	3/4-20UNEF
14	1.141	<b>28.98</b>	.765	<b>19.43</b>	.664	<b>16.87</b>	13/16-20UNEF
16	1.266	<b>32.16</b>	.892	<b>22.66</b>	.769	<b>19.53</b>	15/16-20UNEF
18	1.375	<b>34.93</b>	.998	<b>25.35</b>	.902	<b>22.91</b>	1-1/16-18UNEF
20	1.510	<b>38.35</b>	1.123	<b>28.52</b>	1.033	<b>26.24</b>	1-3/16-18UNEF
22	1.625	<b>41.28</b>	1.248	<b>31.70</b>	1.152	<b>29.26</b>	1-5/16-18UNEF
24	1.760	<b>44.70</b>	1.373	<b>34.87</b>	1.282	<b>32.56</b>	1-7/16-18UNEF

26500



**Threaded Coupling, Crimp Removable, Front Release**

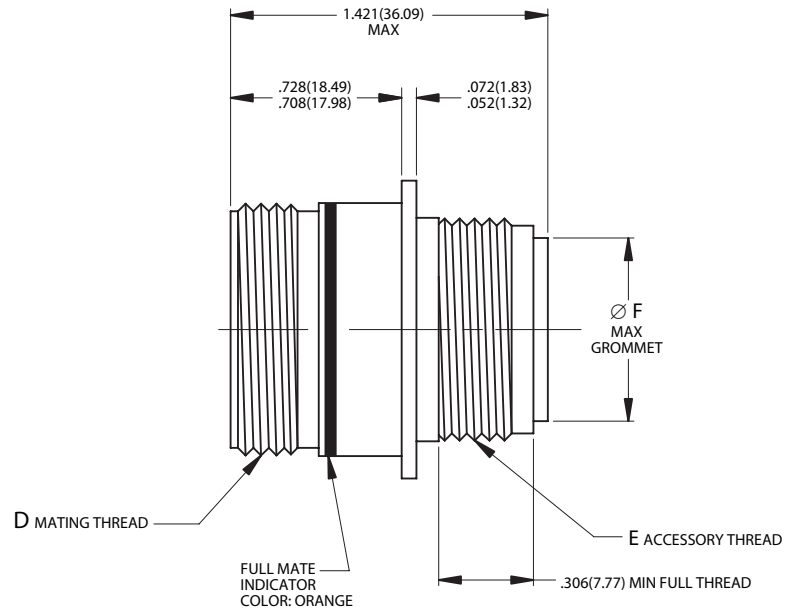
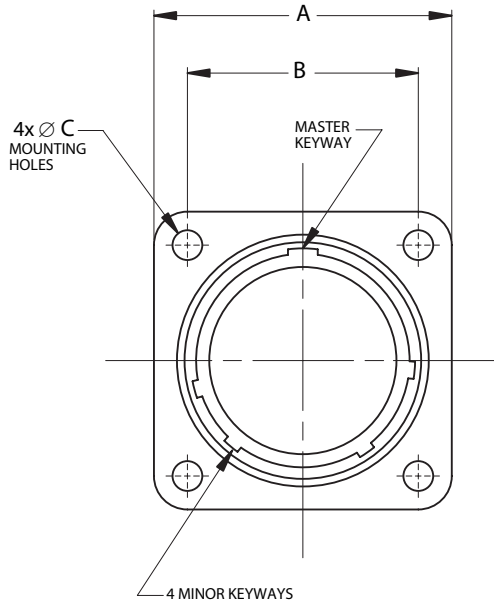

**PANEL THICKNESS:**  
.125(3.18) MAX

Page 152	Completed Part Number
Page 161	Contacts, Sealing Plugs and Tools
Page 164	Insert Arrangements
Page 151	Performance Specifications
Page 163	Insert Availability and Contact Information
Page 160	Polarization

Shell Size	A		B		$\varnothing$ C		D	E	$\varnothing$ F	
	$\pm$ .005	$\pm$ .13	(TP)		+.000	+.00	Mating Thread	Accessory Thread	Maximum	
	inch	mm	inch	mm	inch	mm	Class 2A	Class 2A	inch	mm
8	.812	20.62	.594	15.09	.125	3.18	9/16-24UNEF	7/16-28UNEF	.328	8.33
10	.937	23.80	.719	18.26	.125	3.18	11/16-24UNEF	9/16-24UNEF	.420	10.67
12	1.031	26.19	.812	20.62	.125	3.18	7/8-20UNEF	3/4-20UNEF	.580	14.73
14	1.125	28.58	.906	23.01	.125	3.18	15/16-20UNEF	13/16-20UNEF	.664	16.87
16	1.250	31.75	.969	24.61	.125	3.18	1-1/16-18UNEF	15/16-20UNEF	.769	19.53
18	1.343	34.11	1.062	26.97	.125	3.18	1-3/16-18UNEF	1-1/16-18UNEF	.902	22.91
20	1.437	36.50	1.156	29.36	.125	3.18	1-5/16-18UNEF	1-3/16-18UNEF	1.033	26.24
22	1.562	39.67	1.250	31.75	.125	3.18	1-7/16-18UNEF	1-5/16-18UNEF	1.152	29.26
24	1.703	43.26	1.375	34.93	.154	3.91	1-9/16-18UNEF	1-7/16-18UNEF	1.282	32.56



**MS24265R\*\*T**  
**Jam Nut Receptacle**  
**AE665R\*\*T**



**Threaded Coupling, Crimp Removable, Front Release**

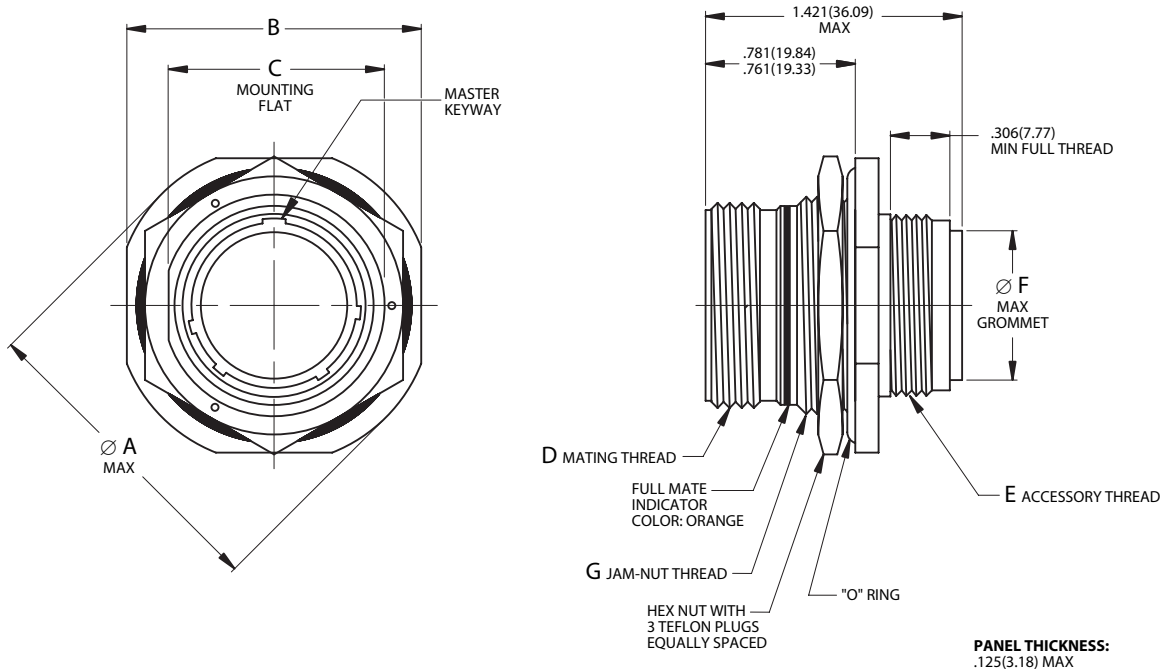

Page 152	Completed Part Number
Page 161	Contacts, Sealing Plugs and Tools
Page 164	Insert Arrangements
Page 151	Performance Specifications
Page 163	Insert Availability and Contact Information
Page 160	Polarization

Shell Size	Ø A		B		C		D	E	Ø F		G
	Maximum		±.005	±.13	±.003	±.08	Mating Thread Class 2A	Accessory Thread Class 2A	Maximum		Jam Nut Thread Class 2A
	inch	mm	inch	mm	inch	mm			inch	mm	
8	1.068	27.13	.979	24.87	.593	15.06	9/16-24UNEF	7/16-28UNEF	.328	8.33	5/8-20UN
10	1.192	30.28	1.104	28.04	.718	18.24	11/16-24UNEF	9/16-24UNEF	.420	10.67	3/4-20UNEF
12	1.380	35.05	1.291	32.79	.905	22.99	7/8-20UNEF	3/4-20UNEF	.580	14.73	15/16-20UNEF
14	1.505	38.23	1.391	35.33	.968	24.59	15/16-20UNEF	13/16-20UNEF	.664	16.87	1-20UNEF
16	1.630	41.40	1.516	38.51	1.093	27.76	1-1/16-18UNEF	15/16-20UNEF	.769	19.53	1-1/8-20UN
18	1.740	44.20	1.641	41.68	1.217	30.91	1-3/16-18UNEF	1-1/16-18UNEF	.902	22.91	1-1/4-20UN
20	1.860	47.24	1.766	44.86	1.342	34.09	1-5/16-18UNEF	1-3/16-18UNEF	1.033	26.24	1-3/8-18UNEF
22	2.040	51.82	1.954	49.63	1.467	37.26	1-7/16-18UNEF	1-5/16-18UNEF	1.152	29.26	1-1/2-20UN
24	2.160	54.86	2.079	52.81	1.592	40.44	1-9/16-18UNEF	1-7/16-18UNEF	1.282	32.56	1-5/8-18UNEF

26500

**Threaded Coupling, Crimp Removable, Front Release**

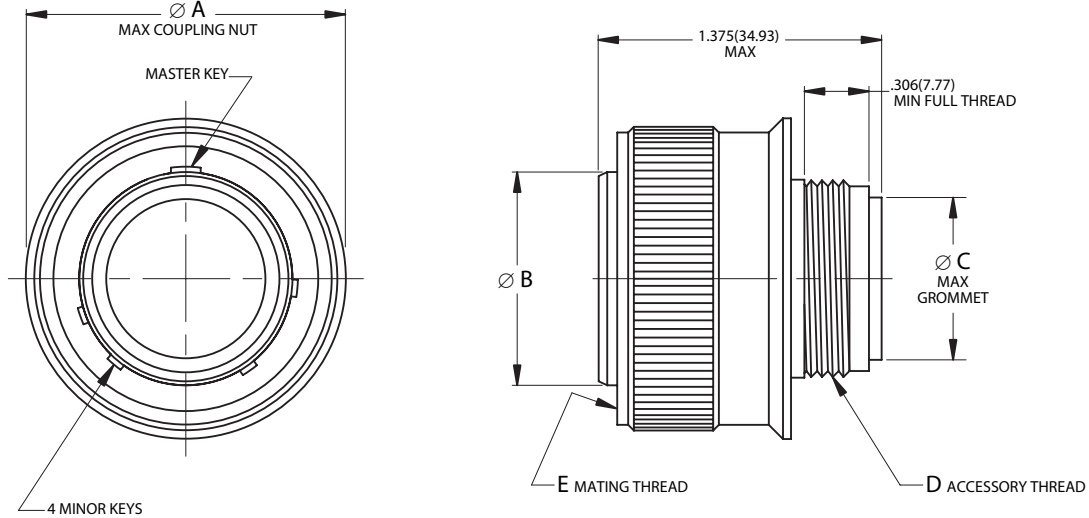

Page 152	Completed Part Number
Page 161	Contacts, Sealing Plugs and Tools
Page 164	Insert Arrangements
Page 151	Performance Specifications
Page 163	Insert Availability and Contact Information
Page 160	Polarization

Shell Size	$\varnothing A$		$\varnothing B$		$\varnothing C$		D	E
	Maximum		+0.00 -0.005	<b>+0.00</b> <b>-0.13</b>	Maximum		Accessory Thread Class 2A	Mating Thread Class 2B
	inch	mm	inch	mm	inch	mm		
8	.776	<b>19.71</b>	.424	<b>10.77</b>	.328	<b>8.33</b>	7/16-28UNEF	9/16-24UNEF
10	.906	<b>23.01</b>	.526	<b>13.36</b>	.420	<b>10.67</b>	9/16-24UNEF	11/16-24UNEF
12	1.078	<b>27.38</b>	.696	<b>17.68</b>	.580	<b>14.73</b>	3/4-20UNEF	7/8-20UNEF
14	1.141	<b>28.98</b>	.765	<b>19.43</b>	.664	<b>16.87</b>	13/16-20UNEF	15/16-20UNEF
16	1.266	<b>32.16</b>	.892	<b>22.66</b>	.769	<b>19.53</b>	15/16-20UNEF	1-1/16-18UNEF
18	1.375	<b>34.93</b>	.998	<b>25.35</b>	.902	<b>22.91</b>	1-1/16-18UNEF	1-3/16-18UNEF
20	1.510	<b>38.35</b>	1.123	<b>28.52</b>	1.033	<b>26.24</b>	1-3/16-18UNEF	1-5/16-18UNEF
22	1.625	<b>41.28</b>	1.248	<b>31.70</b>	1.152	<b>29.26</b>	1-5/16-18UNEF	1-7/16-18UNEF
24	1.760	<b>44.70</b>	1.373	<b>34.87</b>	1.282	<b>32.56</b>	1-7/16-18UNEF	1-9/16-18UNEF

26500

Shell Keying

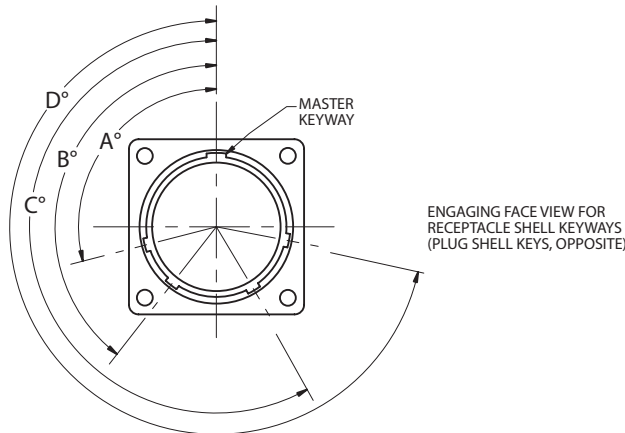

Insert Clocking

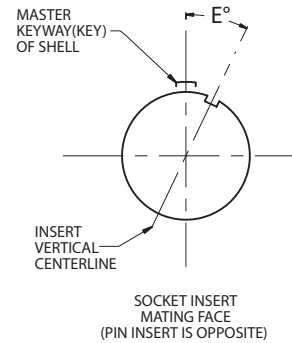

Notes:

1. In the normal position (N), the insert centerline coincides with the centerline of the master keyway (key) of the shell:  $E = 0^\circ$ .
2. In the alternate keying positions (6, 7, 8, 9 and Y), the minor keyways (keys) are positioned with reference to master key/keyway as indicated in the keying position table below.
3. In the alternate insert clocking positions (1, 2, 3, 4 and 5), the socket insert (viewing from the mating side) is rotated counter-clockwise relative to the centerline of the master keyway (key) of the shell. The pin insert is rotated clockwise.

Shell Size	Polarizing	Key/Keyway Positions				Insert Position
	Position	A°	B°	C°	D°	E°
8*, 10	N	105	140	215	265	0
	6	102	132	248	320	0
	7	80	118	230	312	0
	8	35	140	205	275	0
	9	64	155	234	304	0
10 only	Y**	25	115	220	270	0
12 thru 24	N	105	140	215	265	0
	6	18	149	192	259	0
	7	92	152	222	342	0
	8	84	152	204	334	0
	9	24	135	199	240	0
	Y**	98	152	268	338	0
10 thru 24	1†	105	140	215	265	10
	2†	105	140	215	265	20
	3†	105	140	215	265	30
	4†	105	140	215	265	40
	5†	105	140	215	265	50

\* Per MIL-STD-1554, keyed position Y and clocked positions 1, 2, 3, 4 and 5 are not available in shell size 8.

† Per MIL-STD-1554, insert positions 1 thru 5 are inactive for new design.

\*\* Alternate positions "Z" and "10" are cancelled and superseded by Position "Y".

**Panel Cutouts**

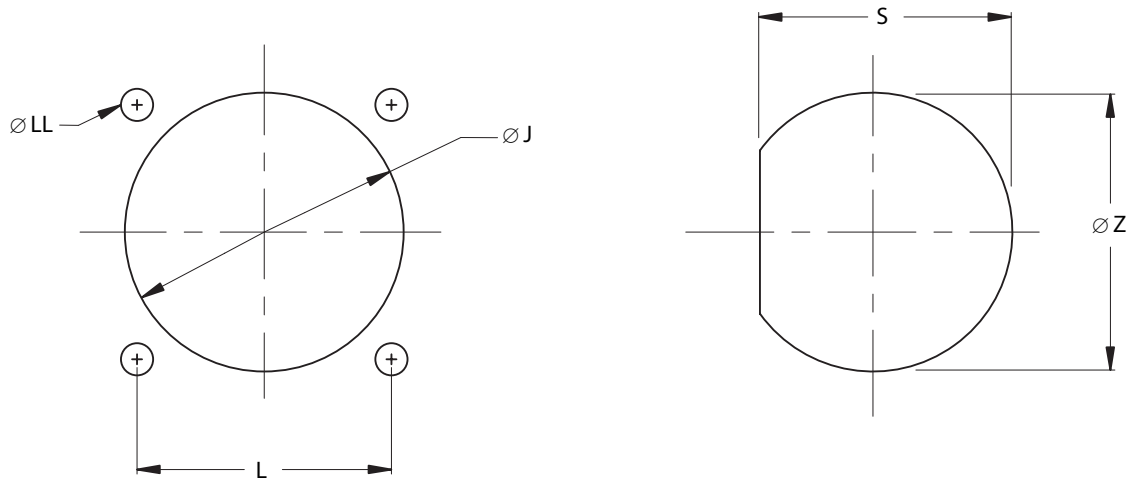

**Note:** Maximum panel thickness of .125 inch (3.18 mm).

**Flange and Jam Nut Mounting Dimensions**

Shell Size	L		Ø J		Ø J		Ø LL		S		Ø Z	
	(TP)		For Back Mounting Minimum		For Front Mounting Minimum		+0.000	+0.00	±.005		±.13	
	inch	mm	inch	mm	inch	mm	inch	mm	inch	mm	inch	mm
8	.594	15.09	.620	15.75	.447	11.35	.125	3.18	.605	15.37	.635	16.13
10	.719	18.26	.748	19.00	.572	14.53	.125	3.18	.730	18.54	.760	19.30
12	.812	20.62	.913	23.19	.760	19.30	.125	3.18	.917	23.29	.947	24.05
14	.906	23.01	.980	24.89	.822	20.88	.125	3.18	.980	24.89	1.010	25.65
16	.969	24.61	1.107	28.12	.948	24.08	.125	3.18	1.105	28.07	1.135	28.83
18	1.062	26.97	1.209	30.71	1.072	27.23	.125	3.18	1.225	31.12	1.260	32.00
20	1.156	29.36	1.337	33.96	1.192	30.28	.125	3.18	1.350	34.29	1.385	35.18
22	1.250	31.75	1.452	36.88	1.322	33.58	.125	3.18	1.475	37.47	1.510	38.35
24	1.375	34.93	1.577	40.06	1.442	36.63	.154	3.91	1.600	40.64	1.635	41.53

**MIL-DTL-26500**  
**Contacts, Tools and Seal Plugs**  
**MS2426\*/AE66\***



**Contacts, Plastic Insertion/Removal Tools and Seal Plugs**

Contact Size	Application	Pin Contacts	Socket Contacts	Seal Plugs	Insertion/Removal Tools
	Type	Military No.	Military No.	Military No.	Military No.
					Plastic
20	Power/Signal	M39029/31-241	M39029/32-260	MS27488-20-1	N/A
16	Power/Signal	M39029/31-229	M39029/32-248	MS27488-16-1	N/A
12	Power/Signal	M39029/31-235	M39029/32-254	MS27488-12-1	N/A
8 Coax	Coax	M39029/54-343	M39029/55-345	MS27488-8-1	N/A

**Crimping and Metal Insertion/Extraction Tools**

Contact Size/Type	Crimp Tool	Positioner	Positioner	Insertion Tool	Extraction Tool
		For Pin Contacts	For Socket Contacts	Metal	Metal
	Military No.	Military No.	Military No.	Military No.	Military No.
20	M22520/1-01	M22520/1-02	M22520/1-02	M81969/17-03	M81969/19-07
	M22520/2-01	M22520/2-02	M22520/2-02		
16	M22520/1-01	M22520/1-02	M22520/1-02	M81969/17-04	M81969/19-08
12	M22520/1-01	M22520/1-02	M22520/1-02	M81969/17-05	M81969/19-09
8 Coax Inner	M22520/2-01	M22520/2-24	M22520/2-24	M81969/17-06	M81969/19-03
8 Coax Outer	M22520/5-01	M22520/5-10	M22520/5-10		

**Contact and Wire Data**

Contact Size	Test Current	Potential	Crimp Well Data			Wire Range		Finished Wire Ø Range			
	DC Test	Drop	Well Dia.	Minimum Well Dept		AWG	mm <sup>2</sup>	Minimum		Maximum	
	Amps	Millivolts	inch	inch	mm			inch	mm	inch	mm
20	7.5	55	.049 ±.001	.267	6.78	24-20	.20-.52	.040	1.02	.090	2.29
16	13.0	49	.067 ±.001	.236	5.99	20-16	.52-1.31	.068	1.73	.130	3.30
12	23.0	42	.100 ±.002	.236	5.99	14-12	2.08-3.31	.106	2.69	.170	4.32

**Note 1:** Test Current and Maximum Voltage Drop when tested with silver-plated wire at 25°C.

**Note 2:** No plastic Insertion/Removal tools are supplied as part of contact packages when ordering 26500 connectors. Metal insertion and extraction tools must be ordered separately.



**MIL-DTL-26500**  
**Contact Installation Instructions**  
**MS2426\*/AE66\***

## Contact Installation Instructions

### Crimping Contacts

1. Select the appropriate crimp tool and ensure that the proper crimp head positioner is used.
2. Cycle the tool to be sure the indentors are open.
3. Determine the correct selector setting for the wire size from the data plate on the positioner (turret head assembly) and set the selector knob on the crimp tool to match.
4. Place the contact, mating end first, into the tool.
5. Insert the stripped wire into the hollow end of the contact. Be sure the wire is inserted as far as it will go.
6. Close the tool completely to crimp. Unless the tool is closed completely, the tool will not release the contact.
7. Remove the crimped contact from the tool. Check the inspection hole to verify that the wire is fully inserted.

### Insertion of Contacts

1. Before inserting the contacts, unscrew the accessories (clamps, backshells or adapters) from rear of plug or receptacle. Slide the hardware over the wire bundle in the proper order for reassembly after all the contacts are inserted.
2. To assist insertion of contacts, lubricate insulator (grommet) cavities with isopropyl alcohol. Alcohol will evaporate and will not leave a conductive film. **Caution: Never use any lubricant other than isopropyl alcohol.**
3. Place the correct insertion tool on the contact so that the wire runs along the groove in the tool. (Tool tip will butt against the shoulder.) Hold the plug or receptacle body firmly.

4. Beginning with a center cavity, insert the contact into the insulator with a slow, even pressure until the contact snaps into position. Make sure the contact and tool are held perpendicular to the face of the insert during the contact installation or the grommet could be damaged.
- 4.1 If contacts are not inserted all the way prior to removing insertion tool, do not try to reinsert the insertion tool. Instead, remove the contact and try again; otherwise reinserting the insertion tool may damage the inside of the contact cavity.
5. Remove tool and check the face of the connector for proper contact installation. Proper installation may also be checked by pulling back lightly on the wire to make sure the contact is properly seated.

### Completion

After all the cavities have been filled, slide the hardware back into position on the connector and tighten.

### Extraction of Contacts (Rework)

1. Slide the hardware back over the wire bundle.
2. Select the appropriate tool. Place tool over the contact on mating side and insert into the cavity.
3. Exert nominal force axially to release retention clip. Spacer sleeve will shoulder at face of insulation when tool is inserted to proper depth.
4. Push extraction plunger to force the contact out of the rear of the insert.
5. Grasp contact or wire and pull the wired contact out of the rear of the insulator.
6. Remove extraction tool axially.
7. After using the extraction tool, the spacer sleeve should be set forward in the last notch to protect the end of the plunger guide.

Size	Pin Contact	Socket Contact	Basic Crimp Tool	Positioner	Insertion Tool	Removal Tool
20	M39029/31-241	M39029/32-260	M22520/1-01	M22520/1-02 Red	M81969/17-03	M81969/19-07
			M22520/2-01	M22520/2-02		
16	M39029/31-229	M39029/32-248	M22520/1-01	M22520/1-02 Blue	M81969/17-04	M81969/19-08
12	M39029/31-235	M39029/32-254	M22520/1-01	M22520/1-02 Yellow	M81969/17-05	M81969/19-09

# MIL-DTL-26500 Bayonet and Threaded Insert Availability and Contact Information per MIL-STD-1554



## Insert Availability and Contact Information

Insert Arrangement	Aero-Electric		Total	Quantity of Contacts				Service	Alternate Positions				
	Status		No. of	(by Size)					(Insert Rotation in Degrees)				
	QPL'd	Tooled	Contacts	20	16	12	# 8 Coax	Rating	1*	2*	3*	4*	5*
8-3	Yes	Yes	3	3				I	N/A	N/A	N/A	N/A	N/A
10-5	Yes	Yes	5	5				I	10	20	30	40	50
12-3	Yes	Yes	3		3			I	10	20	30	40	50
12-12	Yes	Yes	12	12				I	10	20	30	40	50
14-4	Yes	Yes	4			4		I	10	20	30	40	50
14-7	Yes	Yes	7		7			I	10	20	30	40	50
14-12	Yes	Yes	12	9	3			I	10	20	30	40	50
14-15	Yes	Yes	15	15				I	10	20	30	40	50
16-10	Yes	Yes	10		10			I	10	20	30	40	50
16-24	Yes	Yes	24	24				I	10	20	30	40	50
18-8	Yes	Yes	8			8		I	10	20	30	40	50
18-11+	Yes	Yes	11		10		1	I	10	20	30	40	50
18-14	Yes	Yes	14		14			I	10	20	30	40	50
18-31	Yes	Yes	31	31				I	10	20	30	40	50
20-16	Yes	Yes	16		16			I	10	20	30	40	50
20-25	Yes	Yes	25	19		6		I	10	20	30	40	50
20-39	Yes	Yes	39	37	2			I	10	20	30	40	50
20-41	Yes	Yes	41	41				I	10	20	30	40	50
22-19	Yes	Yes	19		19			I	10	20	30	40	50
22-55	Yes	Yes	55	55				I	10	20	30	40	50
24-30**	N/A	Yes	30		30			I	10	20	30	40	50
24-43	Yes	Yes	43	23	20			I	10	20	30	40	50
24-57	Yes	Yes	57	55		2		I	10	20	30	40	50

\* Per MIL-STD-1554, insert positions 1 thru 5 are inactive for new design.

\*\* Non MIL-STD-1554 layout, available to Aero-Electric part number only.

+ Only available less contacts (no known source for QPL Coax contact)

Insert Arrangement Views

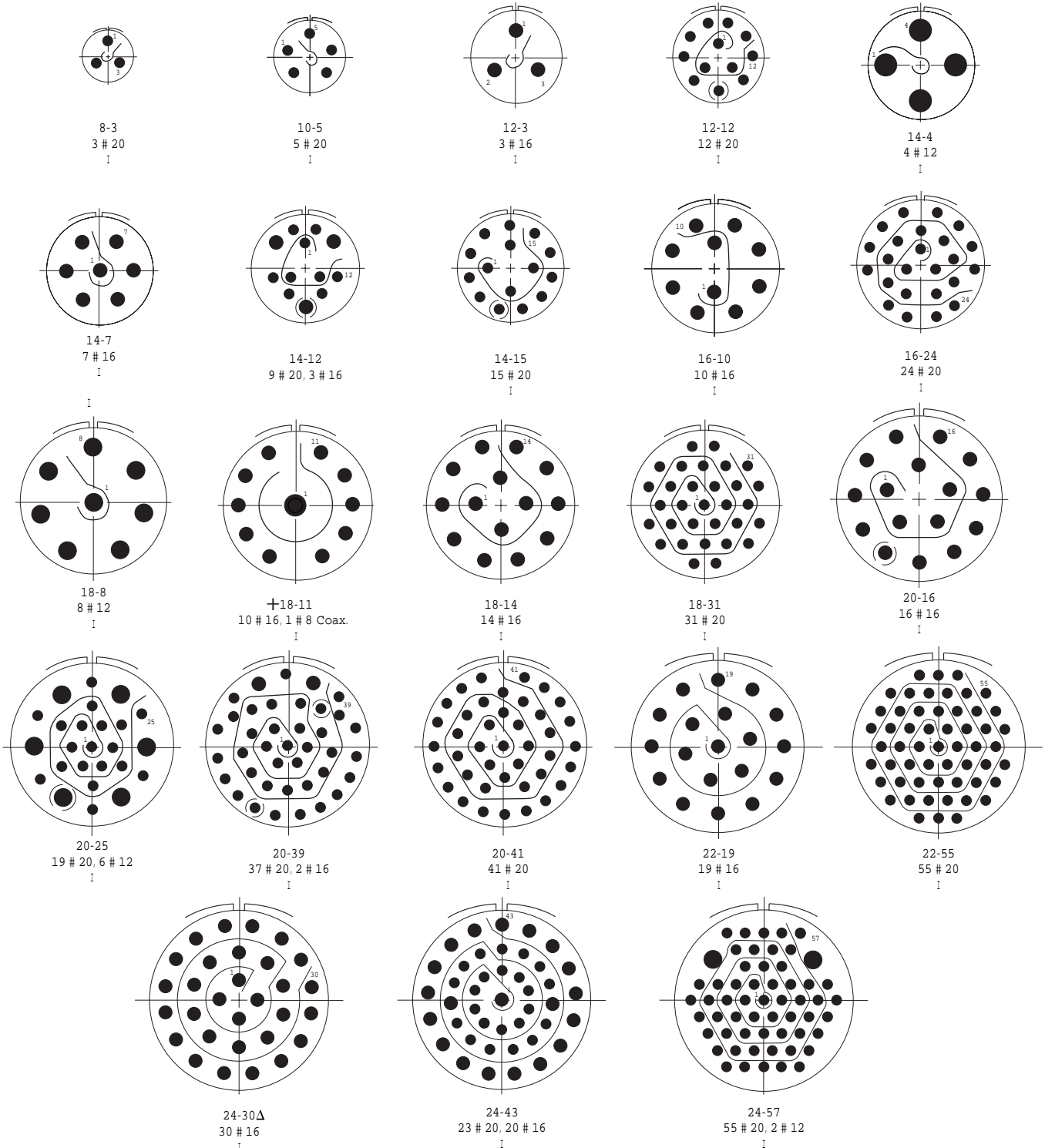

Δ Non MIL-STD-1554 layout, available to Aero-Electric part number only. + Only available less contacts (no known source for QPL Coax contact)



## Introduction

For many years, Aero Electric has been making mil circular connectors, and for nearly just as long, we have been supplying them with pc tail contacts. From all the applications we have supported with our pc tail connectors, and all the engineers we have worked with, we have finally taken all that we have learned and created a full product offering.

This product line is made in accordance with MIL-DTL-38999 and MIL-DTL-26482. This family of connectors offers multiple receptacle shell styles, and is available in several materials, such as aluminum, stainless steel, and for extreme corrosion environments, aluminum nickel bronze. The plating options are extensive as well, and that includes electroless nickel, olive drab cadmium, bright cadmium, hard anodized, black nickel, Zinc nickel, and Teflon nickel.

## Features

1. Clinch nut options for more secure mounting to the panel
2. Stand-off with helicoils for best practice when supporting the pcb to the connector
3. Shell to PC board connection to allow for another ground path, if needed
4. Slots on the shells to allow for aqueous wash to run through and clean post wave soldering

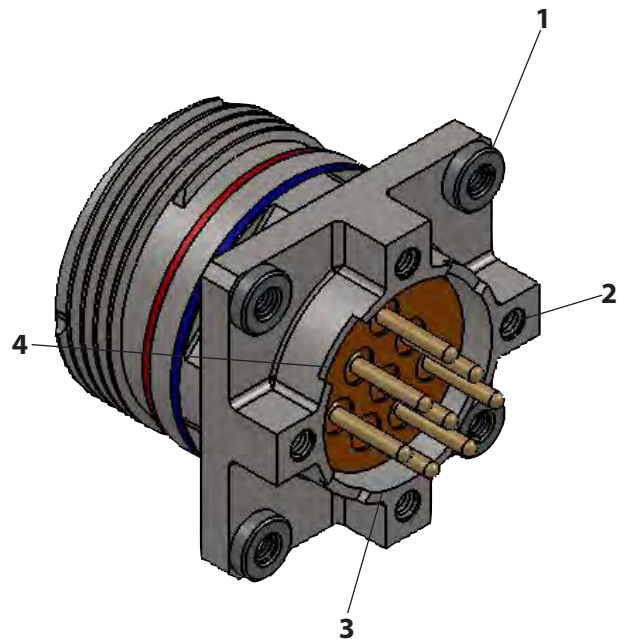

AEP65-104



## Table of Contents

AEP65-101, AEP65-102 .....	167-168
AEP65-103, AEP65-104 .....	169-170
AEP65-105, AEP65-106 .....	171-172
AE65-505 .....	173-174
AE65-255 .....	175-176
AE6520 .....	177-178
AE6524 .....	179-180
AEP45-101, AEP45-102 .....	181-182
AEP45-103, AEP45-104 .....	183-184
AEP45-105, AEP45-106 .....	185-186
AEP55-101, AEP55-102 .....	187-188
AEP55-103, AEP55-104 .....	189-190
AEP55-105, AEP55-106 .....	191-192
MIL-STD 1560 Insert Arrangement List .....	193
MIL-STD 1560 Insert Arrangement Views .....	194-208
AEP15-101, AEP15-102 .....	209-210
AEP15-103, AEP15-104 .....	211-212
AEP15-105, AEP15-106 .....	213-214
MIL-STD 1669 Insert Arrangement List .....	215
MIL-STD 1669 Insert Arrangement Views .....	216-228
PC Tail Lengths .....	229-234