

# Product Document



## Datasheet

SD000105

# AS585x

## 16-Bit 256-Channel Low Noise Charge-to-Digital Converters

v1-00 • 2020-Jun-19

---

---

# Content Guide

---

<b>1</b>	<b>General Description.....</b>	<b>3</b>	<b>4</b>	<b>Revision Information.....</b>	<b>8</b>
1.1	Key Benefits & Features .....	4	<b>5</b>	<b>Legal Information .....</b>	<b>9</b>
1.2	Applications .....	4			
1.3	Block Diagram .....	5			
<b>2</b>	<b>Ordering Information.....</b>	<b>6</b>			
<b>3</b>	<b>Tape &amp; Reel Information .....</b>	<b>7</b>			

---

# 1 General Description

---

The AS585x product family (AS5850, AS5851 and AS5852) is a 16 bit, 256-channel low-noise charge-to-digital converter designed for digital X-Ray systems. It enables a wide range of applications for digital X-Ray including static and dynamic Flat Panel Detectors (FPDs) used in radiographic imaging, digital mammography and high-speed fluoroscopy.

Each of the devices consists of 256 analog Charge Sensitive Amplifiers (CSA) with a programmable full-scale range, a Correlated Double Sampler (CDS) for offset compensation with programmable time constant and 128 multiplexed Analog-to-Digital Converters (ADC) for the digital readout of each pixel. The device can be configured for electrons and holes polarity and includes a voltage reference and a temperature sensor. Built-in diagnostic modes enable error detection in the signal chain.

The converted channels are output on a single LVDS interface with a data rate up to 320 Mbps for optimized line time. The serial SPI interface allows the configuration of the analog frontend including timing and different power modes for low stand-by power consumptions and fast startup times.

AS5850 is a high-speed design optimized for line times down to 20  $\mu\text{s}$  for dynamic flat panel detectors in fluoroscopy applications. In a special low-OSR (the ADC OverSampling Ratio) mode, it can reach even shorter line times of 15  $\mu\text{s}$ . Additionally, it is possible to bin together adjacent channels; with this binning, the fastest achievable line time is 10  $\mu\text{s}$ .

The AS5851 and AS5852 are low-power versions of AS5850 for static, portable and battery supplied flat panels with minimum power dissipations down to 1.1 mW per channel.

All devices are delivered per default on a Chip on Flex package to minimize sidewall distances and allow direct assembly on the X-Ray panel. The Flex design can be customized according to customer requirements. Alternatively, all devices can be delivered as dice on foil.

## 1.1 Key Benefits & Features

The benefits and features of AS585x, 16-Bit 256-Channel Low Noise Charge-to-Digital Converters, are listed below:

**Figure 1:**  
**Added Value of Using AS585x**

Benefits	Features
256 Channels with 16 bit resolution	Flexible and simple configuration via SPI interface supporting daisy-chaining multiple devices
Ultra-low noise down to 500 electrons at 2 pC input range for hole and electron integration	Standard and customized flex delivery down to 60µm pitch on the high-density side
Low power dissipation down to 1.1 mW per channel at 80 µs line time	Different power-down modes down to 1 µW per channel and fast start-up times
Line time down to 20 µs, 15 µs with low OSR or 10 µs with binning	LVDS data interface with data rate optimized readout modes including fully parallel pipeline mode
Adjustable full scale range from 0.5 pC to 16 pC	Correlated Double Sampling (CDS) operation for offset compensation with programmable time constant
On-chip voltage reference and temperature sensor	Built-in Diagnostic (anti-blooming circuit, charge injection mode, ADC test) for error detection

## 1.2 Applications

- X-Ray Flat Panel Detectors
- Digital Radiography
- Fluoroscopy Panels and Dynamic X-Ray Detectors
- Portable and Mobile X-Ray Systems
- Mammography Panels
- Industrial and Security X-Ray Scanner

### 1.3 Block Diagram

The functional blocks of the device are shown below:

**Figure 2 :**  
**Functional Blocks of AS585x**

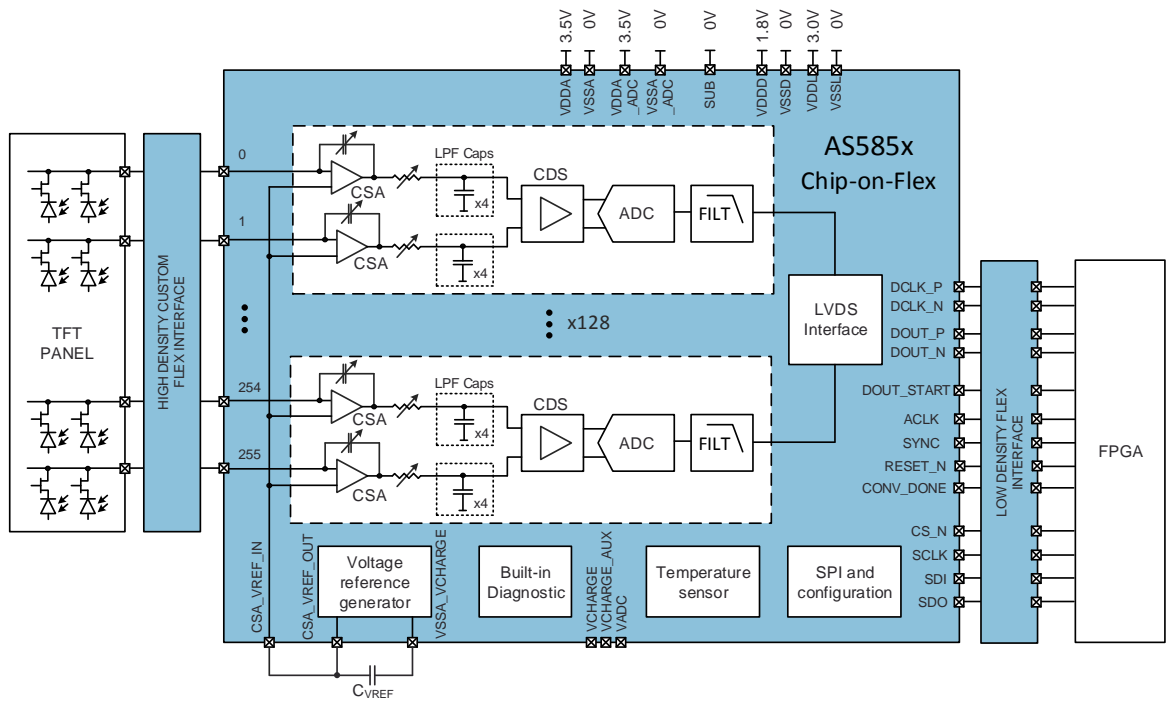

## 2 Ordering Information

Ordering Code	Package	Marking	Delivery Form	Delivery Quantity
AS5850-CSDF-240 <sup>(1)</sup>	Die, 240 Channels Device	AS5850-CSDF-240	Die on Foil	8 inch wafer
AS5850-CSDF-256 <sup>(1)</sup>	Die, 256 Channels Device	AS5850-CSDF-256	Die on Foil	8 inch wafer
AS5850A-CCFT-240 <sup>(1)</sup>	A-type Chip on Flex (COF), 240 Channels	AS5850A-CCFT-240	Reel	1500 flex/reel
AS5850A-CCFT-256	A-type Chip on Flex (COF), 256 Channels	AS5850A-CCFT-256	Reel	1500 flex/reel
AS5850B-CCFR-256	B-type Chip on Flex (COF), 256 Channels	AS5850B-CCFR-256	Tray	240 flex/package
AS5851B-CCFR-256	B-type Chip on Flex (COF), 256 Channels	AS5851B-CCFR-256	Tray	240 flex/package
AS5852B-CCFR-256	B-type Chip on Flex (COF), 256 Channels	AS5852B-CCFR-256	Tray	240 flex/package

<sup>(1)</sup> Availability of these devices upon request, subject to ams approval.

The A-type Flex corresponds to the FUC design.  
The B-type Flex corresponds to the FZC design.

### 3 Tape & Reel Information

Figure 3:  
Reel Dimensions

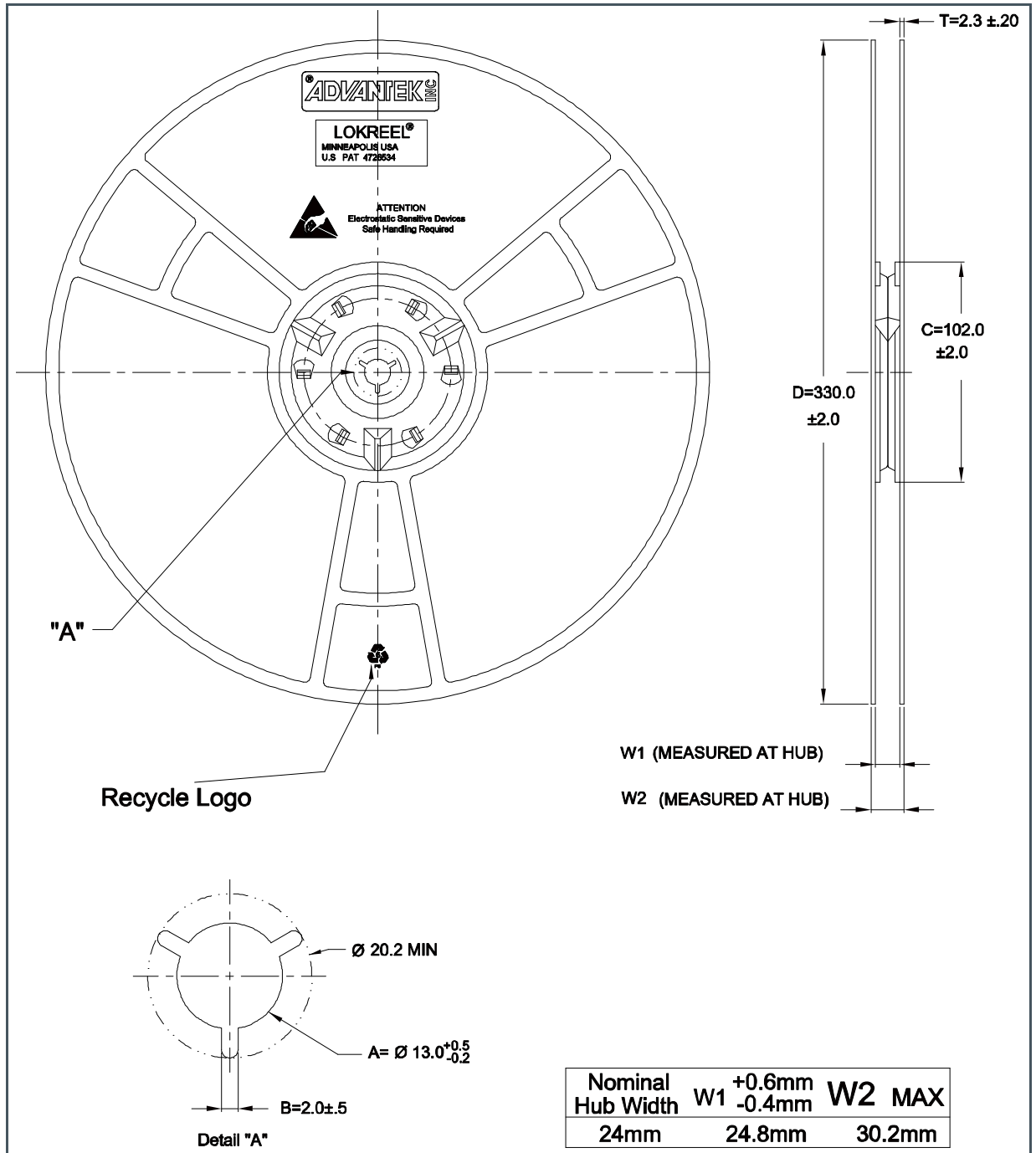

(1) All dimensions in mm



## 4 Revision Information

Document Status	Product Status	Definition
Product Preview	Pre-Development	Information in this datasheet is based on product ideas in the planning phase of development. All specifications are design goals without any warranty and are subject to change without notice
Preliminary Datasheet	Pre-Production	Information in this datasheet is based on products in the design, validation or qualification phase of development. The performance and parameters shown in this document are preliminary without any warranty and are subject to change without notice
Datasheet	Production	Information in this datasheet is based on products in ramp-up to full production or full production which conform to specifications in accordance with the terms of ams AG standard warranty as given in the General Terms of Trade
Datasheet (discontinued)	Discontinued	Information in this datasheet is based on products which conform to specifications in accordance with the terms of ams AG standard warranty as given in the General Terms of Trade, but these products have been superseded and should not be used for new designs

Changes from previous version to current revision v1-00	Page
Initial version	

- Page and figure numbers for the previous version may differ from page and figure numbers in the current revision.
- Correction of typographical errors is not explicitly mentioned.

## 5 Legal Information

### Copyrights & Disclaimer

Copyright ams AG, Tobelbader Strasse 30, 8141 Premstaetten, Austria-Europe. Trademarks Registered. All rights reserved. The material herein may not be reproduced, adapted, merged, translated, stored, or used without the prior written consent of the copyright owner.

Devices sold by ams AG are covered by the warranty and patent indemnification provisions appearing in its General Terms of Trade. ams AG makes no warranty, express, statutory, implied, or by description regarding the information set forth herein. ams AG reserves the right to change specifications and prices at any time and without notice. Therefore, prior to designing this product into a system, it is necessary to check with ams AG for current information. This product is intended for use in commercial applications. Applications requiring extended temperature range, unusual environmental requirements, or high reliability applications, such as military, medical life-support or life-sustaining equipment are specifically not recommended without additional processing by ams AG for each application. This product is provided by ams AG "AS IS" and any express or implied warranties, including, but not limited to the implied warranties of merchantability and fitness for a particular purpose are disclaimed.

ams AG shall not be liable to recipient or any third party for any damages, including but not limited to personal injury, property damage, loss of profits, loss of use, interruption of business or indirect, special, incidental or consequential damages, of any kind, in connection with or arising out of the furnishing, performance or use of the technical data herein. No obligation or liability to recipient or any third party shall arise or flow out of ams AG rendering of technical or other services.

### RoHS Compliant & ams Green Statement

**RoHS Compliant:** The term RoHS compliant means that ams AG products fully comply with current RoHS directives. Our semiconductor products do not contain any chemicals for all 6 substance categories plus additional 4 substance categories (per amendment EU 2015/863), including the requirement that lead not exceed 0.1% by weight in homogeneous materials. Where designed to be soldered at high temperatures, RoHS compliant products are suitable for use in specified lead-free processes.

**ams Green (RoHS compliant and no Sb/Br/Cl):** ams Green defines that in addition to RoHS compliance, our products are free of Bromine (Br) and Antimony (Sb) based flame retardants (Br or Sb do not exceed 0.1% by weight in homogeneous material) and do not contain Chlorine (Cl not exceed 0.1% by weight in homogeneous material).

**Important Information:** The information provided in this statement represents ams AG knowledge and belief as of the date that it is provided. ams AG bases its knowledge and belief on information provided by third parties, and makes no representation or warranty as to the accuracy of such information. Efforts are underway to better integrate information from third parties. ams AG has taken and continues to take reasonable steps to provide representative and accurate information but may not have conducted destructive testing or chemical analysis on incoming materials and chemicals. ams AG and ams AG suppliers consider certain information to be proprietary, and thus CAS numbers and other limited information may not be available for release.

### Headquarters

ams AG  
Tobelbader Strasse 30  
8141 Premstaetten  
Austria, Europe  
Tel: +43 (0) 3136 500 0

Please visit our website at [www.ams.com](http://www.ams.com)

Buy our products or get free samples online at [www.ams.com/Products](http://www.ams.com/Products)

Technical Support is available at [www.ams.com/Technical-Support](http://www.ams.com/Technical-Support)

Provide feedback about this document at [www.ams.com/Document-Feedback](http://www.ams.com/Document-Feedback)

For sales offices, distributors and representatives go to [www.ams.com/Contact](http://www.ams.com/Contact)

For further information and requests, e-mail us at [ams\\_sales@ams.com](mailto:ams_sales@ams.com)