

REVISIONS				
SYM	ZONE	ECN, ERN NO.	DATE	APPRD.
A		PROPOSAL	05/11/16	LCHAN

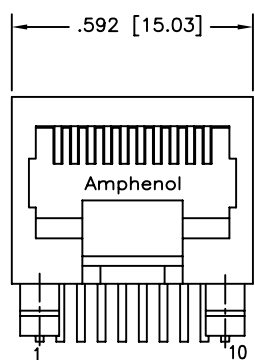

FRONT VIEW

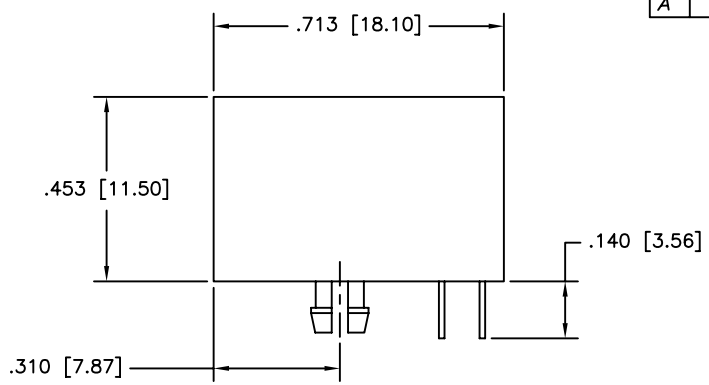

SIDE VIEW

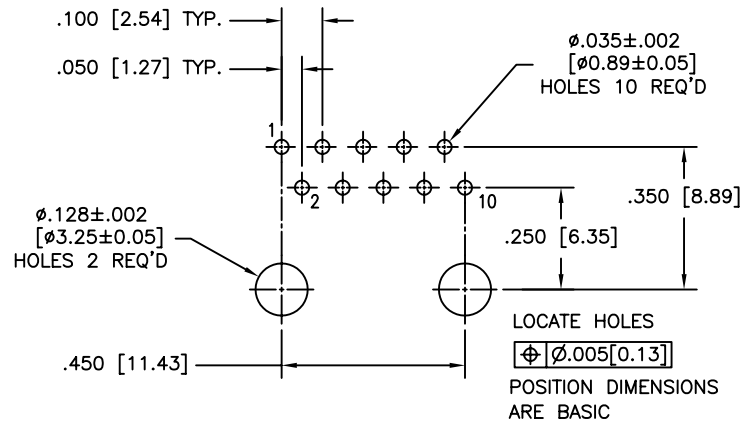

RECOMMENDED P.C.B. LAYOUT
(COMPONENT SIDE OF BOARD)

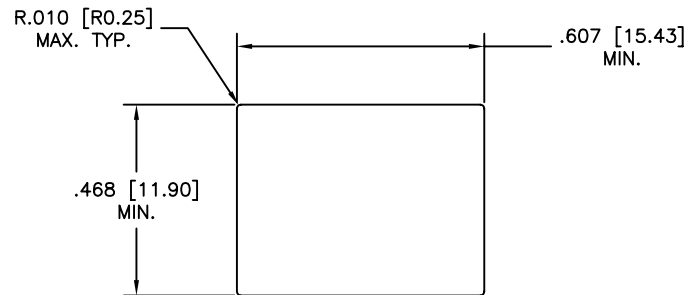

RECOMMENDED PANEL CUTOUT

NOTES:

- HOUSING: HIGH TEMPERATURE THERMOPLASTIC
FLAMMABILITY RATING UL94V-0
- CONTACTS: PHOSPHOR BRONZE
PLATING: REFER TO PART NUMBER FOR GOLD THICKNESS ON MATING SURFACES.
50 μ" [1.27 MICRONS]
MIN. NICKEL UNDERPLATE.
100 μ" [2.54 MICRONS]
MIN. MATTE TIN ON CONTACT TAILS.

AMPHENOL PART NUMBER: RJE05-1AA-0X11

- GOLD PLATING:
- 1 = 6 μ"
 - 2 = 15 μ"
 - 3 = 30 μ"
 - 4 = 50 μ"

THIS DOCUMENT CONTAINS PROPRIETARY INFORMATION AND SUCH INFORMATION MAY NOT BE DISCLOSED TO OTHERS FOR ANY PURPOSE OR USED FOR MANUFACTURING PURPOSES WITHOUT WRITTEN PERMISSION FROM AMPHENOL CANADA CORP.

DRAWN <i>Chigow</i>	DATE 05/11/16	Amphenol Canada Corp.		
DESIGNED				
CHECKED <i>PAULW</i>	DATE 05/11/16	TITLE		
I. E. APPRD.		1 PORT, RJE05 SERIES MODULAR JACK, 10 POSITION, 10 CONTACTS, ULTRA LOW PROFILE, WITHOUT SHIELD -RoHS COMPLIANT		
Q. A. APPRD.		DWG	DRAWING NO.	REV.
DWG. APPRD.			P-RJE05-1AA-0X11	A
ENG. REL. NO.		SCALE	WT. -----	SURF. -----
REF.		DIMENSIONS ARE IN INCHES (mm)	CODE ID. NO. 03554	SHEET 1 of 1