

FRONT VIEW
SHOWING FOR RJE73-188-00XX1-0X
(WITH SHIELD TABS)

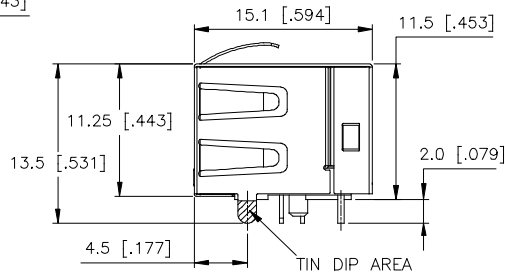

SIDE VIEW

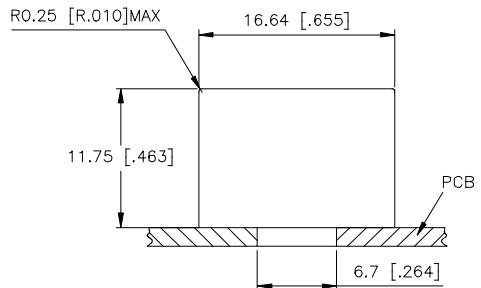

RECOMMENDED CUTOUT

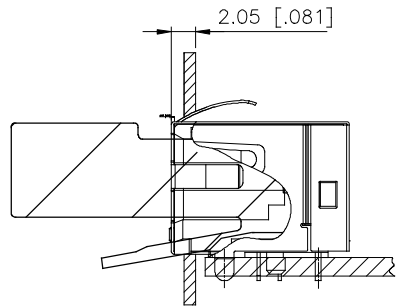

SHOWING CONNECTOR ON PCB

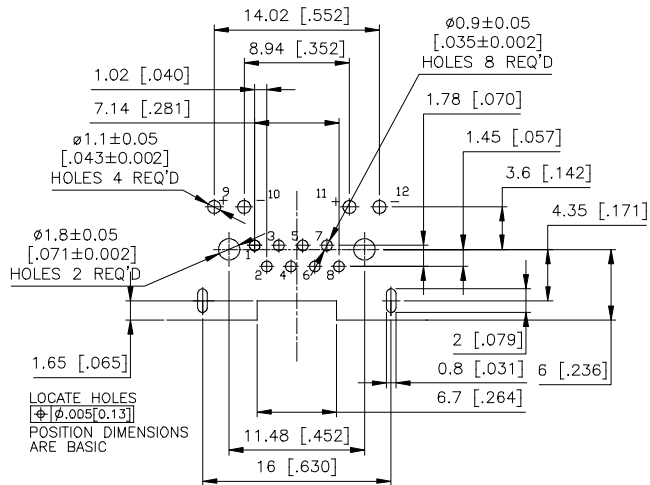

RECOMMENDED P.C.B LAYOUT
(COMPONENT SIDE OF BOARD
TOLERANCES: +/- .05[.002])

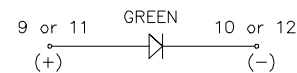

FOR SINGLE COLOR
(GREEN, YELLOW OR RED)

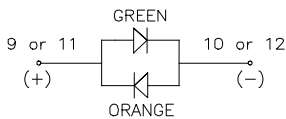

FOR BI-COLOR
(GREEN/ORANGE, GREEN/YELLOW
AND GREEN/RED)

LED SCHEMATIC



REVISIONS				
REV	DESCRIPTION, ECN, EAR NO.	DATE	APP'D	
A	PROPOSAL	FEB24/12	L.CHAN	
B	PROPOSAL	MAR05/12	L.CHAN	
C	CORRECT PCB LAYOUT	SEP12/12	L.CHAN	
D	ADD LED OPTIONS	MAY08/13	L.CHAN	
E	ADD LED OPTIONS	AUG02/13	L.CHAN	
F	ADD TABS DIMENSION AND UPDATE P/N DEFINITION	FEB24/17	L.CHAN	
G	FIX LED HOLE DIMENSION	APR18/18	L.CHAN	
H	ADD LED OPERATING TEMPERATURE	JUL31/18	L.CHAN	
J	UPDATE THE FRONT VIEW	JUL09/19	L.CHAN	

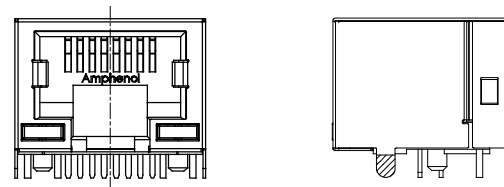

SHOWING FOR RJE73-188-00XX0-0X
(WITHOUT SHIELD TABS)

1. MATERIALS:

PLASTIC HOUSING: HIGH TEMPERATURE THERMOPLASTIC
FLAMMABILITY RATING UL 94V-0
COLOUR: BLACK

CONTACTS:

PHOSPHOR BRONZE
PLATING: SELECTIVE GOLD PLATING ON MATING SURFACES
SEE AMPHENOL PART NUMBER FOR DETAIL.
50 μ" [1.27 MICRONS]
MIN. NICKEL UNDERPLATE
100 μ" [2.54 MICRONS]
MIN. TIN ON CONTACT TAILS.

SHIELD:

STAINLESS STEEL WITH TIN DIP ON SOLDER TAIL

2. UNLESS OTHERWISE SPECIFIED DIMENSIONS ARE IN MILLIMETERS
TOLERANCES ARE: 0.30MM.

MATES WITH MODULAR PLUG CONFORMING TO FCC PART 68, SUBPART F.
RECOMMENDED SOLDER PROCESS: WAVE SOLDER, PEAK TEMPERATURE
260° FOR 8~10 SECOND.

AMPHENOL PART NUMBER: RJE73-188-00XXX-0X

GOLD PLATING OPTION
1=6u" GOLD PLATING
2=15u" GOLD PLATING
3=30u" GOLD PLATING
4=50u" GOLD PLATING

ONLY USED FOR "W" OPTIONS
USED IN FIRST LED CODE
REFER TO LED OPTIONS
DRAWING FOR ORDERING CODES

GROUND TABS OPTION
0=WITHOUT TAB
1=WITH SIDE AND TOP TABS

UNLESS SPECIFIED OTHERWISE	DRAWN Edwin.Qu	FEB24/12
PRIMARY UNITS INCHES	CHECKED L.Chan	FEB24/12
SECONDARY MILLIMETERS	M.E. APP'D	
REFERENCE IN PARENTHESES	Q.A. APP'D	
GENERAL TOLERANCES	DWG APP'D A.G	FEB24/12
1 DECIMAL PLACE	ENG. REL NO.	
2 DECIMAL PLACES	REF.	
3 DECIMAL PLACES ±.015	THIRD ANGLE PROJECTION	DO NOT SCALE DRAWING
ANGULAR DEGREES ±1.5°		

Amphenol Canada Corp.
Commercial Products

MODULAR JACK, 8 POSITIONS, 8 CONTACTS,
SHIELDED, WITH LEDs, WITH TAPE & REEL
PACKAGING, -RoHS COMPLIANT

DWG NO.	P-RJE73-188-00XXX-0X	REV J
CODE ID NO. 03554	DWG SIZE X	SCALE N/A
SHEET 1 OF 2		

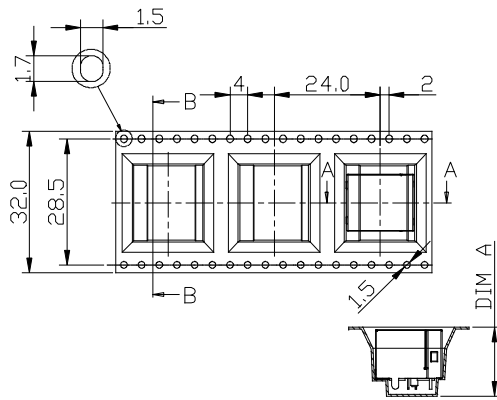

SECTION A-A

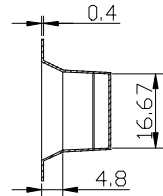

SECTION B-B

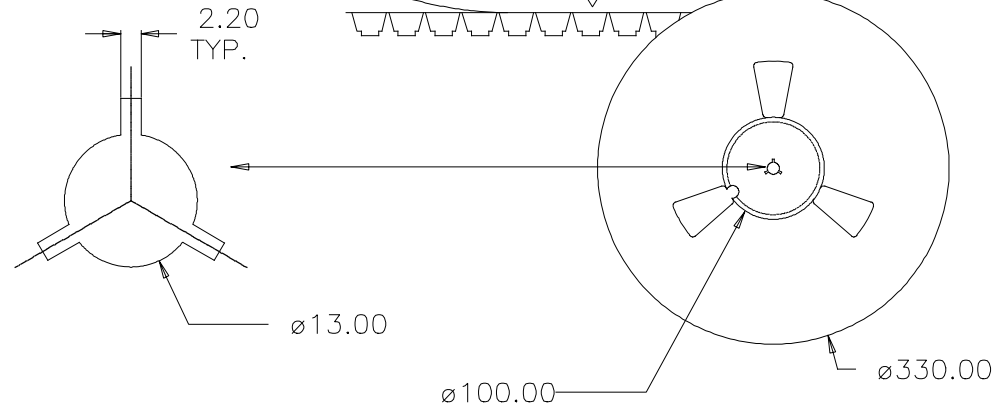

DIRECTION OF CONNECTOR
LOADED INTO MACHINE

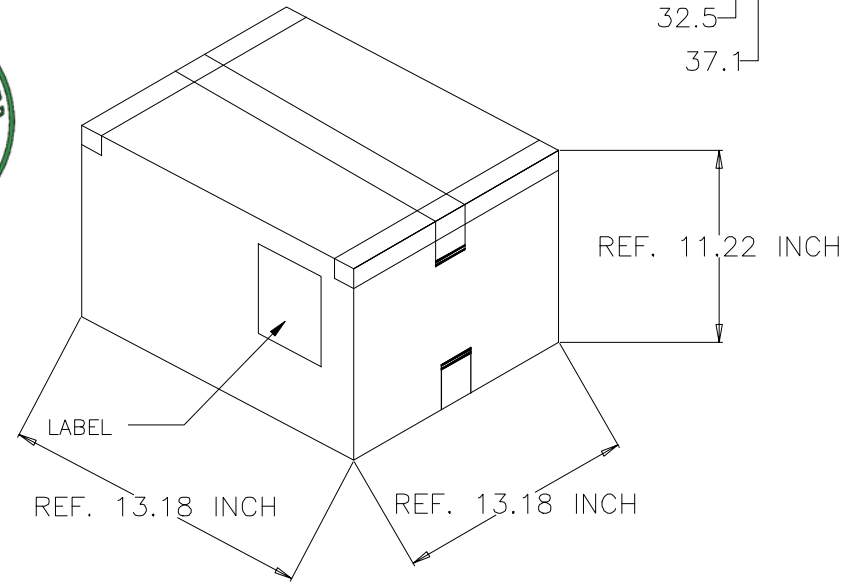
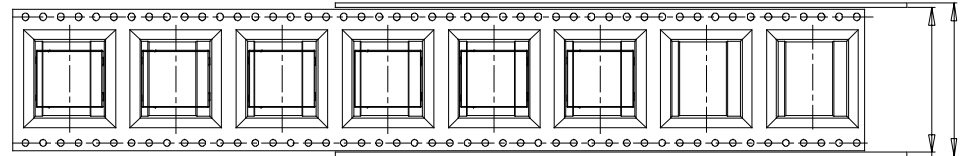

PACKAGING NOTES:

1. 8 EMPTY CAVITIES FOR TAPE LEADER AND 15 EMPTY CAVITIES FOR TAPE TRAILER.
2. A FULLY LOADED CARTON SHOULD CONTAIN 7 REELS OF CONNECTOR.

RJE73-188-00XX0-0X	WITHOUT TAB	180PCS	1260PCS	15.18mm
RJE73-188-00XX1-0X	WITH TABS	160PCS	1120PCS	16.02mm
AMPHENOL PART NUMBER	TAB OPTION	QUANTITY PER REEL	QUANTITY PER CARTON	DIM A

UNLESS SPECIFIED OTHERWISE	DRAWN Edwin.Qu	FEB24/12
PRIMARY UNITS INCHES	CHECKED L.Chan	FEB24/12
SECONDARY MILLIMETERS	M.E. APP'D	
REFERENCE IN PARENTHESES	Q.A. APP'D	
GENERAL TOLERANCES	DWG APP'D A.G	FEB24/12
1 DECIMAL PLACE	ENG. REL. NO.	
2 DECIMAL PLACES	REF.	
3 DECIMAL PLACES ±.015		
ANGULAR DEGREES ±1.5°	THIRD ANGLE PROJECTION	DO NOT SCALE DRAWING

Amphenol Canada Corp. Commercial Products	
MODULAR JACK, 8 POSITIONS, 8 CONTACTS, SHIELDED, WITH LEDs, WITH TAPE & REEL PACKAGING, -RoHS COMPLIANT	
DWG NO. P-RJE73-188-00XXX-0X	REV J
CODE ID NO. 03554	DWG SIZE X SCALE N/A SHEET 2 OF 2

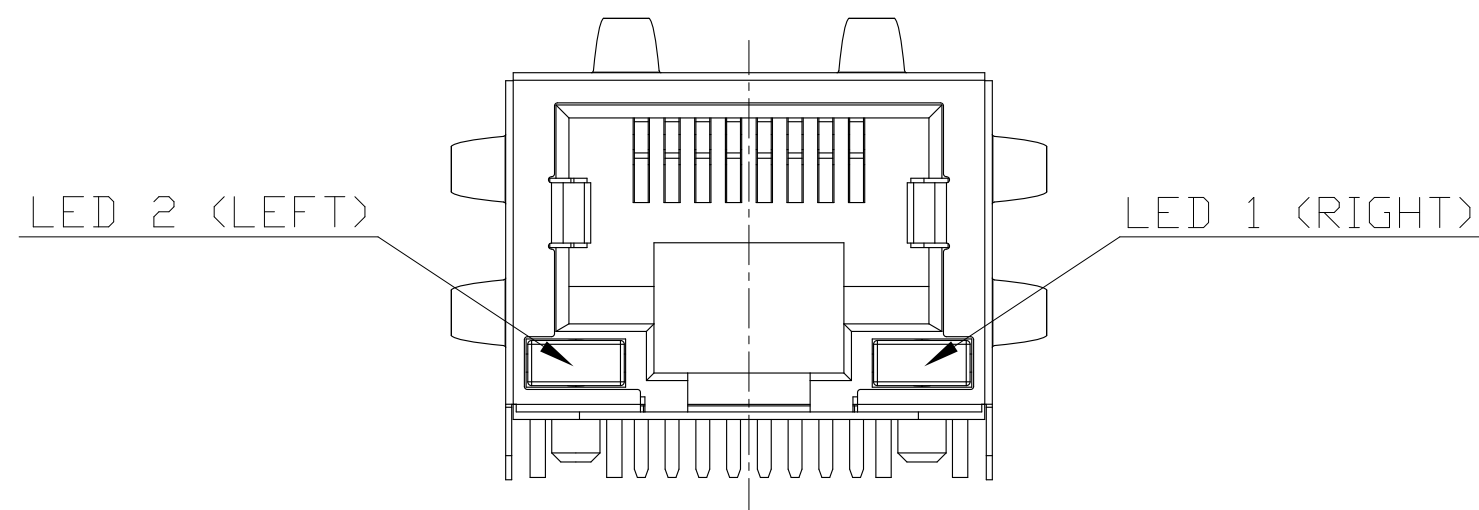

REVISIONS				
SYM	ZONE	ECN, ERN NO.	DATE	APPRD.
A		PROPOSAL	MAR14/2012	L.CHAN
B		ADD LED OPTION	AUG02/2013	L.CHAN

TYPICAL FOR SINGLE



EXAMPLE:
PART NUMBER: RJE73-188-00XXX

LED COLOR CODE

CODE	LED 2 (LEFT)	LED 1 (RIGHT)	CODE	LED 2 (LEFT)	LED 1 (RIGHT)	CODE	LED 2 (LEFT)	LED 1 (RIGHT)
0	BLOCKED	BLOCKED	9	GREEN	BLOCKED	J	BiC RD/GR	YELLOW
1	YELLOW	GREEN	A	BiC GR/YE	BiC GR/YE	K	YELLOW	BiC GR/OR
2	BLOCKED	GREEN	B	BiC RD/GR	BiC RD/GR	L	BiC GR/YE	RED
3	YELLOW	BLOCKED	C	BiC RD/GR	BiC GR/YE	M	RED	YELLOW
4	GREEN	YELLOW	D	GREEN	BiC GR/YE	N	BiC GR/RD	BiC GR/YE
5	GREEN	GREEN	E	YELLOW	BiC GR/YE	P	GREEN	BiC RD/GR
6	YELLOW	YELLOW	F	BiC GR/YE	YELLOW	R	BiC GR/OR	GREEN
7	RED	GREEN	G	BiC GR/OR	BiC GR/OR	T	RED	RED
8	GREEN	RED	H	BiC GR/YE	GREEN	V	BiC RD/GR	GREEN
			W	ADDITIONAL	OPTIONS			

LED SPECIFICATIONS:
 FORWARD VOLTAGE: 2.1 VOLTS TYP.
 REVERSE VOLTAGE: 5.0 VOLTS MIN.
 LUMINOUS INTENSITY: 0.5 mCd MIN.
 (AT If=2mA)
 STORAGE TEMPERATURE: -40° TO 85° C
 LEAD SOLDERING TEMPERATURE: 260° C
 (5 SEC, 1/16" FROM CASE)
 PLATING ON TAILS: TIN OR TIN/COPPER
 ALLOY OVER SILVER

PRIMARY COLOR FOR BI-COLOR
 LEDS IN STANDARD ANODE/
 CATHODE CONFIGURATION IS:
 RED-GREEN= RED
 RED-YELLOW= RED
 GREEN-YELLOW= GREEN
 GREEN-ORANGE= GREEN

EXAMPLE OF ADDITIONAL LED OPTIONS:

PART NUMBER RJE73-188-00XWX-0X

↑ ADDITIONAL LED COLOR CODE
 ↑ DENOTES ADDITIONAL LED OPTIONS TO BE USED

CODE	LED 2 (LEFT)	LED 1 (RIGHT)	CODE	LED 2 (LEFT)	LED 1 (RIGHT)	CODE	LED 2 (LEFT)	LED 1 (RIGHT)
0	DO NOT USE		5	BLOCKED	YELLOW	E	GREEN	ORANGE
1	RED	BLOCKED	6	RED	BiC RD/GR	A	LOWC YE	LOWC YE
2	BiC GR/OR	YELLOW	7	BLOCKED	BiC RD/GR	B	LOWC YE	LOWC GR
3	YELLOW	RED	8	BiC RD/GR	BLOCKED	C	LOWC GR	LOWC YE
4	BLOCKED	RED	9	BiC GR/YE	BLOCKED	D	LOWC GR	LOWC GR
						M	RED	YELLOW
						N	GREEN	BiC GR/OR
						E	GREEN	ORANGE
						F	ORANGE	GREEN
						P	BiC RE/YE	GREEN
						R	BiC RD/YE	BiC RD/YE
						T	BiC GR/YE	BiC RE/GR
						G	GREEN	BiC OR/GR

LEGEND

BiC=BI-COLOR LED
 LOWC=LOW CURRENT LED
 YE=YELLOW
 GR=GREEN
 RD=RED
 OR=ORANGE

NOTE:

THE TWO DIGITS PRECEDING THE
 ADDITIONAL LED CODE MUST BE
 USED IN THE PART NUMBER, WHEN
 ORDERING ANY OF THE ADDITIONAL
 LED OPTIONS.

DRAWN	Edwin.Qu	DATE	MAR14/2012
DESIGNED			
CHECKED	L.Chan	DATE	MAR14/2012
I. E. APPRD.			
Q. A. APPRD.			
DWG. APPRD.	Adrian	DATE	MAR14/2012
ENG. REL. NO.			
REF.			
DIMENSIONS ARE IN	CODE ID. NO.		
mm[INCHES]	03554		

Amphenol Canada Corp.			
TITLE			
LED OPTIONS FOR RJE73			
DWG	DRAWING NO.	REV.	
	P-RJE73-LEDs	B	
SCALE	WT. -----	SURF. -----	SHEET 1 OF 1

THIS DOCUMENT CONTAINS PROPRIETARY INFORMATION AND SUCH INFORMATION
 MAY NOT BE DISCLOSED TO OTHERS FOR ANY PURPOSE OR USED FOR MANUFACTURING
 PURPOSES WITHOUT WRITTEN PERMISSION FROM AMPHENOL CANADA CORP.