

REVISIONS					
REV	ECO	DESCRIPTION	DATE	BY	APPR
A1	--	RELEASED DRAWING	Jun-14-16	Ben	Tommy
A2	--	UPDATE NOTES	Jun-20-17	Nick	Tommy
A3	--	UPDATE DRAWING	Mar-19-2018	White	Tommy

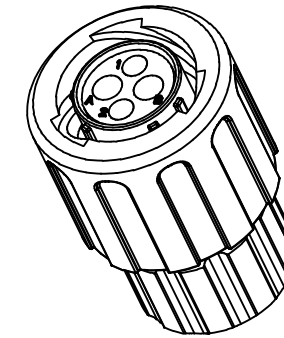
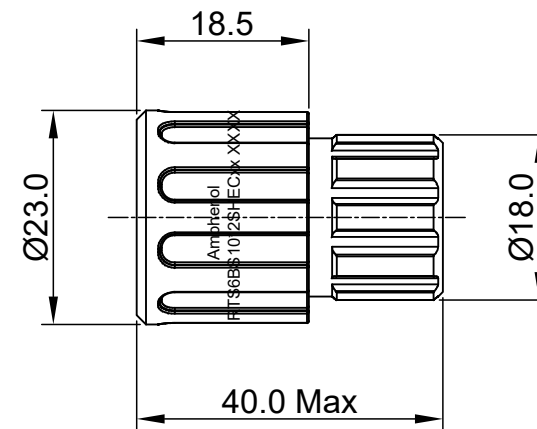
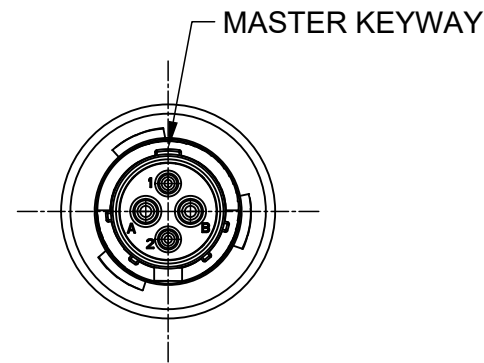

NOTES : (UNLESS OTHERWISE SPECIFIED)

1. MATERIAL :

- SHELL : THERMOPLASTIC , UL94 V-0.
- INSERT : THERMOPLASTIC , UL94 V-0.
- COUPLING NUT : THERMOPLASTIC , UL94 V-0.
- O-RING : NBR/SILICONE RUBBER.
- WASHER : SILICONE RUBBER.
- END CAP : THERMOPLASTIC , UL94 V-0.
- PLASTIC RING : THERMOPLASTIC , UL94 V-0.
- WIRE SEAL : SILICONE RUBBER.

2. SPECIFICATIONS :

- 2.1 RATED CURRENT :
 - 2.1.1 16# CONTACT 13A (MAX) .
 - 2.1.2 20# CONTACT 5A (MAX).
- 2.2 RATED VOLTAGE : 500V(AC/DC).
- 2.3 OPERATING TEMPERATURE : SEE TABLE.
- 2.4 DIELECTRIC WITHSTANDING VOLTAGE : LESS THAN 2 MILLIAMPS CURRENT LEAKAGE@2000 VOLTS AC.
- 2.5 INSULATION RESISTANCE : 5000 MEGOHMS MIN.
- 2.6 IP CLASS : IP67 AND IP69K IN THE MATED CONDITION, WIRE SEALS FULLY POPULATED.
- 2.7 MATING CYCLES DURABILITY : 500 CYCLES MIN.
- 2.8 RoHS COMPLIANT.

3. SUITABLE CONTACTS : 16# & 20# CONTACTS.

4. ALL DIMENSIONS ARE FOR REFERENCE USE ONLY.

5. CONTACT SIZE AND REAR SEAL WIRE RANGE :

CONTACT SIZE	MIN. INSUL O.D.	MAX. INSUL O.D.	WIRE RANGE
16#	Ø2.0mm	Ø3.2mm	14 - 24AWG
20#	Ø1.6mm	Ø2.6mm	20 - 30AWG

SEALING PLUGS CAN BE PURCHASED SEPARATELY

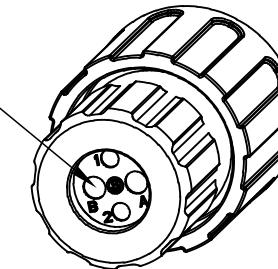

KEY	PART NUMBER	
	-40°C ~ 105°C	-40°C ~ 125°C
N	RTS6BS10N2SHEC	RTS6BS10N2SHEC03

QUANTITY	PART NUMBER	DESCRIPTION	ITEM										
MATERIALS LIST													
UNLESS OTHERWISE SPECIFIED: 1) All dimensions are in metric(mm). 2) Tolerances are as follows: 1 PL DEC ±0.30 2 PL DEC ±0.15 3 PL DEC ±0.08 Fractions ±1/64 Angles ±1° 3) Note reference =		<table border="1"> <thead> <tr> <th>SIGNATURES</th> <th>DATE</th> </tr> </thead> <tbody> <tr> <td>DRAWN: White</td> <td>Mar-19-2018</td> </tr> <tr> <td>CHECKED: Tod</td> <td>Mar-19-2018</td> </tr> <tr> <td>ENGINEER:</td> <td></td> </tr> <tr> <td>APPROVAL: Tommy</td> <td>Mar-19-2018</td> </tr> </tbody> </table>		SIGNATURES	DATE	DRAWN: White	Mar-19-2018	CHECKED: Tod	Mar-19-2018	ENGINEER:		APPROVAL: Tommy	Mar-19-2018
SIGNATURES	DATE												
DRAWN: White	Mar-19-2018												
CHECKED: Tod	Mar-19-2018												
ENGINEER:													
APPROVAL: Tommy	Mar-19-2018												
MATERIAL SPECIFICATIONS:		<p style="text-align: center;">Amphenol</p> <p>Sine Systems - www.amphenol-sine.com 44724 Morley Drive Clinton Township, MI 48036</p>											
PROCESS SPECIFICATIONS:		<p>ECO-MATE, PLUG, END CAP, SIZE 10,4 POS(2+2), SOCKET</p>											
NEXT ASSY:		<table border="1"> <thead> <tr> <th>SIZE</th> <th>TYPE</th> <th>DWG NO:</th> <th>REVISION</th> </tr> </thead> <tbody> <tr> <td>B</td> <td>C-</td> <td>RTS6BS10*2SHECxx</td> <td>A3</td> </tr> </tbody> </table>		SIZE	TYPE	DWG NO:	REVISION	B	C-	RTS6BS10*2SHECxx	A3		
SIZE	TYPE	DWG NO:	REVISION										
B	C-	RTS6BS10*2SHECxx	A3										
SCALE: NONE		SHEET 1 OF 1											

TITLE: ECO-MATE, PLUG, END CAP, SIZE 10,4 POS(2+2), SOCKET

DWG NO: RTS6BS10*2SHECxx

REV: A3

SH: 1

OF: 1