

REVISIONS					
REV	ECO	DESCRIPTION	DATE	BY	APPR
A1	--	FIRST RELEASED	Jun.15,2016	Drack	Tommy
A2	--	UPDATE NOTES	Jun-21-2017	Nick	Tommy
A3	--	UPDATE DRAWING	Mar-19-2018	White	Tommy

MASTER KEYWAY

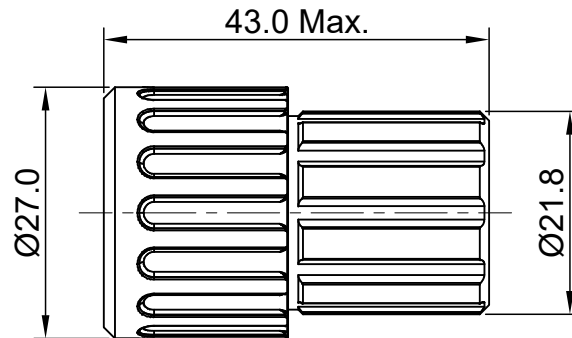

SEALING PLUGS CAN BE PURCHASED SEPARATELY

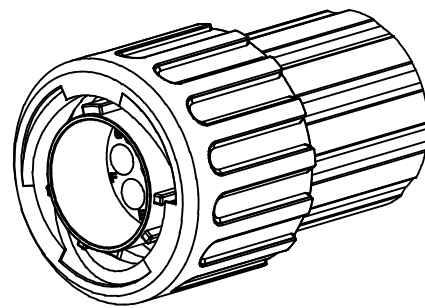
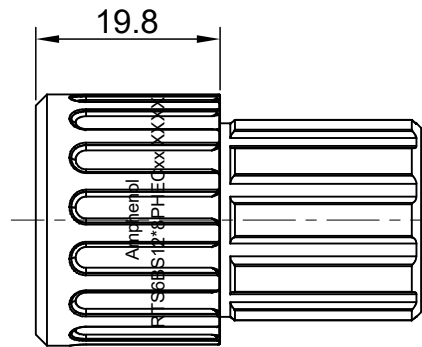
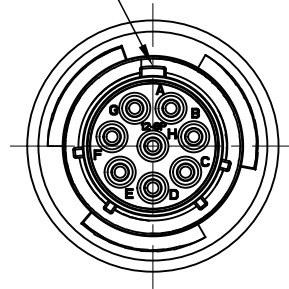
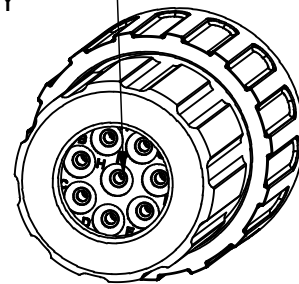

KEY	PART NUMBER	
	-40°C ~ 105°C	-40°C ~ 125°C
N	RTS6BS12N8PHEC	RTS6BS12N8PHEC03

NOTES : (UNLESS OTHERWISE SPECIFIED)

- MATERIAL :
 - SHELL : THERMOPLASTIC , UL94 V-0.
 - INSERT : THERMOPLASTIC , UL94 V-0.
 - COUPLING NUT : THERMOPLASTIC , UL94 V-0.
 - O-RING : NBR OR SILICONE RUBBER.
 - WASHER : SILICONE RUBBER.
 - END CAP : THERMOPLASTIC , UL94 V-0.
 - PLASTIC RING: THERMOPLASTIC , UL94 V-0.
 - WIRE SEAL : SILICONE RUBBER.
- SPECIFICATIONS :
 - 2.1, RATED CURRENT : 13A (MAX).
 - 2.2, RATED VOLTAGE : 500V(AC/DC).
 - 2.3, OPERATING TEMPERATURE : SEE TABLE.
 - 2.4, DIELECTRIC WITHSTANDING VOLTAGE : LESS THAN 2 MILLIAMPS CURRENT LEAKAGE@2000 VOLTS AC.
 - 2.5, INSULATION RESISTANCE : 5000 MEGOHMS MIN.
 - 2.6, IP-CLASS : IP67 AND IP69K IN THE MATED CONDITION, WIRE SEALS FULLY POPULATED.
 - 2.7, MATING CYCLES DURABILITY : 500 CYCLES MIN.
 - 2.8, RoHS COMPLIANT.
- SUITABLE CONTACTS : 16# CONTACTS.
- ALL DIMENSIONS ARE FOR REFERENCE USE ONLY.

QUANTITY	PART NUMBER	DESCRIPTION	ITEM
MATERIALS LIST			
UNLESS OTHERWISE SPECIFIED 1) All dimensions are in metric(mm). 2) Tolerances are as follows: 1 PL DEC ±0.30 2 PL DEC ±0.15 3 PL DEC ±0.08 3) Note reference =		SIGNATURES DRAWN: White CHECKED: Tod ENGINEER: APPROVAL: Tommy	DATE Mar-19-2018 Mar-19-2018 Mar-19-2018
MATERIAL SPECIFICATIONS:		 Sine Systems - www.amphenol-sine.com 44724 Morley Drive Clinton Township, MI 48036	
PROCESS SPECIFICATIONS:		CUSTOMER: ECO-MATE, PLUG, END CAP, 8POS, PIN CONTACT, SIZE 12	
NEXT ASSY:		THIS DRAWING IS SUPPLIED FOR INFORMATION ONLY. DESIGN FEATURES, SPECIFICATIONS AND PERFORMANCE DATA SHOWN HEREON ARE THE PROPERTY OF THE AMPHENOL CORPORATION. NO RIGHTS OF REPRODUCTION ARE IMPLIED. ALL DIMENSIONS ARE SUBJECT TO NORMAL MANUFACTURING VARIATIONS.	SIZE: B C- TYPE: NONE DWG NO: RTS6BS12*8PHECxx REVISION: A3
SCALE: NONE			SHEET 1 OF 1

TITLE: ECO-MATE, PLUG, END CAP, 8POS, PIN CONTACT, SIZE 12
 DWG NO: RTS6BS12*8PHECxx
 REV: A3
 SH: 1
 OF: 1