

Overview

Amphenol RF high frequency SMA end launch connectors offer excellent VSWR performance up to 26.5 GHz. These connectors feature an optimized end launch design with either through-hole legs or traditional slide-on mounting legs that make them an ideal PCB connector solution for high frequency applications.

Features and Benefits

- Through hole and traditional edge launch options available
- Available for multiple different PCB thicknesses
- Custom solutions available for optimization to customer-specific PCB launches

Applications

- Cellular/Broadband Amplifiers
- Microwave Filters
- Wireless Infrastructure
- Remote Sensing and Metering
- GPS Antennas
- Radar Systems
- High Speed Routers and Switches
- Automated Test Equipment
- RFID

Ordering Information



P/N 901-10510-1

Through Hole

Part Number	Pin Diameter	Flange	Leg Length	Leg Type
901-10510-1	0.010"	Square	0.118"	Standard
901-10510-2	0.010"	Round w/ Flats	0.093"	Standard
901-10510-3	0.010"	Round w/ Flats	0.093"	Beveled
901-10512-1	0.015"	Square	0.118"	Standard
901-10512-2	0.015"	Round w/ Flats	0.093"	Standard
901-10512-3	0.015"	Round w/ Flats	0.093"	Beveled



P/N 901-10511-3

Traditional (Slide-On)

Part Number	Pin Diameter	Flange	PCB Thickness	Leg Type
901-10511-1	0.010"	Square	0.062"	Standard
901-10511-2	0.010"	Round w/ Flats	0.062"	Standard
901-10511-3	0.010"	Round w/ Flats	0.062"	Beveled
901-10513-1	0.015"	Square	0.062"	Standard
901-10513-2	0.015"	Round w/ Flats	0.062"	Standard
901-10513-3	0.015"	Round w/ Flats	0.062"	Beveled

Amphenol RF

Four Old Newtown Road
Danbury, CT 06810

For more information visit www.amphenolrf.com
or call 800.627.7100

Amphenol® RF

Technical Specifications

Electrical	
Impedance	50 Ω
Frequency range	0-26.5 GHz
Contact Resistance	Center Contact ≤3 mΩ
	Outer Contact ≤2 mΩ
Voltage Rating (Sea Level)	170 VRMS
Insulation Resistance	1000 MΩ min

Environmental	
Temperature range	-65 °C to +165 °C
Thermal shock	MIL-STD-202, Method 107, Condition B
Vibration	MIL-STD-202, Method 204, Condition D
Mechanical Shock	MIL-STD-202, Method 213, Condition I
Humidity	MIL-STD-202, Method 106

Mechanical	
Mating Torque	7 to 10 inch-pounds
Engagement force	2 inch-pounds maximum
Disengagement force	2 inch-pounds maximum
Durability	500 cycles min

Typical PCB Layouts

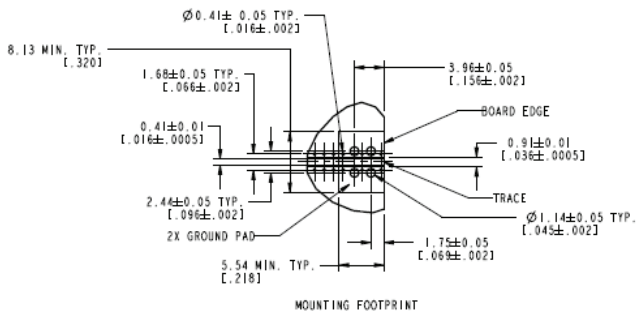

Through-Hole Style Connectors

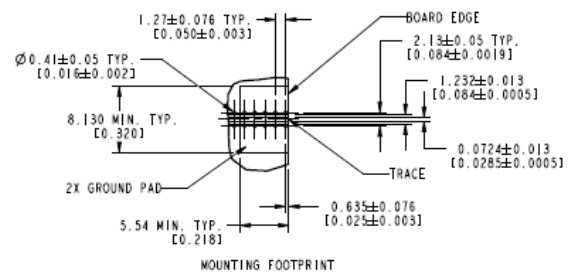

Traditional Edge Mount Style Connectors

Amphenol RF
 Four Old Newtown Road
 Danbury, CT 06810

For more information visit www.amphenorlf.com
 or call 800.627.7100