

Amphenol Tuchel Industrial GmbH Postfach 1110 74001 Heilbronn

TTI Inc.  
Ganghoferstraße 34  
82216 Maisach-Gernlinden

**Amphenol Tuchel Industrial GmbH**  
August-Haeusser-Strasse 10  
74080 Heilbronn / Germany

Tel.: 07131 929 337

[www.industrial-amphenol.de](http://www.industrial-amphenol.de)

5. April 2022

### PCN for wedge locks AW4S & AW6S

Dear Sir or Madam,

In an attempt to constantly improve our high degree of customer satisfaction, we decided to modify the ribs of our wedge locks to improve the overall product performance and function.

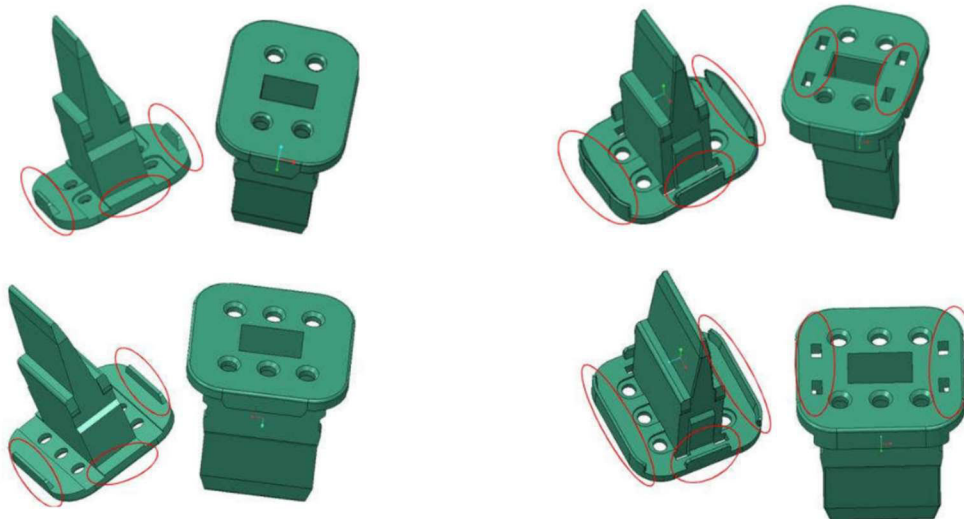

Before Change

After Change

Best regards,

**Amphenol Tuchel Industrial GmbH**

Ines Rodrigo  
Product Manager Industrial

Enclosures:  
Drawing C-AW4S\_REV\_A6  
Drawing C-AW6S\_REV\_A5

**Geschäftsführer:**

Joachim Schmidt,  
Joerg Kersten,  
Craig A. Lampo,  
Adam Norwitt

**Sitz der Gesellschaft:**

Heilbronn / Deutschland  
Amtsgericht Stuttgart, HRB 755446

REVISIONS					
REV	ECO	DESCRIPTION	DATE	BY	APPR
A3	-	RELEASE NEW DWG FORMAT	18/SEP/13	DRP	
A4	-	UPDATE DRAWING	10/MAY/19	JOE	TOMMY
A5	C1437S	INCREASE LIMIT RIBS	22/SEP/21	RONALD	TOMMY

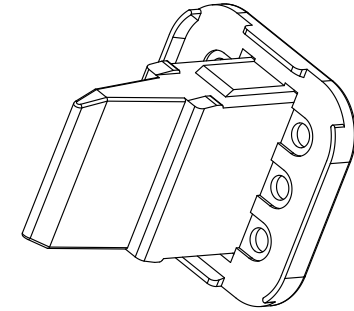
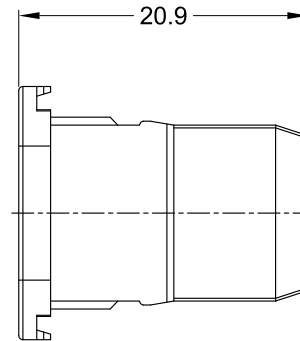
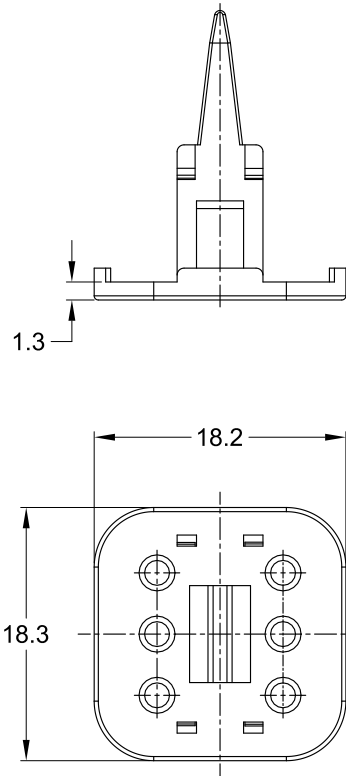

TITLE: S-WEDGELOCK, 6 POSITION, AT SERIES  
 DWG NO.: AW6S  
 REV: A5  
 SH: 1  
 OF: 1

NOTES: UNLESS OTHERWISE SPECIFIED

1. MATERIAL: THERMOPLASTIC; COLOR: GREEN
2. RoHS COMPLIANT
3. CAVITIES: 6
4. KEYED: N/A
5. USE WITH CONNECTORS AT06-6S\*  
(\* = MODIFICATIONS AND COLORS)
6. ALL DIMENSIONS ARE FOR REFERENCE USE ONLY.

QUANTITY	AW6S	DESCRIPTION	ITEM
	PART NUMBER		
<b>MATERIALS LIST</b>			
<b>UNLESS OTHERWISE SPECIFIED:</b> 1) All dimensions are in metric (mm). 2) Tolerances are as follows: 1 PL DEC ±0.30   Fractions ±1/64 2 PL DEC ±0.15   Angles ±1° 3 PL DEC ±0.08 3) Note reference =		SIGNATURES    DATE DRAWN: RONALD    22/SEP/21 CHECKED: ORION    23/SEP/21 ENGINEER: APPROVAL: TOMMY    24/SEP/21 CUSTOMER:	
MATERIAL SPECIFICATIONS:		<div style="text-align: center;"> <h1>Amphenol</h1> <p>Sine Systems - www.amphenol-sine.com            44724 Morley Drive            Clinton Township, MI 48036</p> </div> <p>S-WEDGELOCK, 6 POS ITION, AT SERIES</p>	
PROCESS SPECIFICATIONS:			
NEXT ASSY:		THIS DRAWING IS SUPPLIED FOR INFORMATION ONLY. DESIGN FEATURES, SPECIFICATIONS AND PERFORMANCE DATA SHOWN HEREON ARE THE PROPERTY OF THE AMPHENOL CORPORATION. NO RIGHTS OF REPRODUCTION ARE IMPLIED. ALL DIMENSIONS ARE SUBJECT TO NORMAL MANUFACTURING VARIATIONS.	SIZE: <b>B C-</b> SCALE: <b>NONE</b>
		DWG NO: <b>AW6S</b> SHEET <b>1</b> OF <b>1</b>	REVISION: <b>A5</b>

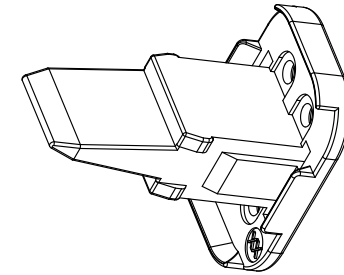
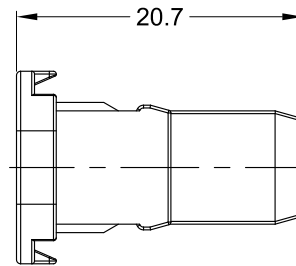
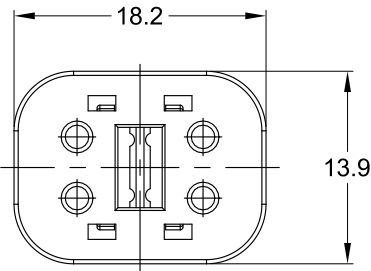
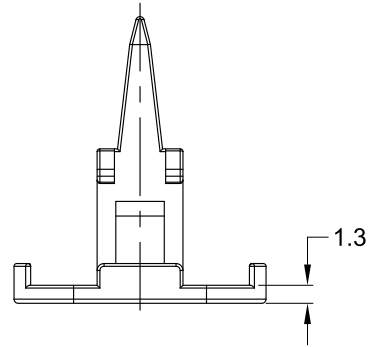

REVISIONS					
REV	ECO	DESCRIPTION	DATE	BY	APPR
A3	-	RELEASE NEW DWG FORMAT	18/SEP/13	DRP	
A4	-	UPDATE DRAWING	10/MAY/19	JOE	TOMMY
A5	-	ADD NEW COLOR	08/JAN/20	BROOK	TOMMY
A6	C1437S	INCREASE LIMIT RIBS	22/SEP/21	RONALD	TOMMY

NOTES: UNLESS OTHERWISE SPECIFIED

1. MATERIAL: THERMOPLASTIC;  
STANDARD COLOR: GREEN  
OPTIONAL COLOR: ORANG ( P/N : AW4S-ORG )
2. RoHS COMPLIANT
3. CAVITIES: 4
4. KEYED: N/A
5. USE WITH CONNECTORS AT06-4S\*  
( \* = MODIFICATIONS AND/OR COLORS )
6. ALL DIMENSIONS ARE FOR REFERENCE USE ONLY.

QUANTITY	AW4S	DESCRIPTION	ITEM
	PART NUMBER		
<b>MATERIALS LIST</b>			
<b>UNLESS OTHERWISE SPECIFIED:</b> 1) All dimensions are in metric (mm). 2) Tolerances are as follows: 1 PL DEC ±0.30   Fractions ±1/64 2 PL DEC ±0.15   Angles ±1° 3 PL DEC ±0.08 3) Note reference =		<b>SIGNATURES</b> <b>DATE</b> DRAWN: RONALD    22/SEP/21 CHECKED: ORION    23/SEP/21 ENGINEER: APPROVAL: TOMMY    24/SEP/21	<div style="text-align: center;"> <h1>Amphenol</h1> <p>Sine Systems - www.amphenol-sine.com 44724 Morley Drive Clinton Township, MI 48036</p> </div>
<b>MATERIAL SPECIFICATIONS:</b> CUSTOMER:		<b>S-WEDGELOCK, 4 POS ITION, AT SERIES</b>	
<b>PROCESS SPECIFICATIONS:</b>		THIS DRAWING IS SUPPLIED FOR INFORMATION ONLY. DESIGN FEATURES, SPECIFICATIONS AND PERFORMANCE DATA SHOWN HEREON ARE THE PROPERTY OF THE AMPHENOL CORPORATION. NO RIGHTS OF REPRODUCTION ARE IMPLIED. ALL DIMENSIONS ARE SUBJECT TO NORMAL MANUFACTURING VARIATIONS.	SIZE: <b>B C-</b> DWG NO: <b>AW4S</b> REVISION: <b>A6</b>
<b>NEXT ASSY:</b>		SCALE: <b>NONE</b>	SHEET 1 OF 1

TITLE: S-WEDGELOCK, 4 POSITION, AT SERIES  
 DWG NO: AW4S  
 REV: A6  
 SH: 1  
 OF: 1