

Document Title

512K x16 bit Super Low Power and Low Voltage Full CMOS Static RAM

Revision History

Revision No.	History	Date	Remark
0.0	- Initial issue	Apr. 7 2009	Preliminary
1.0	- tDW updated to 40ns	Mar. 2 2010	
2.0	- tDW updated to 25ns (45ns, 55ns), 30ns(70ns)	Oct. 22 2012	

FEATURES

- Process Technology : 0.15 μ m Full CMOS
- Organization : 512K x 16 bit
- Power Supply Voltage : 2.7V ~ 3.6V
- Low Data Retention Voltage : 1.5V(Min.)
- Three state output and TTL Compatible
- Package Type : 48-FPBGA

GENERAL DESCRIPTION

The AS6C8016A families are fabricated by advanced full CMOS process technology. The families support industrial temperature range and Chip Scale Package for user flexibility of system design. The families also support low data retention voltage for battery back- operation with low data retention current.

PRODUCT FAMILY

Product Family	Operating Temperature	Vcc Range	Speed	Power Dissipation		PKG Type
				Standby (I_{SB1} , Typ.)	Operating (I_{CC1} -Max.)	
AS6C8016A-55BIN	Industrial (-40 ~ 85°C)	2.7 ~ 3.6 V	55 ns	2 μ A ¹⁾	4 mA	48-FPBGA

1. Typical values are measured at Vcc=3.3V, T_A=25°C and not 100% tested.

FUNCTIONAL BLOCK DIAGRAM

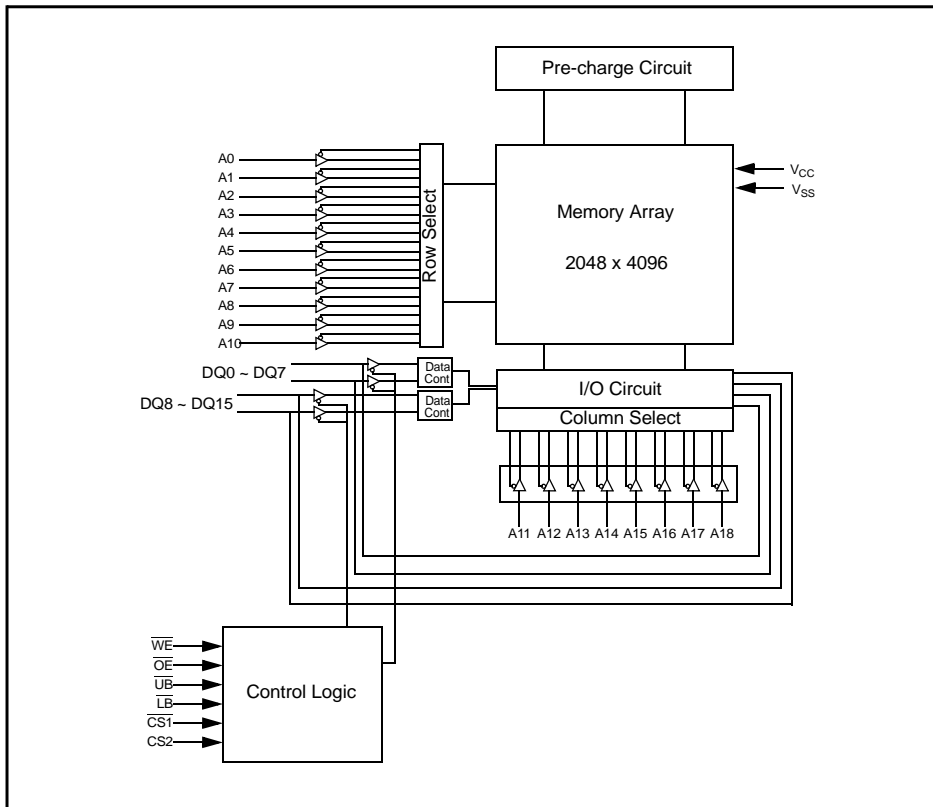

PIN CONFIGURATIONS

FPBGA-48: Top view (ball down)

	1	2	3	4	5	6
A	$\overline{\text{LB}}$	$\overline{\text{OE}}$	A0	A1	A2	CS2
B	DQ8	$\overline{\text{UB}}$	A3	A4	$\overline{\text{CS1}}$	DQ0
C	DQ9	DQ10	A5	A6	DQ1	DQ2
D	V _{SS}	DQ11	A17	A7	DQ3	V _{CC}
E	V _{CC}	DQ12	NC	A16	DQ4	V _{SS}
F	DQ14	DQ13	A14	A15	DQ5	DQ6
G	DQ15	NC	A12	A13	$\overline{\text{WE}}$	DQ7
H	A18	A8	A9	A10	A11	NC

PIN DESCRIPTION

Name	Function	Name	Function
$\overline{\text{CS1}}$, CS2	Chip Select inputs	V _{CC}	Power Supply
$\overline{\text{OE}}$	Output Enable input	V _{SS}	Ground
$\overline{\text{WE}}$	Write Enable input	$\overline{\text{UB}}$	Upper Byte (DQ8~DQ15)
A0~A18	Address inputs	$\overline{\text{LB}}$	Lower Byte (DQ0~DQ7)
DQ0~DQ15	Data inputs/outputs	NC	No Connection

ABSOLUTE MAXIMUM RATINGS¹⁾

Parameter	Symbol	Ratings	Unit
Voltage on Any Pin Relative to Vss	V_{IN}, V_{OUT}	-0.2 to 4.0	V
Voltage on Vcc supply relative to Vss	V_{CC}	-0.2 to 4.0	V
Power Dissipation	P_D	1.0	W
Operating Temperature	T_A	-40 to 85	°C

1. Stresses greater than those listed under "Absolute Maximum Ratings" may cause permanent damage to the device. Functional operation should be restricted to recommended operating condition. Exposure to absolute maximum rating conditions for extended periods may affect reliability.

FUNCTIONAL DESCRIPTION

CS1	CS2	OE	WE	LB	UB	DQ0~7	DQ8~15	Mode	Power
H	X	X	X	X	X	High-Z	High-Z	Deselected	Stand by
X	L	X	X	X	X	High-Z	High-Z	Deselected	Stand by
X	X	X	X	H	H	High-Z	High-Z	Deselected	Stand by
L	H	H	H	L	X	High-Z	High-Z	Output Disabled	Active
L	H	H	H	X	L	High-Z	High-Z	Output Disabled	Active
L	H	L	H	L	H	Data Out	High-Z	Lower Byte Read	Active
L	H	L	H	H	L	High-Z	Data Out	Upper Byte Read	Active
L	H	L	H	L	L	Data Out	Data Out	Word Read	Active
L	H	X	L	L	H	Data In	High-Z	Lower Byte Write	Active
L	H	X	L	H	L	High-Z	Data In	Upper Byte Write	Active
L	H	X	L	L	L	Data In	Data In	Word Write	Active

NOTE: X means don't care. (Must be low or high state)

RECOMMENDED DC OPERATING CONDITIONS¹⁾

Parameter	Symbol	Min	Typ	Max	Unit
Supply voltage	V_{CC}	2.7	3.3	3.6	V
Ground	V_{SS}	0	0	0	V
Input high voltage	V_{IH}	2.2	-	$V_{CC} + 0.2$ ²⁾	V
Input low voltage	V_{IL}	-0.2 ³⁾	-	0.6	V

1. $T_A = -40$ to 85°C , otherwise specified
2. Overshoot: $V_{CC} + 2.0$ V in case of pulse width ≤ 20 ns
3. Undershoot: -2.0 V in case of pulse width ≤ 20 ns
4. Overshoot and undershoot are sampled, not 100% tested.

CAPACITANCE¹⁾ ($f = 1\text{MHz}$, $T_A = 25^\circ\text{C}$)

Item	Symbol	Test Condition	Min	Max	Unit
Input capacitance	C_{IN}	$V_{IN} = 0\text{V}$	-	8	pF
Input/Output capacitance	C_{IO}	$V_{IO} = 0\text{V}$	-	10	pF

1. Capacitance is sampled, not 100% tested

DC AND OPERATING CHARACTERISTICS

Parameter	Symbol	Test Conditions	Min	Typ	Max	Unit
Input leakage current	I_{LI}	$V_{IN} = V_{SS}$ to V_{CC}	-1	-	1	μA
Output leakage current	I_{LO}	$CS1 = V_{IH}$ or $CS2 = V_{IL}$ or $OE = V_{IH}$ or $WE = V_{IL}$ or $LB = UB = V_{IH}$ $V_{IO} = V_{SS}$ to V_{CC}	-1	-	1	μA
Operating power supply	I_{CC}	$I_{IO} = 0\text{mA}$, $CS1 = V_{IL}$, $CS2 = WE = V_{IH}$, $V_{IN} = V_{IH}$ or V_{IL}	-	-	2	mA
Average operating current	I_{CC1}	Cycle time = $1\mu\text{s}$, 100% duty, $I_{IO} = 0\text{mA}$, $CS1 \leq 0.2\text{V}$, $CS2 \geq V_{CC} - 0.2\text{V}$, $LB \leq 0.2\text{V}$ or/and $UB \leq 0.2\text{V}$, $V_{IN} \leq 0.2\text{V}$ or $V_{IN} \geq V_{CC} - 0.2\text{V}$	-	-	4	mA
	I_{CC2}	Cycle time = Min, $I_{IO} = 0\text{mA}$, 100% duty, $CS1 = V_{IL}$, $CS2 = V_{IH}$, $LB = V_{IL}$ or/and $UB = V_{IL}$, $V_{IN} = V_{IL}$ or V_{IH}	55ns	-	35	mA
Output low voltage	V_{OL}	$I_{OL} = 2.1\text{mA}$	-	-	0.4	V
Output high voltage	V_{OH}	$I_{OH} = -1.0\text{mA}$	2.4	-	-	V
Standby Current (TTL)	I_{SB}	$CS1 = V_{IH}$, $CS2 = V_{IL}$, Other inputs = V_{IH} or V_{IL}	-	-	0.5	mA
Standby Current (CMOS)	I_{SB1}	$CS1 \geq V_{CC} - 0.2\text{V}$, $CS2 \geq V_{CC} - 0.2\text{V}$ ($\overline{CS1}$ controlled) or $0 \leq CS2 \leq 0.2\text{V}$ ($CS2$ controlled), Other inputs = $0 - V_{CC}$ (Typ. condition : $V_{CC} = 3.3\text{V}$ @ 25°C) (Max. condition : $V_{CC} = 3.6\text{V}$ @ 85°C)	LF	-	2 ¹⁾	15 μA

1. Typical values are measured at $V_{CC} = 3.3\text{V}$, $T_A = 25^\circ\text{C}$ and not 100% tested.

AC OPERATING CONDITIONS
Test Conditions (Test Load and Test Input/Output Reference)

Input Pulse Level: 0.4 to 2.4V

Input Rise and Fall Time: 5ns

Input and Output reference Voltage: 1.5V

 Output Load (See right): $CL^{(1)} = 100\text{pF} + 1 \text{ TTL (70nsec)}$

$$CL^{(1)} = 30\text{pF} + 1 \text{ TTL (45ns/55ns)}$$

1. Including scope and Jig capacitance

 2. $R_1=3070\Omega$, $R_2=3150\Omega$

 3. $V_{TM}=2.8\text{V}$

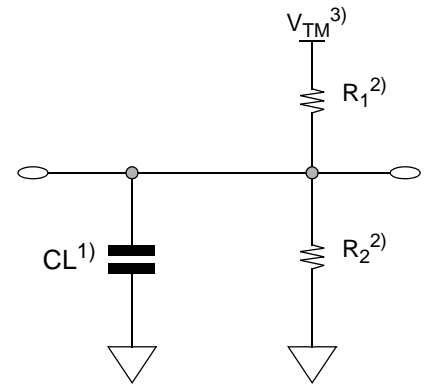
 4. $CL = 5\text{pF} + 1 \text{ TTL (measurement with } t_{LZ}, t_{HZ}, t_{OLZ}, t_{OHZ}, t_{WHZ})$

READ CYCLE ($V_{CC}=2.7$ to 3.6V , $Gnd = 0\text{V}$, $T_A = -40^\circ\text{C}$ to $+85^\circ\text{C}$)

Parameter	Symbol	55ns		Unit
		Min	Max	
Read cycle time	t_{RC}	55	-	ns
Address access time	t_{AA}	-	55	ns
Chip select to output	t_{CO1}, t_{CO2}	-	55	ns
Output enable to valid output	t_{OE}	-	35	ns
\overline{UB} , \overline{LB} access time	t_{BA}		55	ns
Chip <u>select</u> to low-Z output	t_{LZ1}, t_{LZ2}	5	-	ns
\overline{UB} , \overline{LB} enable to low-Z output	t_{BLZ}	5	-	ns
Output enable to low-Z output	t_{OLZ}	5	-	ns
Chip <u>disable</u> to high-Z output	t_{HZ1}, t_{HZ2}	0	20	ns
\overline{UB} , \overline{LB} disable to how-Z output	t_{BHZ}	0	20	ns
Output disable to high-Z output	t_{OHZ}	0	20	ns
Output hold from address change	t_{OH}	10	-	ns

WRITE CYCLE ($V_{CC}=2.7$ to 3.6V , $Gnd = 0\text{V}$, $T_A = -40^\circ\text{C}$ to $+85^\circ\text{C}$)

Parameter	Symbol	55ns		Unit
		Min	Max	
Write cycle time	t_{WC}	55	-	ns
Chip select to end of write	t_{CW1}, t_{CW2}	45	-	ns
Address setup time	t_{As}	0	-	ns
Address valid to end of write	t_{AW}	45	-	ns
\overline{UB} , \overline{LB} valid to end of write	t_{BW}	45	-	ns
Write pulse width	t_{WP}	45	-	ns
Write recovery time	t_{WR}	0	-	ns
Write to output high-Z	t_{WHZ}	0	20	ns
Data to write time overlap	t_{DW}	25		ns
Data hold from write time	t_{DH}	0	-	ns
End write to output low-Z	t_{OW}	5		ns

TIMING DIAGRAMS

TIMING WAVEFORM OF READ CYCLE (1) (Address Controlled, $\overline{CS1}=\overline{OE}=V_{IL}$, $CS2=\overline{WE}=V_{IH}$, \overline{UB} or/and $\overline{LB}=V_{IL}$)

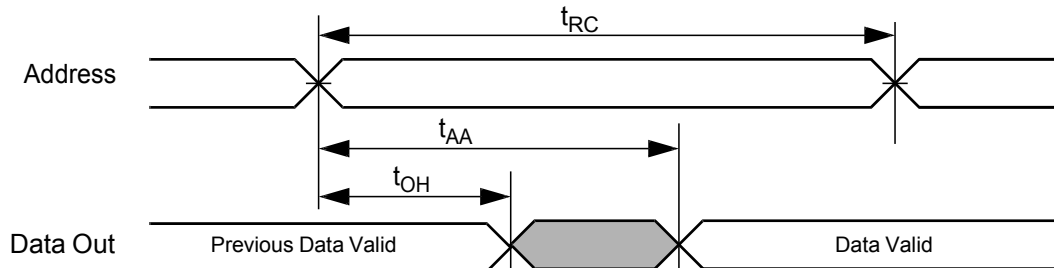

TIMING WAVEFORM OF READ CYCLE (2) ($\overline{WE}=V_{IH}$)

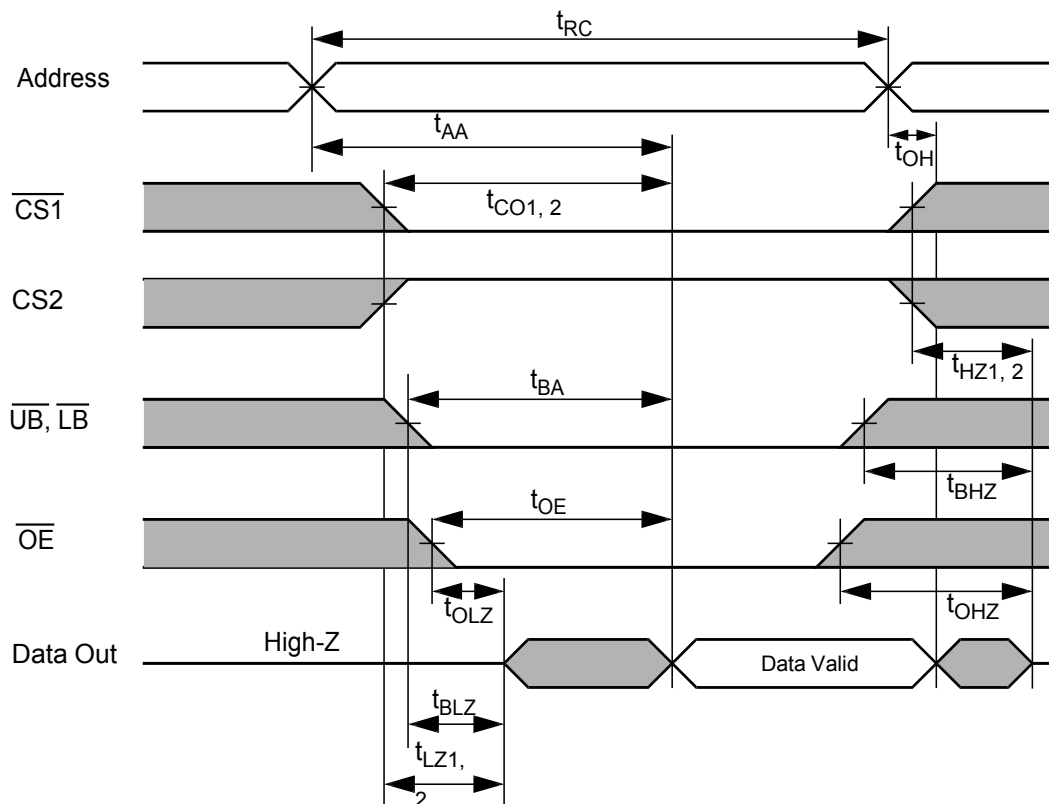

NOTES (READ CYCLE)

- $t_{HZ1,2}$ and t_{OHZ} are defined as the outputs achieve the open circuit conditions and are not referenced to output voltage levels.
- At any given temperature and voltage condition, $t_{HZ1,2}(\text{Max.})$ is less than $t_{LZ1,2}(\text{Min.})$ both for a given device and from device to device interconnection.

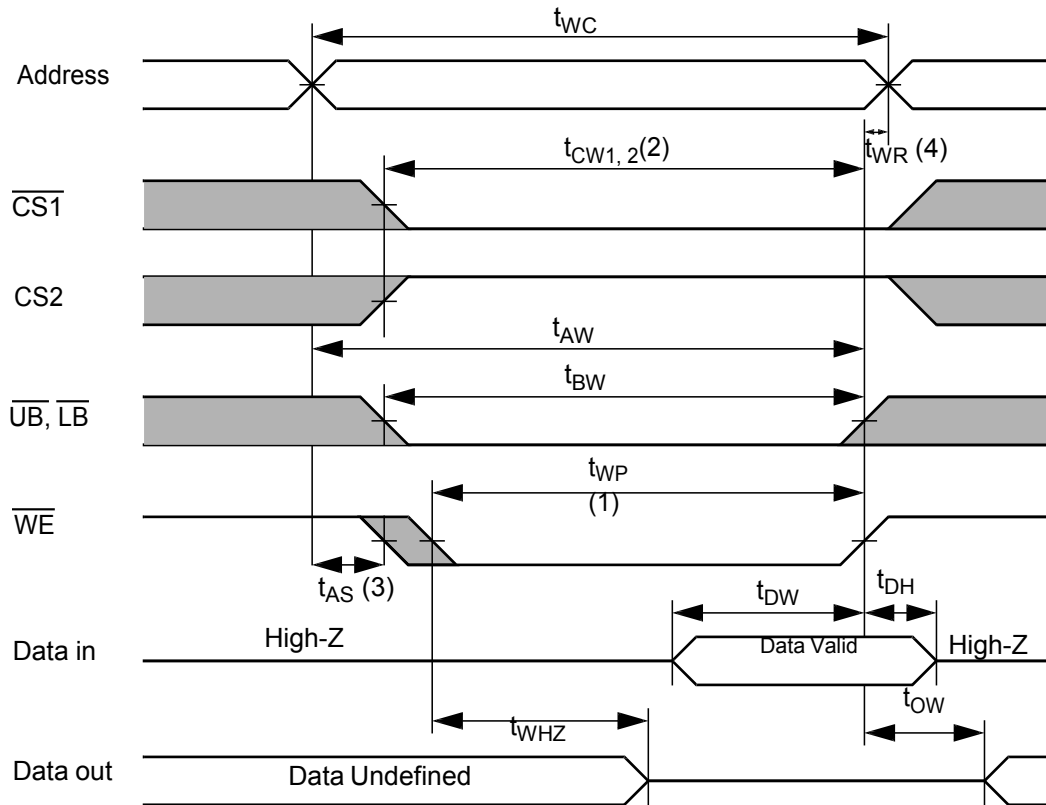
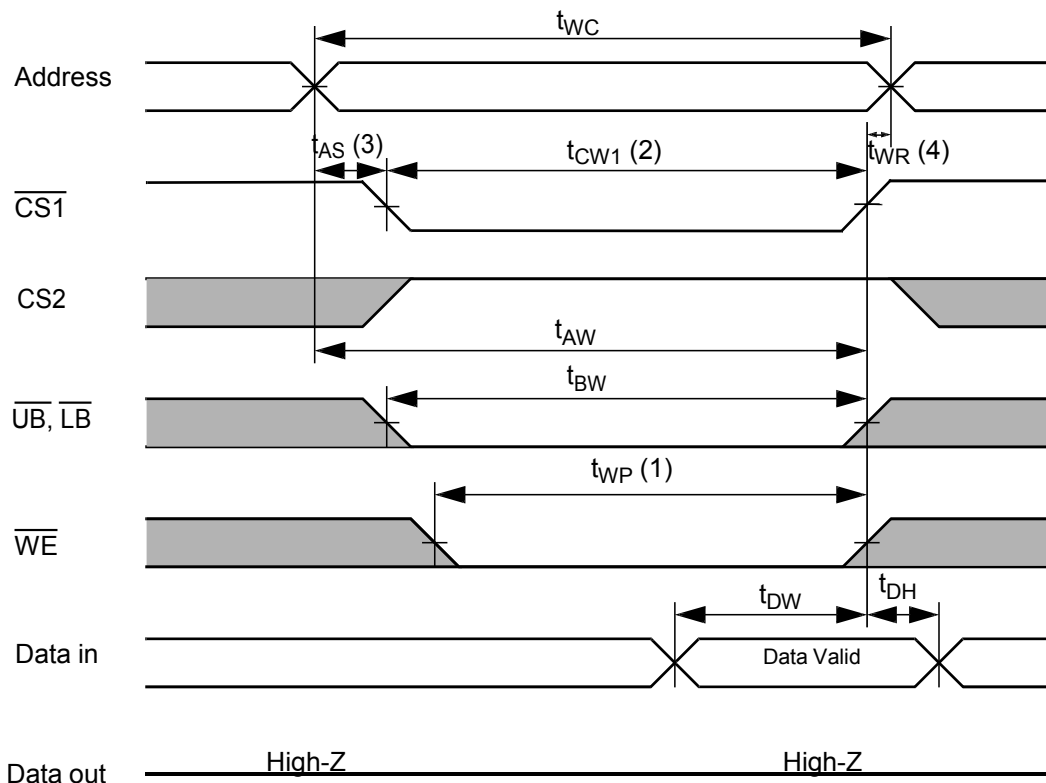
TIMING WAVEFORM OF WRITE CYCLE (1) (\overline{WE} Controlled)

TIMING WAVEFORM OF WRITE CYCLE (2) ($\overline{CS1}$ Controlled)

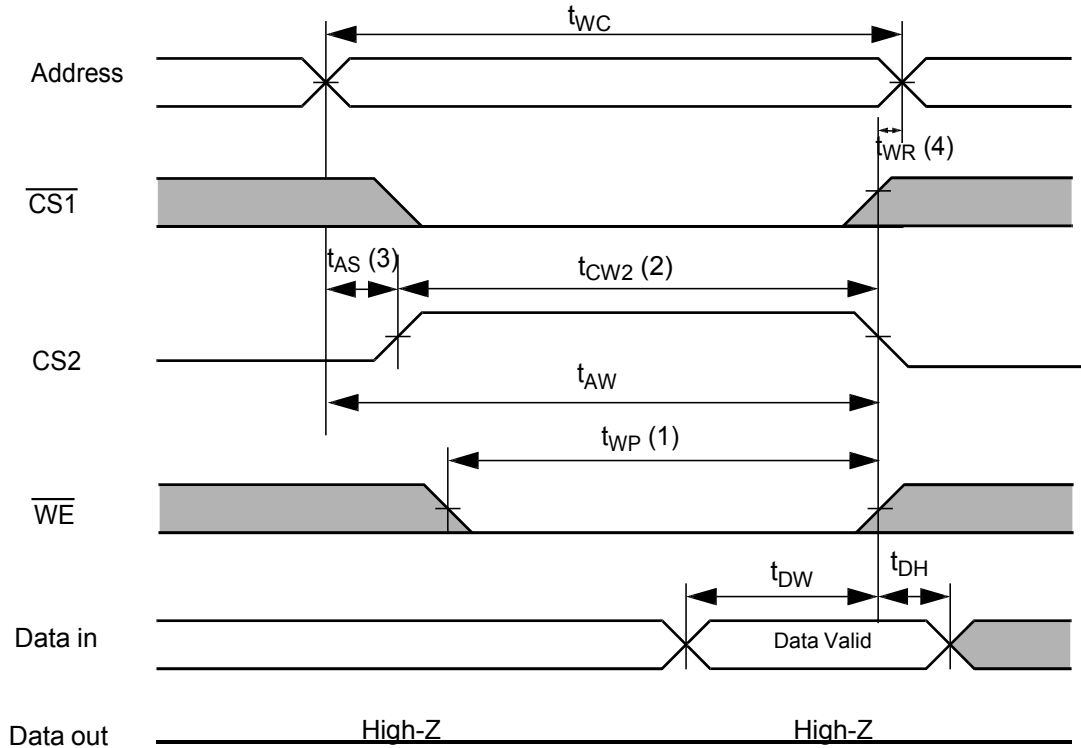
TIMING WAVEFORM OF WRITE CYCLE (3) (CS2 Controlled)

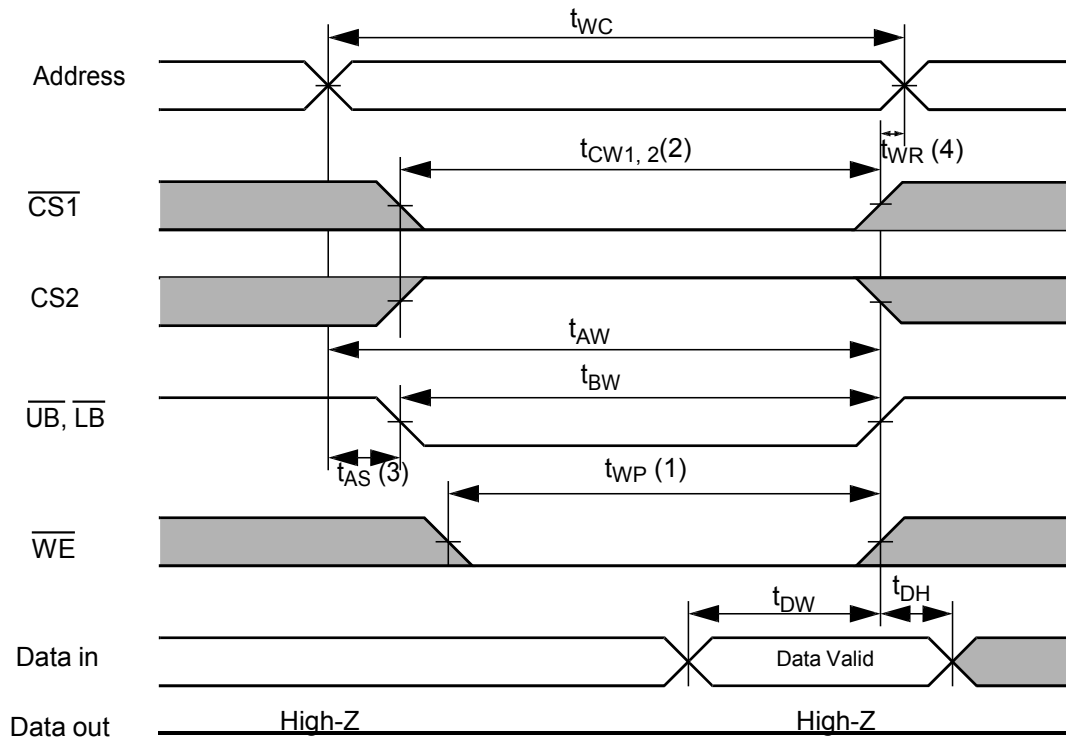

TIMING WAVEFORM OF WRITE CYCLE (4) (\overline{UB} , \overline{LB} Controlled)



NOTES (WRITE CYCLE)

1. A write occurs during the overlap (t_{WP}) of low $\overline{CS1}$, a high $CS2$ and low \overline{WE} . A write begins at the latest transition among $\overline{CS1}$ goes low, $CS2$ goes high and \overline{WE} goes low. A write ends at the earliest transition among $\overline{CS1}$ goes high, $CS2$ goes low and \overline{WE} goes high. The t_{WP} is measured from the beginning of write to the end of write.
2. t_{CW} is measured from the $\overline{CS1}$ going low or $CS2$ going high to end of write.
3. t_{AS} is measured from the address valid to the beginning of write.
4. t_{WR} is measured from the end of write to the address change. t_{WR} applied in case a write ends as $\overline{CS1}$ or \overline{WE} going high or $CS2$ going low.

DATA RETENTION CHARACTERISTICS

Parameter	Symbol	Test Condition	Min	Typ	Max	Unit
V _{CC} for Data Retention	V _{DR}	I _{SB1} Test Condition (Chip Disabled) ¹⁾	1.5	-	3.6	V
Data Retention Current	I _{DR}	V _{CC} =1.5V, I _{SB1} Test Condition (Chip Disabled) ¹⁾	-	-	4	μA
Chip Deselect to Data Retention Time	t _{SDR}	See data retention wave form	0	-	-	ns
Operation Recovery Time	t _{RDR}		t _{RC}	-	-	

NOTES

 1. See the I_{SB1} measurement condition of datasheet page 5.

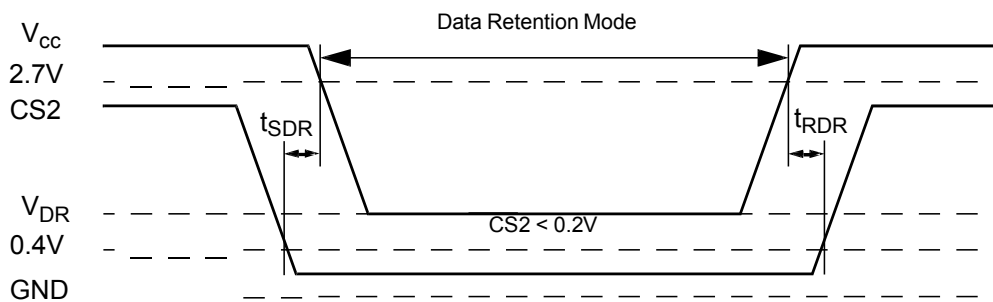
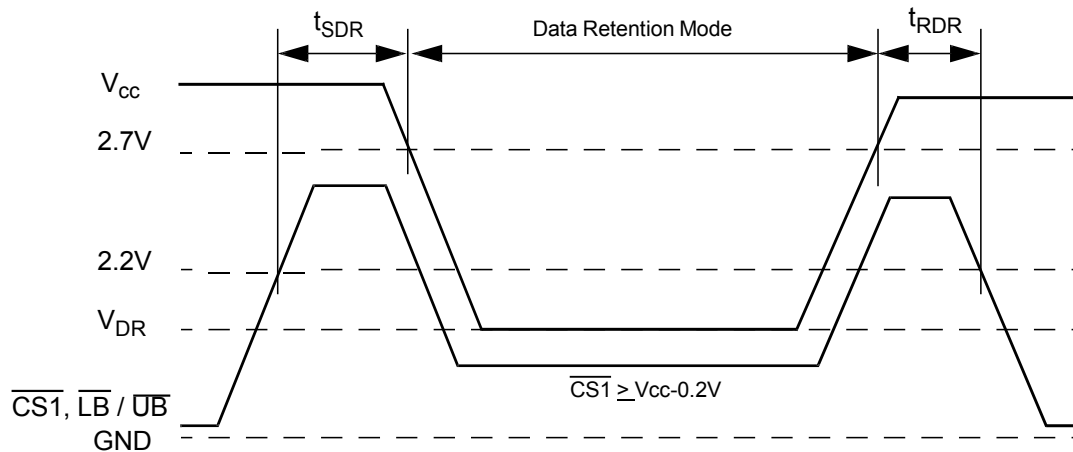
DATA RETENTION WAVE FORM

PACKAGE DIMENSION

48 Ball Fine Pitch BGA (0.75mm ball pitch)

Unit: millimeters

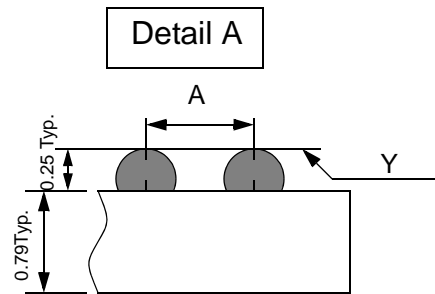
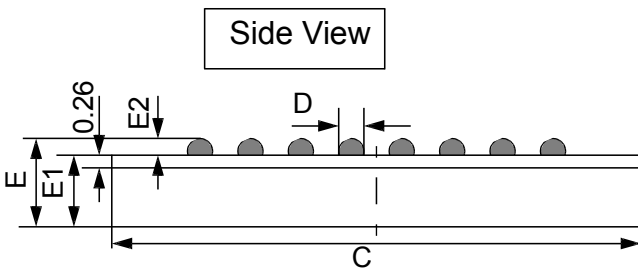
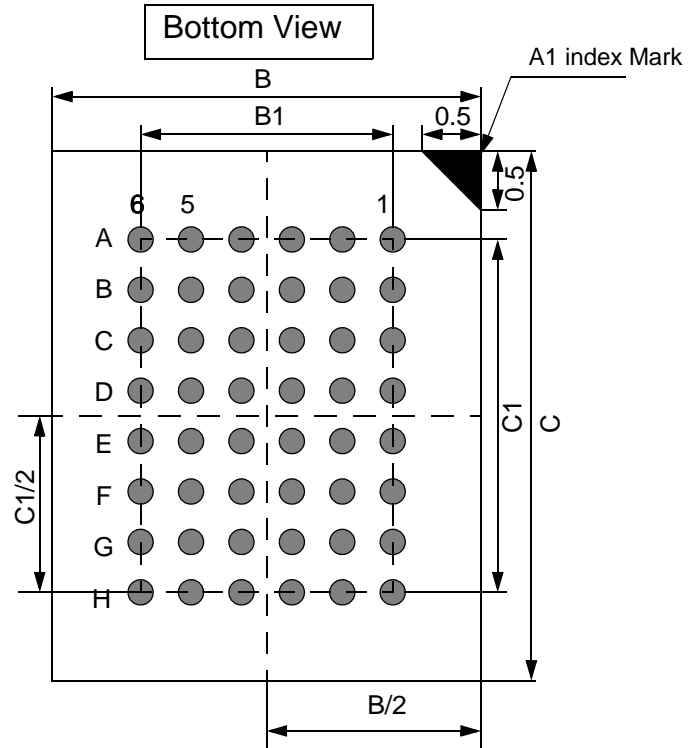
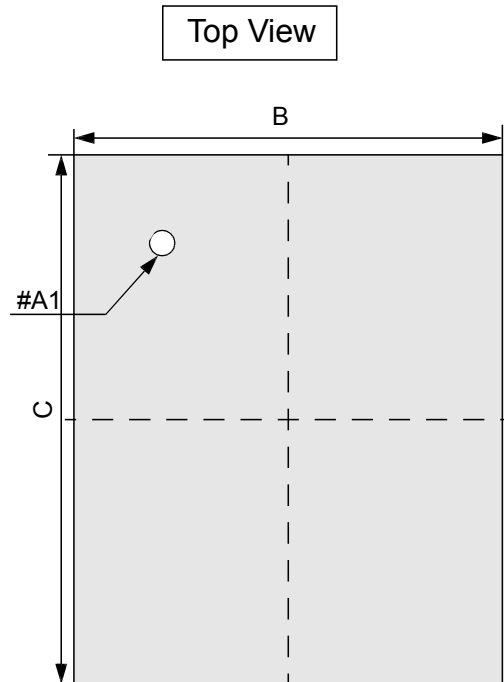

	Min	Typ	Max
A	-	0.75	-
B	7.95	8.00	8.05
B1	-	3.75	-
C	9.95	10.00	10.05
C1	-	5.25	-
D	0.30	0.35	0.40
E	-	-	1.00
E1	-	-	0.70
E2	0.20	0.25	0.30
Y	-	-	0.08

NOTES.

1. Bump counts: 48(8row x 6column)
2. Bump pitch : (x,y)=(0.75x0.75) (typ.)
3. All tolerance is +/-0.050 unless otherwise specified.
4. Typ : Typical
5. Y is coplanarity : 0.08(Max)

ORDERING INFORMATION

Alliance Part no	Organization	Vcc Range	Package	Operating Temp	Speed ns
AS6C8016A-55BIN - Tray	512 x 16	2.7V – 3.6V	48 Ball Fine Pitch FPBGA (0.75mm ball pitch)	-40°C~85°C	55
AS6C8016A-55BINTR – Tape & Reel	512 x 16	2.7V – 3.6V	48 Ball Fine Pitch FPBGA (0.75mm ball pitch)	-40°C~85°C	55

PART NUMBERING SYSTEM

AS6C	8016	A	-55	B	I	N
LOW POWER SRAM PREFIX	DEVICE NUMBER 80 = 8M 16 = by 16	Device revision or sub-contract Wafer build supplier identification	Access Time	B = 48 Ball Fine Pitch FPBGA (0.75mm ball pitch)	Temperature range: I = Industrial (-40°C to 85°C)	N = Lead Free ROHS Compliant Part

Alliance Memory Inc. 551 Taylor Way, San Carlos, CA 94070

TEL: (650) 610-6800

FAX: (650) 620-9211

Alliance Memory Inc. reserves the right to change products or specification without notice.