



**AMSR1-Z Series**



Picture coming soon

SIP3

Aimtec's AMSR1-Z is a 1A Switching Regulator which is designed to be a plug and play alternative to the traditional 78xx series three-terminal linear regulators. The series features an ultra-wide input voltage range of 4.6-36V, 1.5mA ultra- low no load input current, continuous short-circuit protection, low ripple noise (max.: up to 50mV) and much more.

The new 1A series has an operating temperature from -40°C to +100°C, meets EN62368 standard (Pending) and delivers efficiencies up to 96%, eliminating the need for a heat sink and cutting additional design space and installation costs. This series is suitable for use in applications such as industrial controls, IoT, medical, mining, railway and other related industries.

**Features**



- Input Voltage up to 36V
- Operating Temp: -40 °C to +100 °C
- Ultra-low no load input current: 1.5mA typ.
- Low ripple & noise, up to 50mV max.
- Continuous short circuit protection
- Efficiency up to 96%

**Summary**

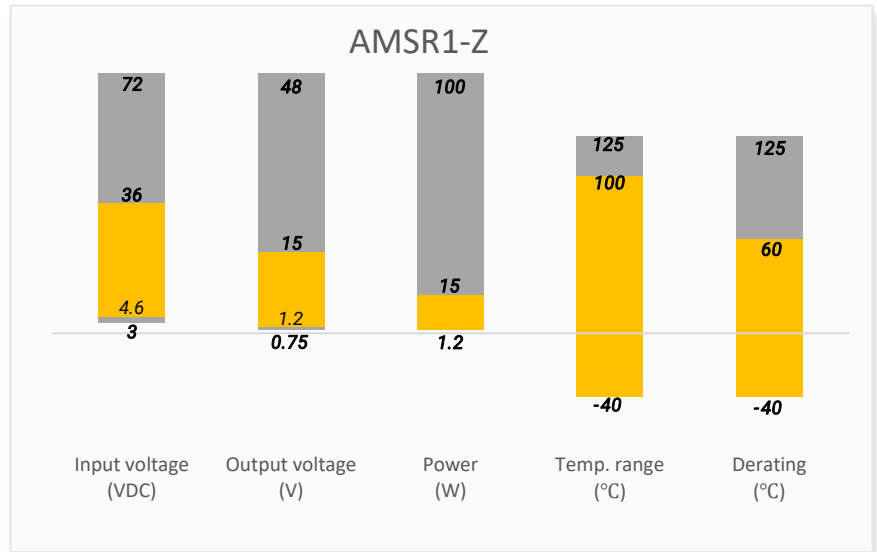

**Training**

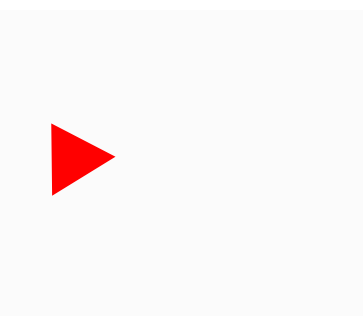

Product Training Video  
(click to open)

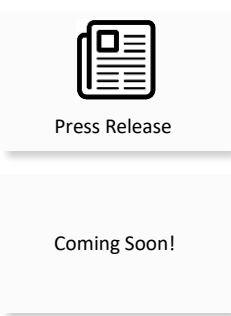

Application Notes

**Applications**



IoT



Industrial



Railway

## Models & Specifications



### Single Output

Model	Input Voltage (VDC)	Output Voltage (VDC)	Full Load Input Current (mA)		Output Current max (A)	Maximum Capacitive Load (μF)	Efficiency (%) Typ.	
			Vin (Min)	Vin (Max)			Vin (Min) @ Full load	Vin (Max) @ Full load
AMSR1-241.2Z	24 (4.6 - 36)	1.2	300	47	1	680	87	72
AMSR1-241.5Z	24 (4.6 - 36)	1.5	367	55	1	680	89	76
AMSR1-241.8Z	24 (4.6 - 36)	1.8	433	64	1	680	90.5	79
AMSR1-242.5Z	24 (4.6 - 36)	2.5	588	84	1	680	92.5	83
AMSR1-243.3Z	24 (4.75 - 36)	3.3	740	106	1	680	94	86.5
AMSR1-2405Z	24 (6.5 - 36)	5	806	156	1	680	95.5	89.5
AMSR1-246.5Z	24 (9 - 36)	6.5	765	201	1	680	94.5	90
AMSR1-2409Z	24 (12 - 36)	9	786	272	1	470	95.5	92
AMSR1-2412Z	24 (15 - 36)	12	843	359	1	470	95	93
AMSR1-2415Z	24 (18 - 36)	15	869	444	1	330	96	94

### Input Specification

Parameters	Conditions	Typical	Maximum	Units
Voltage range	24VDC Nominal		36	VDC
No-load input current		1.5		mA
Input reflected ripple current*		35		mAp-p
Absolute maximum rating	<100mS		40	VDC
Start-up time	Nominal input, constant resistive load	5		mS
Input filter	Capacitors			

\* Measured with a simulated source inductance of 12μH and a source capacitor 10μF at nominal input under full load.

### Output Specification

Parameters	Conditions	Typical	Maximum	Units
Voltage accuracy			±2	%
Line regulation	Vout ≤ 2.5V models		±0.5	%
	others		±0.3	%
Load regulation	10-100% load, Vout ≤ 2.5V models		±0.8	%
	10-100% load, Vout ≥ 3.3V models		±0.6	%
	10-100% load, Vout ≥ 9.0V models		±0.5	%
	0-100% load, Vout ≤ 2.5V models		±1.5	%
	0-100% load, Vout ≥ 3.3V models		±0.8	%
	0-100% load, Vout ≥ 9.0V models		±0.5	%
Short circuit protection	Continuous, Auto recovery			
Ripple & Noise*	Vout ≤ 6.5V models		50	mV pk-pk
	others		75	mV pk-pk
Transient recovery time	Nominal input, 25% load step change	250		μS
Transient response deviation	Nominal input, 25% load step change		±3	%

\*20MHz bandwidth with a 0.1uF CC.

General Specifications				
Parameters	Conditions	Typical	Maximum	Units
Switching frequency		410		KHz
Operating temperature	See derating graph	-40 to +100		°C
Storage temperature		-55 to +125		°C
Maximum case temperature			105	°C
Temperature coefficient		±0.02		%/°C
Lead temperature	1.5mm away from case, maximum duration 10s		260	°C
Cooling	Free air convection (30-65LFM)			
Humidity	Non-condensing		95	% RH
Case material	Plastic (flammability to UL 94V-0)			
Weight		2.3		g
Dimensions (L x W x H)	0.46 x 0.30 x 0.40 inches (11.68 x 7.50 x 10.16 mm)			
MTBF	> 3 500 000 hrs (MIL-HDBK-217F, t=+25°C)			

All specifications in this datasheet are measured at an ambient temperature of 25°C, humidity<75%, nominal input voltage and rated output load unless otherwise specified.

Safety Specifications		
Parameters		
Standards	Design to meet IEC/EN 60950-1 and 62368-1	
	EMI - Conducted and radiated emission	EN55032, CLASS B with recommended circuit
	Electrostatic Discharge Immunity	IEC 61000-4-2, Criteria A
	RF, Electromagnetic Field Immunity	IEC 61000-4-3, Criteria A
	Electrical Fast Transient/Burst Immunity	IEC 61000-4-4, Criteria A
	Surge Immunity	IEC 61000-4-5, Criteria A with recommended circuit
	RF, Conducted Disturbance Immunity	IEC 61000-4-6, Criteria A with recommended circuit
	Power Frequency Magnetic Field Immunity	IEC 61000-4-8, Criteria A

## Derating

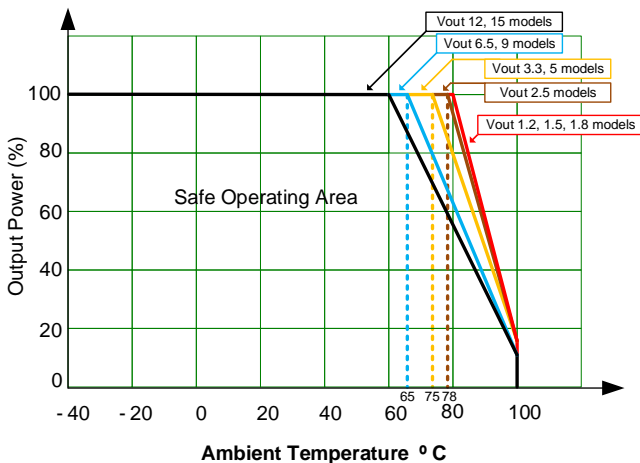

Input Reflected Ripple Current

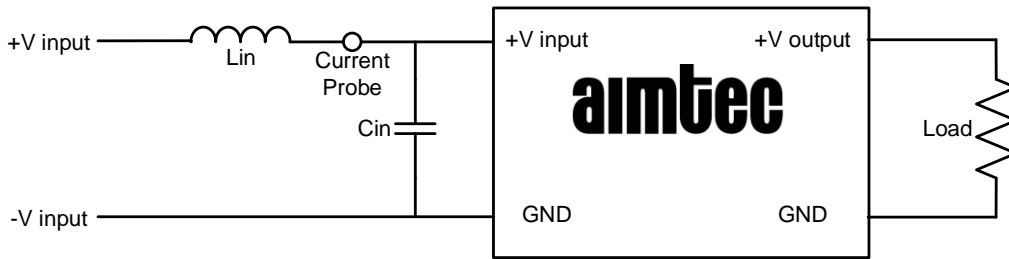

$L_{in}$ : 12 $\mu$ H /  $C_{in}$ : 10 $\mu$ F, ESR<1.0 $\Omega$  at 100KHz

EMI Application Circuit (Conducted Emissions)

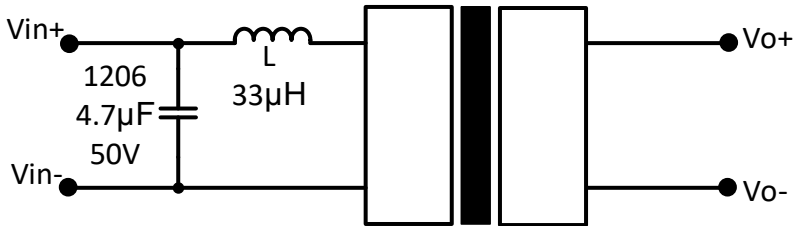

EFT & Surge Application Circuit

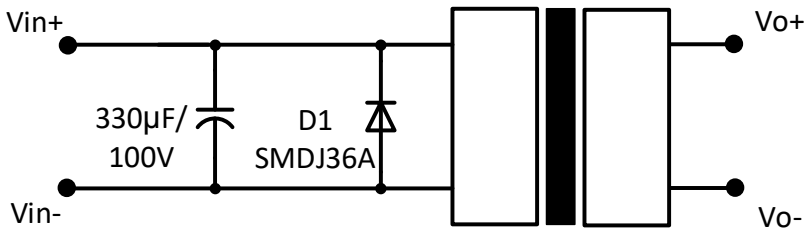

Dimensions

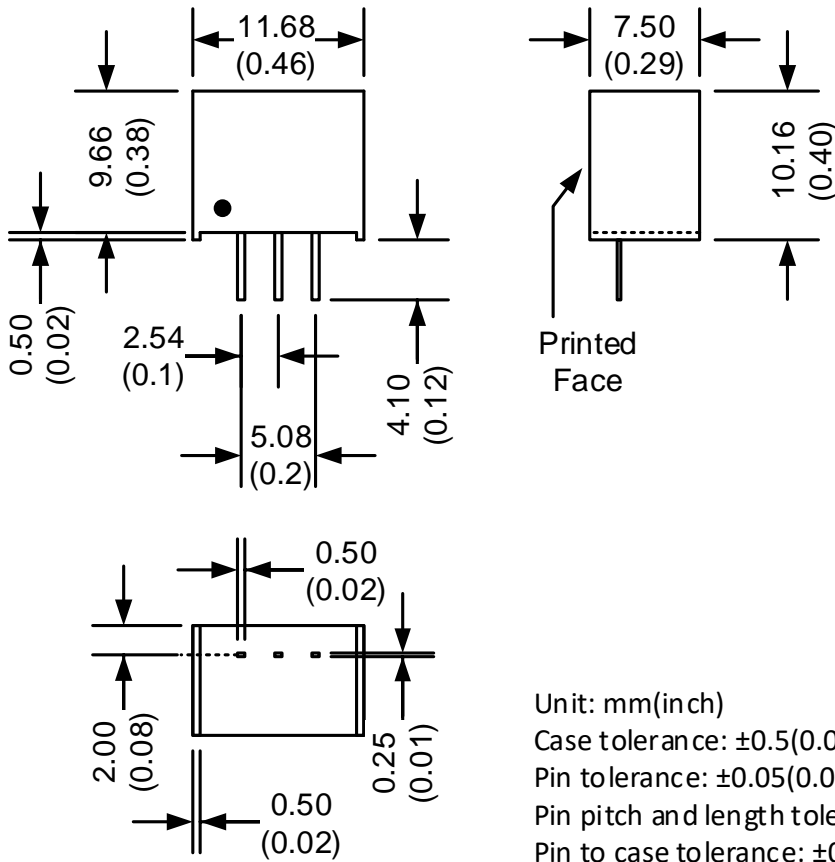

Pin Output Specifications	
Pin	Positive output
1	+V Input
2	GND
3	+V Output

Unit: mm(inch)  
Case tolerance:  $\pm 0.5(0.02)$   
Pin tolerance:  $\pm 0.05(0.002)$   
Pin pitch and length tolerance:  $\pm 0.35(0.014)$   
Pin to case tolerance:  $\pm 0.5(0.02)$

**NOTE: 1.** Datasheets are updated as needed and as such, specifications are subject to change without notice. Once printed or downloaded, datasheets are no longer controlled by Aimtec; refer to [www.aimtec.com](http://www.aimtec.com) for the most current product specifications. **2.** Product labels shown, including safety agency certifications on labels, may vary based on the date manufactured. **3.** Mechanical drawings and specifications are for reference only. **4.** All specifications are measured at an ambient temperature of 25°C, humidity<75%, nominal input voltage and at rated output load unless otherwise specified. **5.** Aimtec may not have conducted destructive testing or chemical analysis on all internal components and chemicals at the time of publishing this document. CAS numbers and other limited information are considered proprietary and may not be available for release. **6.** This product is not designed for use in critical life support systems, equipment used in hazardous environments, nuclear control systems or other such applications which necessitate specific safety and regulatory standards other the ones listed in this datasheet. **7.** Warranty is in accordance with Aimtec's standard Terms of Sale available at [www.aimtec.com](http://www.aimtec.com).