

REV.	ECR/ECN No.	DESCRIPTION	DRAWN/DATE	CHECKED/DATE	APPROVED/DATE
B	/	Update the drawing	May 2020-08-11	Rain 2020-08-11	Xiaohong.zhu 2020-08-11
C	/	Add specification	May 2021-06-28	SH.Chen 2021-06-28	Rain.Han 2021-06-28

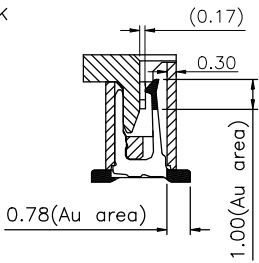
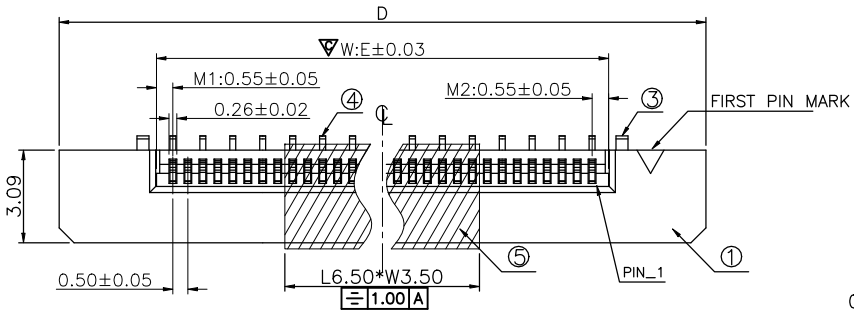

NO.	COMPONENTS	MATERIALS	SPECIFICATION:FINISH/COLOR	QTY.
1	SLIDER	GLASS FILLED PA9T, UL94V-0	BLACK	1
2	HOUSING	GLASS FILLED LCP, UL94V-0	NATURAL	1
3	ANCHOR-PLATE	BRASS, T=0.40mm	SURFACE PLATING:2~5 um Sn UNDER PLATING:1~3 um Ni	1
4	CONTACT	PHOSPHOR BRONZE, T=0.20mm	SURFACE PLATING:SEE "NOTE" UNDER PLATING:1~3 um Ni	N
5	MYLAR	T=0.10mm 耐高温	YELLOW	1

NOTE:
 1.ALL MATERIAL MUST BE COMPLY WITH SS-00259/RoHS.
 2."▽" MARK is Significant characteristic dimension
 3."▽" MARK is Critical characteristic dimension
 4.PART NO. LEGEND:
 F3*-1A**1-110**

14:WITH MYLAR(A TYPE)
 36:WITHOUT MYLAR(A TYPE)
 1A:LCP NATURAL

NO. OF POSITIONS
 7H:PHOSPHOR BRONZE 0.05um MIN Au(Au Area)
 7A:PHOSPHOR BRONZE MATTER TIN
 AF:PHOSPHOR BRONZE 0.75um MIN Au(Au Area)

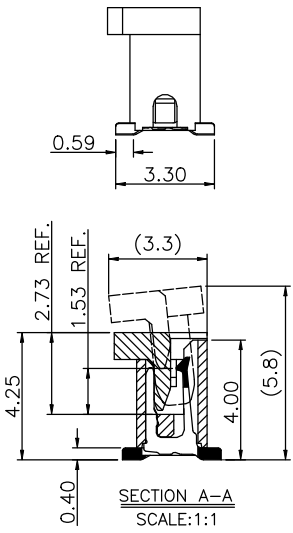
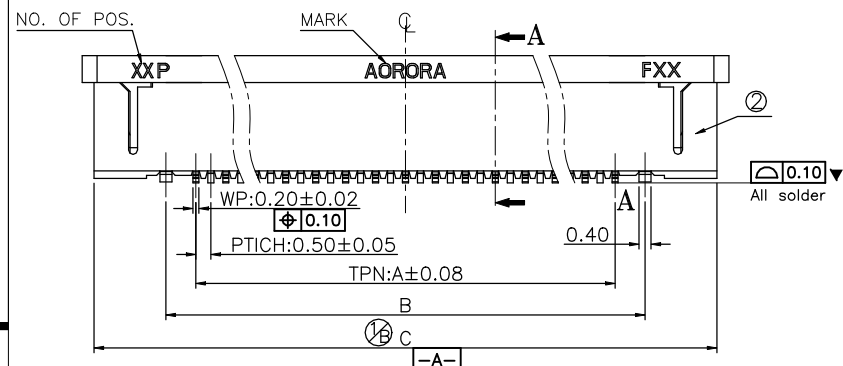

DIMENSION LIST: (Symbol)

NO. OF POS.	A	B	C	D	E	NO. OF POS.	A	B	C	D	E
30	14.50	16.50	21.30	22.10	15.60	45	22.00	24.00	28.80	29.60	23.10
31	15.00	17.00	21.80	22.60	16.10	46	22.50	24.50	29.30	30.10	23.60
32	15.50	17.50	22.30	23.10	16.60	47	23.00	25.00	29.80	30.60	24.10
33	16.00	18.00	22.80	23.60	17.10	48	23.50	25.50	30.30	31.10	24.60
34	16.50	18.50	23.30	24.10	17.60	49	24.00	26.00	30.80	31.60	25.10
35	17.00	19.00	23.80	24.60	18.10	50	24.50	26.50	31.30	32.10	25.60
36	17.50	19.50	24.30	25.10	18.60	51	25.00	27.00	31.80	32.60	26.10
37	18.00	20.00	24.80	25.60	19.10	52	25.50	27.50	32.30	33.10	26.60
38	18.50	20.50	25.30	26.10	19.60	53	26.00	28.00	32.80	33.60	27.10
39	19.00	21.00	25.80	26.60	20.10	54	26.50	28.50	33.30	34.10	27.60
40	19.50	21.50	26.30	27.10	20.60	55	27.00	29.00	33.80	34.60	28.10
41	20.00	22.00	26.80	27.60	21.10	56	27.50	29.50	34.30	35.10	28.60
42	20.50	22.50	27.30	28.10	21.60	57	28.00	30.00	34.80	35.60	29.10
43	21.00	23.00	27.80	28.60	22.10	58	28.50	30.50	35.30	36.10	29.60
44	21.50	23.50	28.30	29.10	22.60	59	29.00	31.00	35.80	36.60	30.10
45	22.00	24.00	28.80	29.60	23.10	60	29.50	31.50	36.30	37.10	30.60

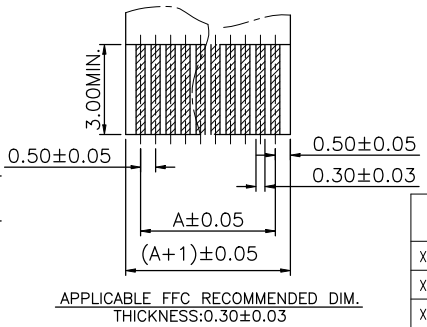
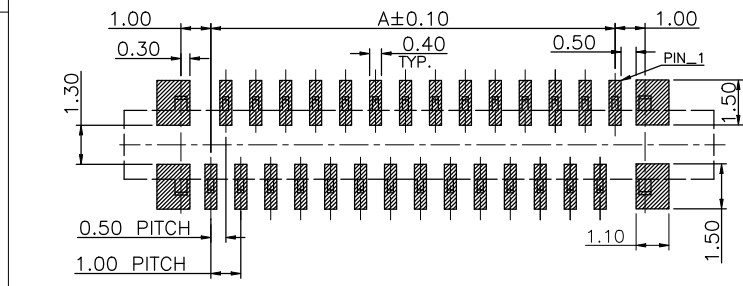
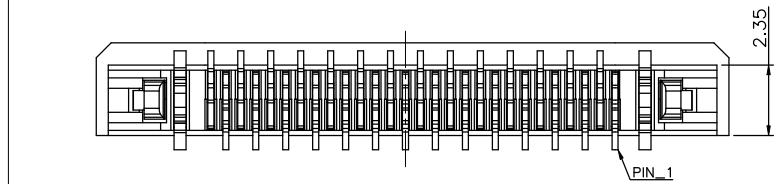

UNLESS OTHERWISE SPECIFIED TOLERANCES		ANGLE OF PROJECTION	
X.	±0.30	X.	± 5°
X.X	±0.25	X.X	± 4°
X.XX	±0.20	X.XX	± 3°
X.XXX	±0.15	X.XXX	± 2°
LINEAR DIMS		ANGLES DIMS	

Amphenol AORORA
 Amphenol Aorora Technology (Huizhou) Co.,Ltd

Customer Drw

DRAWN DATE: May 2021-06-28
 CHECKED DATE: SH.Chen 2021-06-28
 APPROVED DATE: Rain.Han 2021-06-28

TITLE: Assembly Drawing For 0.50mm pitch 30-60PIN VERTICAL SMT A TYPE,SLIDER SERIES

DWG NO.: A-S0107

MATERIAL: SEE NOTES
 FINISHED: SEE NOTES

SCALE: 4:1
 UNIT: mm
 SHEET: 1 OF 2

REV. C

This document is the property of and embodies CONFIDENTIAL and PROPRIETARY information of AOR. No part of the information shown on this document may be used in any way or disclosed to others without the written consent of AOR. © 2019 AOR

1. PACKING INTO REEL:

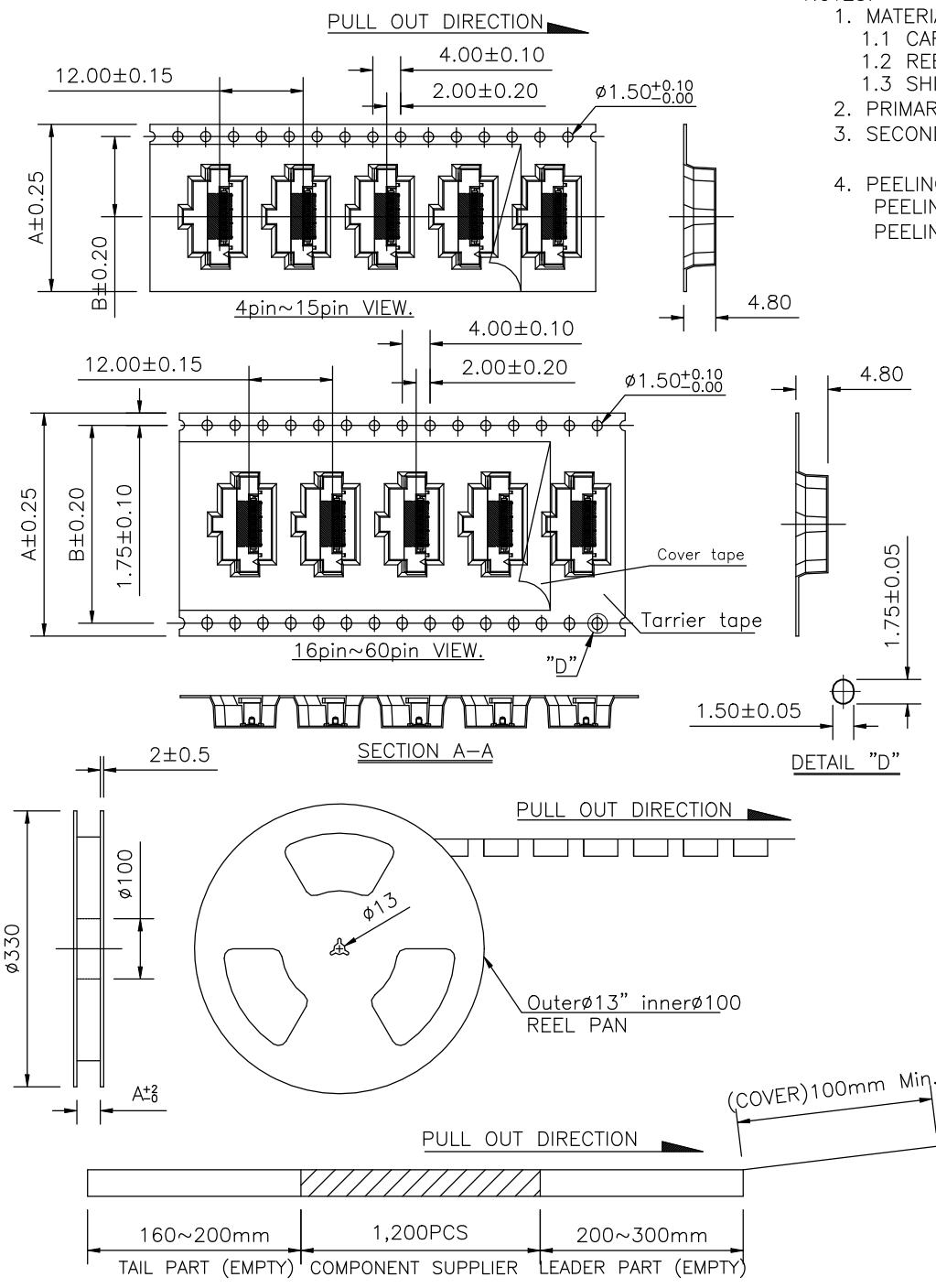

NOTES:

- MATERIAL:
 - CARRY TAPE:HIPS,T=0.35mm,CLEAR
 - REEL:HIPS,BLUE.
 - SHIM:PE,CLEAR.
- PRIMARY PACKING:1,200PCS/REEL.
- SECONDARY PACKING:"N"REELS/CARTON
("TOTAL"=N*1200/CARTON).
- PEELING RESISTANCE: 0.1N~0.7N(10~70gf);
PEELING ANGLE: 165°~180°;
PEELING SPEED: 300mm/minutes.

5. LIST

DIM	NO.	4~15	16~25	26~50	51~60
A		24.00	32.00	44.00	56.00
B		16.40	28.40	40.40	52.40
N		10	8	6	5
TOTAL(PCS)		12000	9600	7200	6000

2:PACKING INTO OUTER BOX

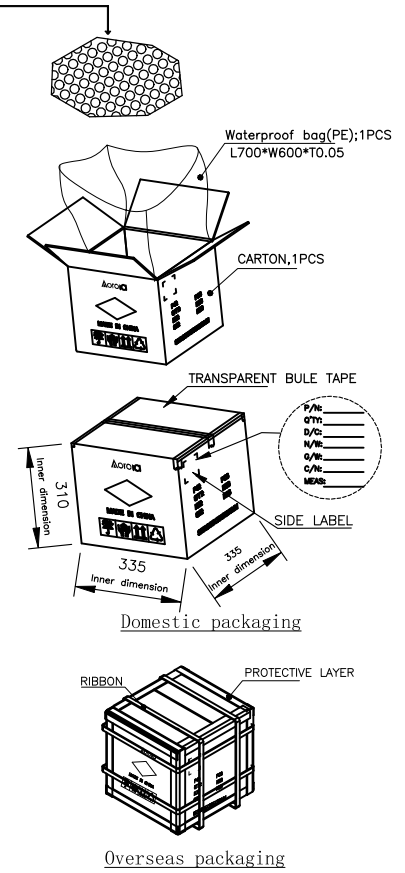
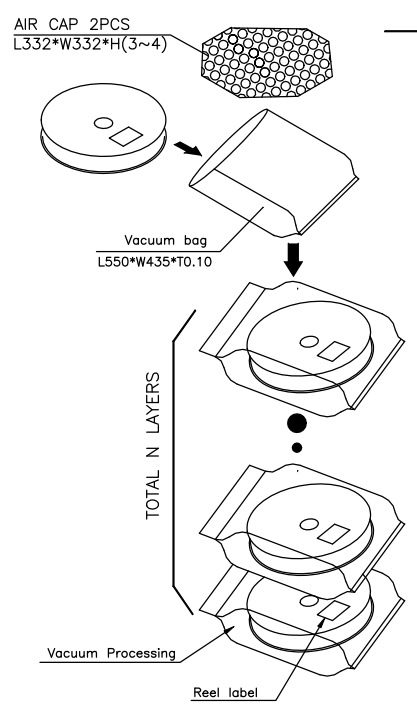

UNLESS OTHERWISE SPECIFIED TOLERANCES			ANGLE OF PROJECTION	
X.	±0.30	X. '	± 5'	
X.X	±0.25	X.X '	± 4'	
X.XX	±0.20	X.XX '	± 3'	Customer Drw
X.XXX	±0.15	X.XXX '	± 2'	
LINEAR DIMS		ANGLES DIMS		DOC TYPE
DWG NO.: A-S0107		DESIGN DATE		May 2014-12-25
MATERIAL		CHECKED DATE		Rain.Han 2014-12-25
FINISHED		APPROVED DATE		Leo.Liu 2014-12-25

Amphenol AORORA
Amphenol Aorora Technology (Huizhou) Co.,Ltd

TITLE: Assembly Drawing For 0.50mm pitch 30-60PIN VERTICAL SMT A TYPE,SLIDER SERIES

SIZE: A4 PART NUMBER: F314-1A**1-110**
F336-1A**1-110**

SCALE: 1:1 UNIT: mm SHEET 2 OF 2

REV. C

This document is the property of and embodies CONFIDENTIAL and PROPRIETARY information of AOR. No part of the information shown on this document may be used in any way or disclosed to others without the written consent of AOR. © 2019 AOR