

PRODUCT NO.  
10120513-002LF

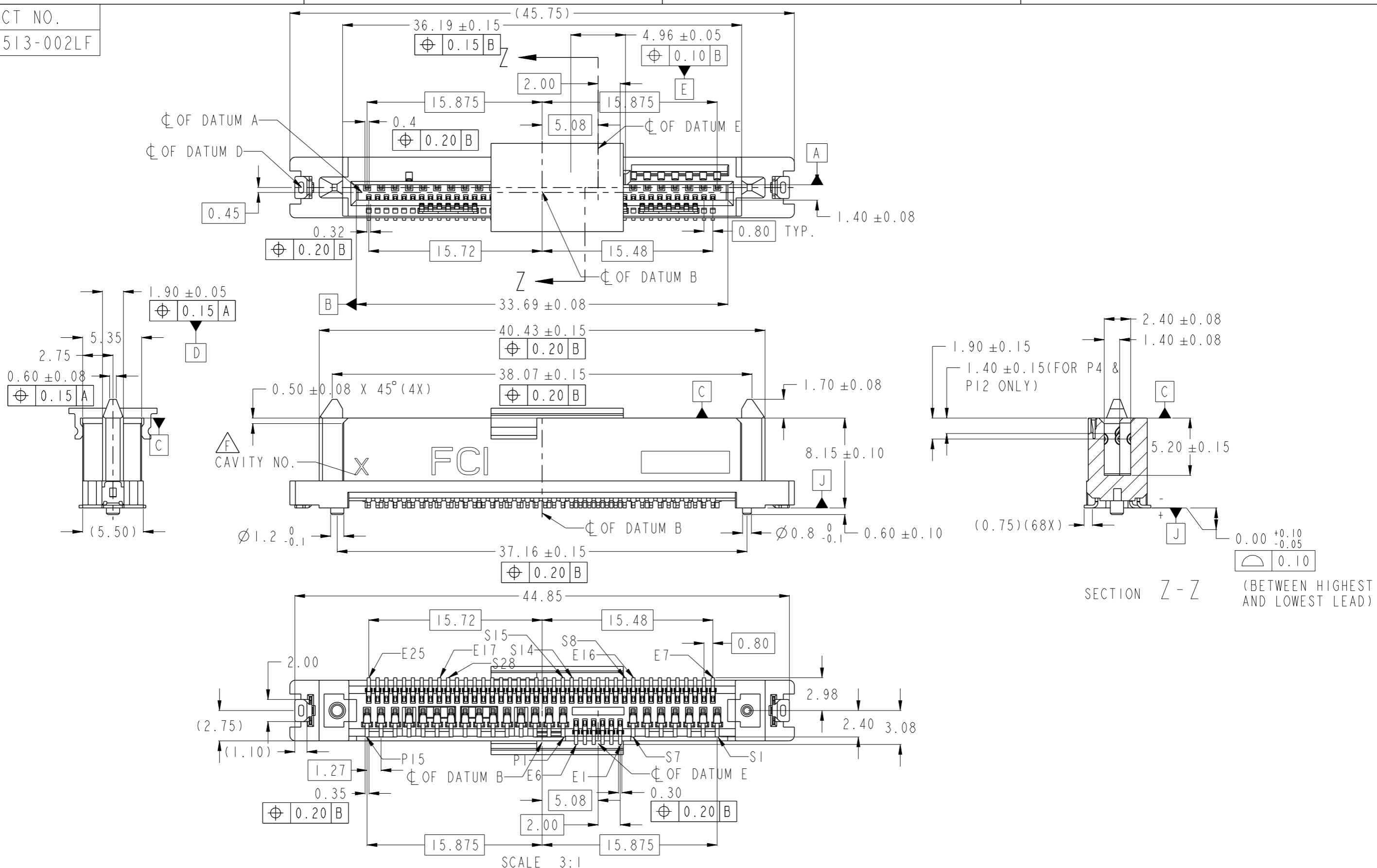

Amphenol  
FCi

© 2020 Amphenol Corporation

spec ref	-	dr	Koon-Poh Tay	2013/11/07	projection	MM	size	A3	scale	1:1											
tolerance std	TOLERANCES UNLESS OTHERWISE SPECIFIED	eng	Jeffrey Lim	2021/03/05			ecn no	ELX-S-40252-1													
surface	<table border="1"> <tr> <td>linear</td> <td>0.X</td> <td>±0.3</td> </tr> <tr> <td></td> <td>0.XX</td> <td>±0.20</td> </tr> <tr> <td></td> <td>0.XXX</td> <td>±</td> </tr> <tr> <td>angular</td> <td>0°</td> <td>±2°</td> </tr> </table>	linear	0.X	±0.3				0.XX	±0.20		0.XXX	±	angular	0°	±2°	chr	-	product family	-	rel level	Released
linear	0.X	±0.3																			
	0.XX	±0.20																			
	0.XXX	±																			
angular	0°	±2°																			
		appr	Koon-Poh Tay	2021/03/08	<p><b>Amphenol FCI</b></p> <p>SAS/PCIe RECEPTACLE</p> <p>VERTICAL SMT</p>		dwg no	10120513		rev	F										
		amphenol-icc.com		cat. no.	-		Product - Customer Drw		sheet 1 of 2												

Creo File:ELX-WC-A3C.REV F.2020-12-21

PRODUCT NO.	HOLD DOWN	PLATING	PICK UP CAP	PACKAGING
10120513-002LF	2 PCS	NOTE 2	NO	TRAY
10120513-002CLF			YES	
10120513-002TRLF			NO	TAPE & REEL
10120513-002C-TRLF			YES	
10120513-002CETRLF				

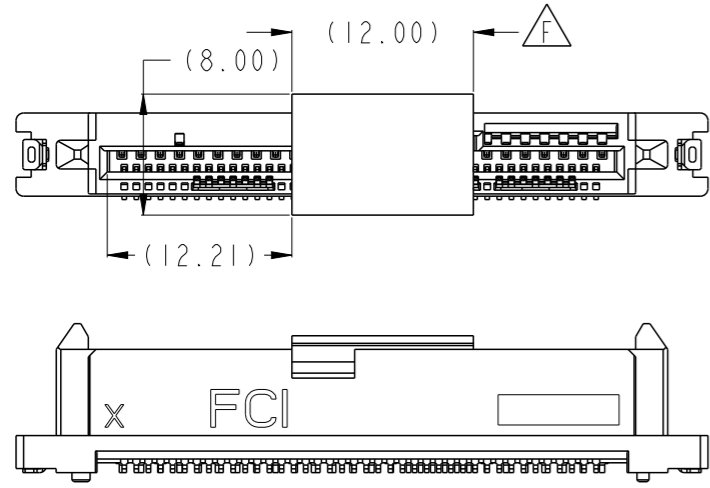

WITH PICKUP CAP ATTACHED  
SCALE 2:1

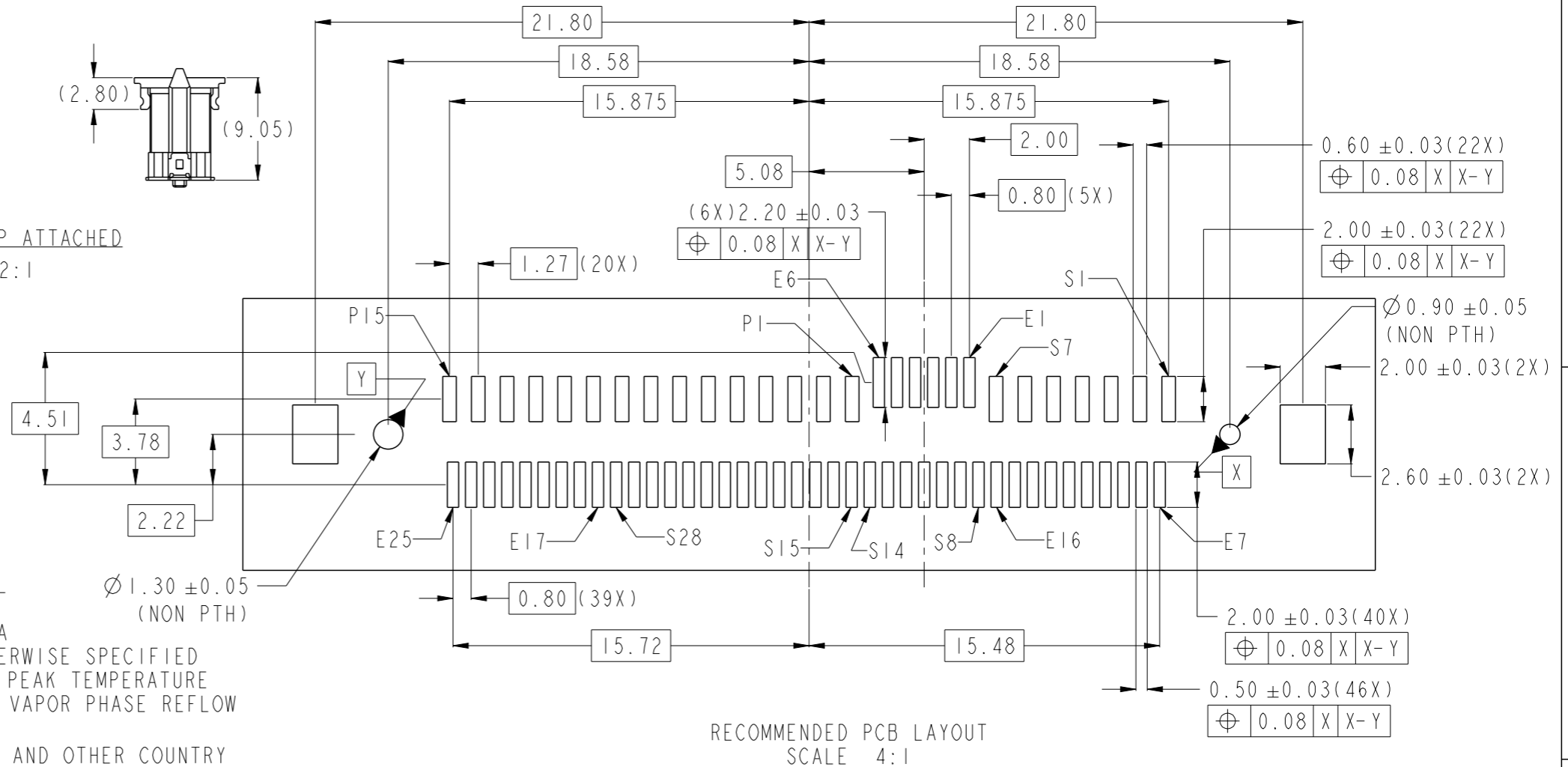

RECOMMENDED PCB LAYOUT  
SCALE 4:1

- NOTES:
- MATERIAL:
    - HOUSING HIGH TEMP THERMOPLASTIC, UL 94V-0  
COLOUR: BLACK
    - TERMINAL: COPPER ALLOY
    - HOLD DOWN: COPPER ALLOY
  - FINISH:
    - TERMINAL: 30u" Au PLATING (CONTACT POINT)  
OVER 50u" NICKEL
    - SOLDER TAIL: 100u" MIN Sn OVER 50u" NICKEL
    - HOLD DOWN: 100u" MIN Sn OVER 50u" NICKEL
  - PER SFF REV 2.2, EXCEPT 0.8mm PITCH BUMP AREA
  - THE STANDARD PACKAGING IS IN TRAY UNLESS OTHERWISE SPECIFIED
  - THE HOUSING WILL WITHSTAND EXPOSURE TO 260°C PEAK TEMPERATURE FOR 10 SECONDS IN A CONVECTION, INFRA-RED OR VAPOR PHASE REFLOW OVEN.
  - THIS PRODUCT MEETS EUROPEAN UNION DIRECTIVES AND OTHER COUNTRY REGULATIONS AS DESCRIBED IN GS-47-0004.
  - PART NUMBER ENDING IN "LF" MEANS FOR LEAD FREE IDENTIFICATION.
  - THIS PRODUCT COMPLIES WITH U.2/SFF-8639 SPECIFICATION
  - PRODUCT SPEC.: GS-12-1169
  - PACKAGING SPEC.: GS-14-966(TAPE & REEL); GS-14-841(TRAY)
  - A SYMBOL WILL BE NEXT TO ANY DIMENSION, VIEW, OR NOTE WHICH HAS BEEN MODIFIED WITH THE CURRENT DRAWING REVISION

spec ref	-	dr	Koon-Poh Tay	2013/11/07	projection	MM	size	A3	scale	1:1
tolerance std	TOLERANCES UNLESS OTHERWISE SPECIFIED	eng	Jeffrey Lim	2021/03/05		← →	ecn no	ELX-S-40252-1	rel level	Released
-		chr	-	-						
surface	linear	appr	Koon-Poh Tay	2021/03/08	product family		-		dwg no	10120513
-	angular	Amphenol FCI		SAS/PCIe RECEPTACLE		-		rev	F	
-	0.X ± 0.3	amphenol-icc.com		VERTICAL SMT		-		Product - Customer Drw		sheet 2 of 2
-	0.XX ± 0.20	cat. no.		-		-		STATUS:Released		Printed: Mar 08, 2021
-	0.XXX ± -	-		-		-		-		-
-	0° ± 2°	-		-		-		-		-