

RECOMMENDED PCB LAYOUT
GENERAL TOLERANCE ±0.05

NOTES:

- MATERIAL:
 - HOUSING: THERMOPLASTIC, HIGH TEMP., UL94V-0;
 - CONTACT: COPPER ALLOY
 - FITTING NAIL: COPPER ALLOY
- FINISH:
 - CONTACT:
 - 50u"MIN NICKEL UNDERPLATING OVERALL.
 - GOLD FLASH PLATING(1~3u") OVERALL.
 - FITTING NAIL:
 - 50u"MIN NICKEL UNDERPLATING OVERALL.
 - GOLD FLASH PLATING(1~3u") OVERALL.
- REFLOW SOLDER CAPABLE TO 260° C PER ACES SPEC.
- SPEC. PLS. REFER TO PS-50021-xxxxx-xxx
- PACKAGE PLS. REFER TO 88386-xxxx-TRP
- PART NUMBER
50028-XXX X X-XXX

No Of CKT

PACKING
7:TAPE & REEL WITH COVER
8:TUBE WITH COVER

PLATING
1:GOLD FLASH OVER ALL

XXX	Housing Color	Halogen Free
001	Black	HF

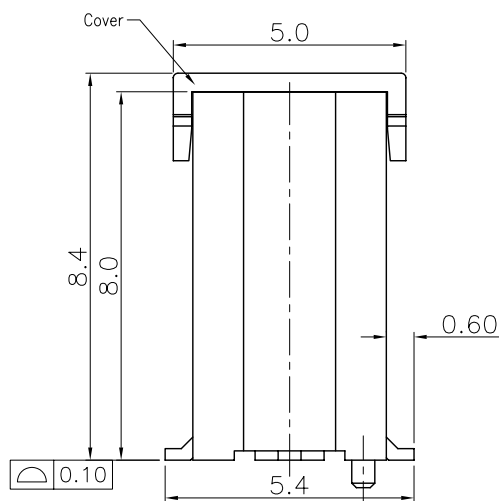
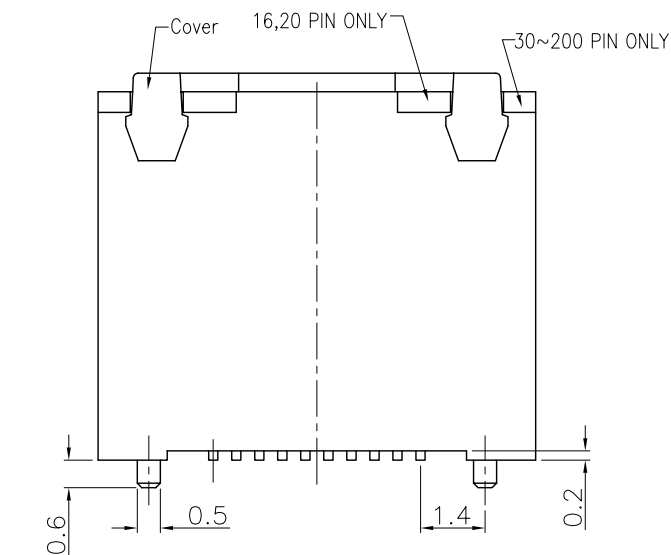

CKT	DIM A	DIM B	DIM C
16	3.5	5.5	8.5
20	4.5	6.5	9.5
30	7.0	9.0	12.0
40	9.5	11.5	14.5
50	12.0	14.0	17.0
60	14.5	16.5	19.5
70	17.0	19.0	22.0
80	19.5	21.5	24.5
100	24.5	26.5	29.5
120	29.5	31.5	34.5
160	39.5	41.5	44.5
180	44.5	46.5	49.5
200	49.5	51.5	54.5

0	NEW DRAWING	08/10/10	Even
REV	REVISION DESCRIPTION	DATE	申請人 SIGNATURE

一般公差 TOLERANCES X .±0.5 .XX ±0.15 .X ±0.25 .XXX ±0.1 ANGLES ±2°		宏致電子股份有限公司 Aces Electronic Co.,Ltd.	
檢驗尺寸標示 SYMBOLS ○ ⊕ INDICATE CLASSIFICATION DIMENSION ⊕ MARK IS CRITICAL DIM. ⊕ MARK IS MAJOR DIM.		品名 (TITLE) 0.5mm BTB D/R CONN. SMT S/T TYPE(WITH COVER) 圖號 (DWG.NO) 50028-XXXXX-XXX	
表面處理 (FINISH)		製圖 (DR) Even 08/10/10 審核 (CHKD) WGCH 核准 (APPD) Jason.C	
比例 (SCALE) 5:1 單位 (UNITS) mm		張數 (SHEET) 1 OF 1 SIZE A4 REV 0	