

**BATTERY PROTECTION IC
FOR 3-SERIAL-CELL PACK**www.ablicinc.com

© ABLIC Inc., 1997-2013

Rev.5.0_02

The S-8233C Series is a series of lithium-ion rechargeable battery protection ICs incorporating high-accuracy voltage detection circuits and delay circuits.

The S-8233C series includes the function to measure the status of battery pack. It is suitable for a 3-serial-cell lithium-ion rechargeable battery pack.

■ Features

- (1) Internal high-accuracy voltage detection circuit
 - Overcharge detection voltage 3.80 ± 0.05 V to 4.40 ± 0.05 V
5 mV - step
 - Overcharge release voltage 3.45 ± 0.10 V to 4.40 ± 0.10 V
5 mV - step

(The overcharge release voltage can be selected within the range where a difference from overcharge detection voltage is 0 to 0.35 V at 50 mV - Step)
 - Overdischarge detection voltage 2.00 ± 0.08 V to 2.80 ± 0.08 V
50 mV - step
 - Overdischarge release voltage 2.00 ± 0.10 V to 4.00 ± 0.10 V
50 mV - step

(The overdischarge release voltage can be selected within the range where a difference from overdischarge detection voltage is 0 to 1.2 V at 50 mV - Step)
 - Overcurrent detection voltage 1 0.15 ± 0.015 V to 0.50 ± 0.05 V
50 mV - step
- (2) High input-voltage device (absolute maximum rating: 26 V)
- (3) Indicates Li-ion battery state.
- (4) Wide operating voltage range: 2 V to 24 V
- (5) The delay time for every detection can be set via an external capacitor.
- (6) Three overcurrent detection levels (protection for short-circuiting)
- (7) Internal charge/discharge prohibition circuit via the control pin
- (8) The function for charging batteries from 0 V is available.
- (9) Low current consumption
 - Operation 50 μA max. (+25 °C)
 - Power-down 0.1 μA max. (+25 °C)
- (10) Lead-free, Sn 100%, halogen-free^{*1}

*1. Refer to "■ Product Name Structure" for details.

■ Applications

- Lithium-ion rechargeable battery packs
- Lithium polymer rechargeable battery packs

■ Package

- 16-Pin TSSOP

■ **Block Diagram**

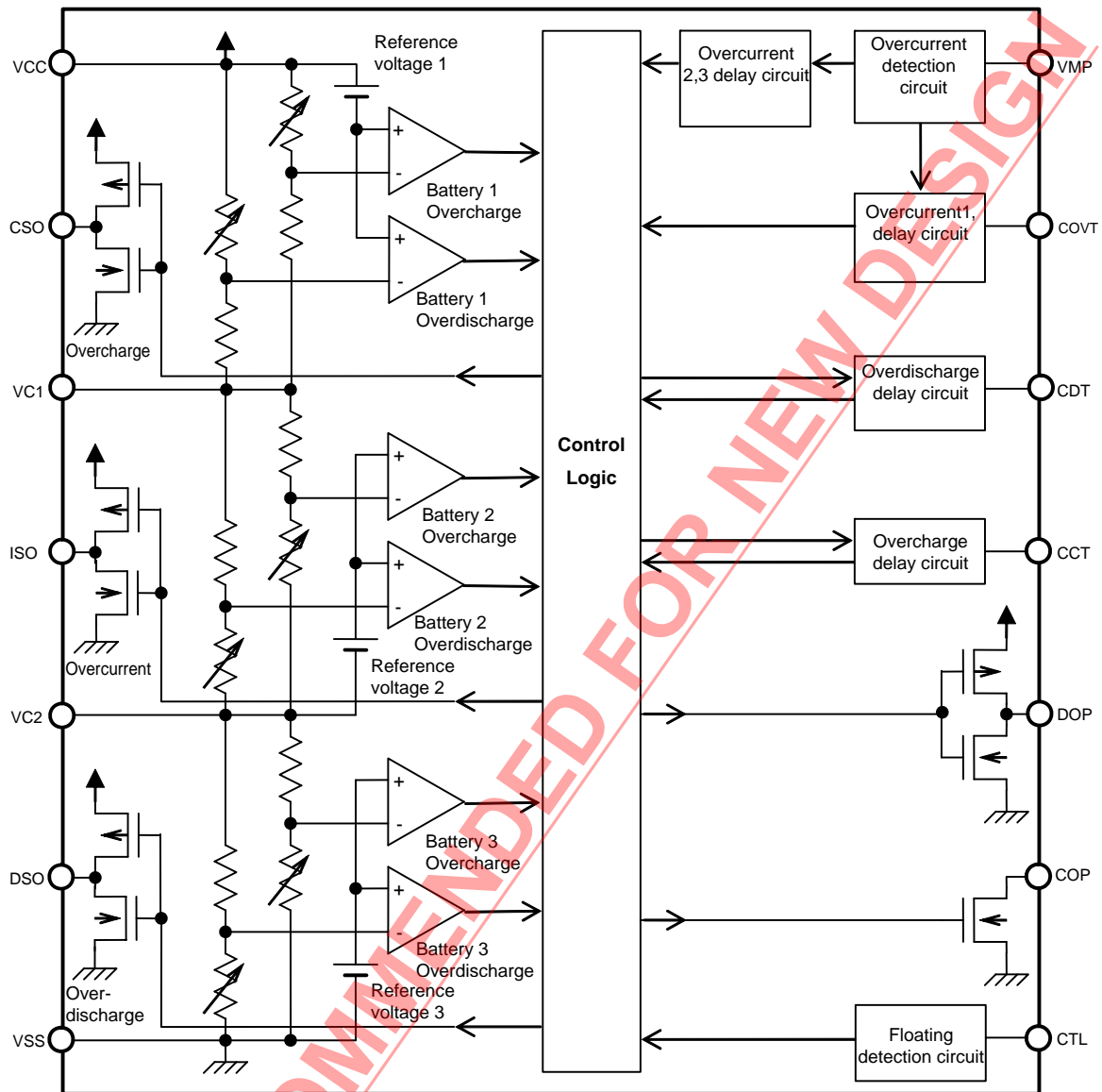

Remark The delay time for overcurrent detection 2 and 3 is fixed by an internal IC circuit. The delay time cannot be changed via an external capacitor.

Figure 1

In the overcharge status, the CSO pin outputs "H".
 In the overdischarge status, the DSO pin outputs "H".
 In the overcurrent status, the ISO pin outputs "H".
 In normal status, the above CSO, DSO, and ISO pins output "L".
 The outputs are CMOS outputs.

■ **Product Name Structure**

1. **Product name**

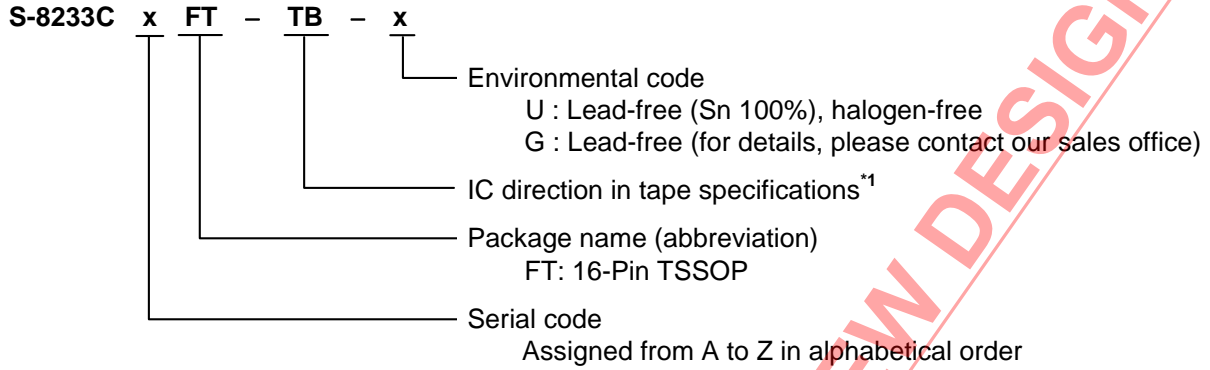

*1. Refer to the tape specifications.

2. **Package**

| Package Name | Drawing Code | | |
|--------------|--------------|--------------|--------------|
| | Package | Tape | Reel |
| 16-Pin TSSOP | FT016-A-P-SD | FT016-A-C-SD | FT016-A-R-SD |

3. **Product name list**

Table1

| Product name / Item | Overcharge detection voltage (V _{CU}) | Overcharge release voltage (V _{CD}) | Overdischarge detection voltage (V _{DD}) | Overdischarge release voltage (V _{DU}) | Overcurrent detection voltage ¹ (V _{IOV1}) | 0 V battery charging function |
|---------------------|---|---|--|--|---|-------------------------------|
| S-8233CAFT-TB-x | 4.250 V | 4.050 V | 2.00 V | 2.30 V | 0.25 V | - |

Remark 1. Please contact our sales office for the products with the detection voltage value other than those specified above.

2. x: G or U
3. Please select products of environmental code = U for Sn 100%, halogen-free products.

■ **Pin Configuration**

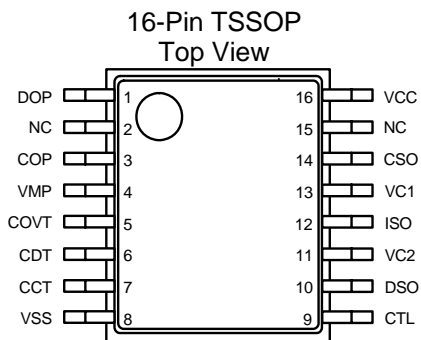

Figure 2

Table2

| Pin No. | Symbol | Description |
|---------|--------|--|
| 1 | DOP | Connects FET gate for discharge control (CMOS output) |
| 2 | NC | Non connect ^{*1} |
| 3 | COP | Connects FET gate for charge control (Nch open-drain output) |
| 4 | VMP | Detects voltage between VCC to VMP (Overcurrent detection pin) |
| 5 | COVT | Connects capacitor for overcurrent detection 1 delay circuit |
| 6 | CDT | Connects capacitor for overdischarge detection delay circuit |
| 7 | CCT | Connects capacitor for overcharge detection delay circuit |
| 8 | VSS | Negative power input, and connects negative voltage for battery 3 |
| 9 | CTL | Charge/discharge control signal input |
| 10 | DSO | Overdischarge status signal output |
| 11 | VC2 | Connects battery 2 negative voltage and battery 3 positive voltage |
| 12 | ISO | Overcurrent status signal output |
| 13 | VC1 | Connects battery 1 negative voltage and battery 2 positive voltage |
| 14 | CSO | Overcharge status signal output |
| 15 | NC | Non connect ^{*1} |
| 16 | VCC | Positive power input and connects battery 1 positive voltage |

*1. The NC pin is electrically open. The NC pin can be connected to VCC or VSS.

NOT RECOMMENDED FOR DESIGN

■ **Absolute Maximum Ratings**

Table3

(Ta = 25°C unless otherwise specified)

| Item | Symbol | Applied Pins | Absolute Maximum Ratings | Unit |
|-----------------------------------|------------------|-------------------------------------|---|------|
| Input voltage between VCC and VSS | V _{DS} | - | V _{SS} -0.3 to V _{SS} +26 | V |
| Input pin voltage | V _{IN} | VC1, VC2, CTL, CCT, CDT, COVT | V _{SS} -0.3 to V _{CC} +0.3 | V |
| VMP pin input voltage | V _{VMP} | VMP | V _{SS} -0.3 to V _{SS} +26 | V |
| CSO,ISO,DSO pin output voltage | V _{OUT} | CSO,ISO,DSO | V _{SS} -0.3 to V _{CC} +0.3 | V |
| DOP pin output voltage | V _{DOP} | DOP | V _{SS} -0.3 to V _{CC} +0.3 | V |
| COP pin output voltage | V _{COP} | COP | V _{SS} -0.3 to V _{VMP} +0.3 | V |
| Power dissipation | P _D | - | 300 (When not mounted on board) | mW |
| | | - | 1100*1 | mW |
| Operating ambient temperature | T _{opr} | - | -20 to +70 | °C |
| Storage temperature | T _{stg} | - | -40 to +125 | °C |

*1. When mounted on board
[Mounted board]

- (1) Board size : 114.3 mm × 76.2 mm × t1.6 mm
- (2) Board name : JEDEC STANDARD51-7

Caution The absolute maximum ratings are rated values exceeding which the product could suffer physical damage. These values must therefore not be exceeded under any conditions.

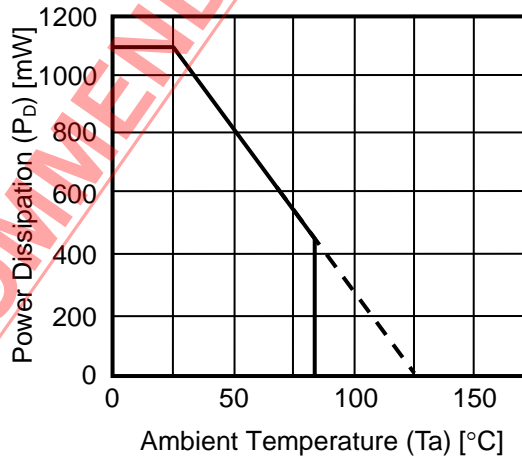

Figure 3 Power Dissipation of Package (When Mounted on Board)

■ **Electrical Characteristics**

Table 4 (1 / 2)

(Ta = 25°C unless otherwise specified)

| Item | Symbol | Condition | Min. | Typ. | Max. | Unit | Test condition | Test circuit |
|--|---------------------|--------------------------------|------------------------|-------------------|------------------------|-------|----------------|--------------|
| Detection voltage | | | | | | | | |
| Overcharge detection voltage 1 | V _{CU1} | 3.80 to 4.40 Adjustment | V _{CU1} -0.05 | V _{CU1} | V _{CU1} +0.05 | V | 1 | 1 |
| Overcharge release voltage 1 | V _{CD1} | 3.45 to 4.40 Adjustment | V _{CD1} -0.10 | V _{CD1} | V _{CD1} +0.10 | V | 1 | 1 |
| Overdischarge detection voltage 1 | V _{DD1} | 2.00 to 2.80 Adjustment | V _{DD1} -0.08 | V _{DD1} | V _{DD1} +0.08 | V | 1 | 1 |
| Overdischarge release voltage 1 | V _{DU1} | 2.00 to 4.00 Adjustment | V _{DU1} -0.10 | V _{DU1} | V _{DU1} +0.10 | V | 1 | 1 |
| Overcharge detection voltage 2 | V _{CU2} | 3.80 to 4.40 Adjustment | V _{CU2} -0.05 | V _{CU2} | V _{CU2} +0.05 | V | 2 | 1 |
| Overcharge release voltage 2 | V _{CD2} | 3.45 to 4.40 Adjustment | V _{CD2} -0.10 | V _{CD2} | V _{CD2} +0.10 | V | 2 | 1 |
| Overdischarge detection voltage 2 | V _{DD2} | 2.00 to 2.80 Adjustment | V _{DD2} -0.08 | V _{DD2} | V _{DD2} +0.08 | V | 2 | 1 |
| Overdischarge release voltage 2 | V _{DU2} | 2.00 to 4.00 Adjustment | V _{DU2} -0.10 | V _{DU2} | V _{DU2} +0.10 | V | 2 | 1 |
| Overcharge detection voltage 3 | V _{CU3} | 3.80 to 4.40 Adjustment | V _{CU3} -0.05 | V _{CU3} | V _{CU3} +0.05 | V | 3 | 1 |
| Overcharge release voltage 3 | V _{CD3} | 3.45 to 4.40 Adjustment | V _{CD3} -0.10 | V _{CD3} | V _{CD3} +0.10 | V | 3 | 1 |
| Overdischarge detection voltage 3 | V _{DD3} | 2.00 to 2.80 Adjustment | V _{DD3} -0.08 | V _{DD3} | V _{DD3} +0.08 | V | 3 | 1 |
| Overdischarge release voltage 3 | V _{DU3} | 2.00 to 4.00 Adjustment | V _{DU3} -0.10 | V _{DU3} | V _{DU3} +0.10 | V | 3 | 1 |
| Overcurrent detection voltage 1 ¹⁾ | V _{IOV1} | 0.15 to 0.50V Adjustment | V _{IOV1} ×0.9 | V _{IOV1} | V _{IOV1} ×1.1 | V | 4 | 2 |
| Overcurrent detection voltage 2 | V _{IOV2} | V _{CC} Reference | 0.54 | 0.6 | 0.66 | V | 4 | 2 |
| Overcurrent detection voltage 3 | V _{IOV3} | V _{SS} Reference | 1.0 | 2.0 | 3.0 | V | 4 | 2 |
| Voltage temperature factor 1 ²⁾ | T _{COE1} | Ta = -20 to 70°C ⁴⁾ | -1.0 | 0 | 1.0 | mV/°C | - | - |
| Voltage temperature factor 2 ³⁾ | T _{COE2} | Ta = -20 to 70°C ⁴⁾ | -0.5 | 0 | 0.5 | mV/°C | - | - |
| Delay time | | | | | | | | |
| Overcharge detection delay time 1 | t _{CU1} | C _{CCT} = 0.47 μF | 0.5 | 1.0 | 1.5 | s | 9 | 6 |
| Overcharge detection delay time 2 | t _{CU2} | C _{CCT} = 0.47 μF | 0.5 | 1.0 | 1.5 | s | 10 | 6 |
| Overcharge detection delay time 3 | t _{CU3} | C _{CCT} = 0.47 μF | 0.5 | 1.0 | 1.5 | s | 11 | 6 |
| Overdischarge detection delay time 1 | t _{DD1} | C _{CDT} = 0.1 μF | 20 | 40 | 60 | ms | 9 | 6 |
| Overdischarge detection delay time 2 | t _{DD2} | C _{CDT} = 0.1 μF | 20 | 40 | 60 | ms | 10 | 6 |
| Overdischarge detection delay time 3 | t _{DD3} | C _{CDT} = 0.1 μF | 20 | 40 | 60 | ms | 11 | 6 |
| Overcurrent detection delay time 1 | t _{IOV1} | C _{COVT} = 0.1 μF | 10 | 20 | 30 | ms | 12 | 7 |
| Overcurrent detection delay time 2 | t _{IOV2} | - | 2 | 4 | 8 | ms | 12 | 7 |
| Overcurrent detection delay time 3 | t _{IOV3} | FET gate capacitor = 2000 pF | 100 | 300 | 550 | μs | 12 | 7 |
| Operating voltage | | | | | | | | |
| Operating voltage between VCC and VSS ⁵⁾ | V _{DSOP} | - | 2.0 | - | 24 | V | - | - |
| Current consumption | | | | | | | | |
| Current consumption (during normal operation) | I _{OPV} | V1 = V2 = V3 = 3.5 V | - | 20 | 50 | μA | 5 | 3 |
| Current consumption for cell 1 | I _{CELL1} | V1 = V2 = V3 = 3.5 V | -300 | 0 | 300 | nA | 5 | 3 |
| Current consumption for cell 2 | I _{CELL2} | V1 = V2 = V3 = 3.5 V | -300 | 0 | 300 | nA | 5 | 3 |
| Current consumption for cell 3 | I _{CELL3} | V1 = V2 = V3 = 3.5 V | -300 | 0 | 300 | nA | 5 | 3 |
| Current consumption at power down | I _{PDN} | V1 = V2 = V3 = 1.5 V | - | - | 0.1 | μA | 5 | 3 |
| Internal resistance with 0V battery charging function type | | | | | | | | |
| Resistance between VCC and VMP | R _{VCM} | V1 = V2 = V3 = 3.5 V | 0.20 | 0.50 | 0.80 | MΩ | 6 | 3 |
| Resistance between VSS and VMP | R _{VSM} | V1 = V2 = V3 = 1.5 V | 0.20 | 0.50 | 0.80 | MΩ | 6 | 3 |
| Internal resistance without 0V battery charging function type | | | | | | | | |
| Resistance between VCC and VMP | R _{VCM} | V1 = V2 = V3 = 3.5 V | 0.40 | 0.90 | 1.40 | MΩ | 6 | 3 |
| Resistance between VSS and VMP | R _{VSM} | V1 = V2 = V3 = 1.5 V | 0.40 | 0.90 | 1.40 | MΩ | 6 | 3 |
| Input voltage | | | | | | | | |
| CTL"H" Input voltage | V _{CTL(H)} | - | V _{CC} × 0.8 | - | - | V | - | - |
| CTL"L" Input voltage | V _{CTL(L)} | - | - | - | V _{CC} × 0.2 | V | - | - |

BATTERY PROTECTION IC FOR 3-SERIAL-CELL PACK
S-8233C Series

Rev.5.0_02

Table 4 (2 / 2)

(Ta = 25 °C unless otherwise specified)

| Item | Symbol | Condition | Min. | Typ. | Max. | Unit | Test condition | Test circuit |
|---|---------------------|---------------------------|----------------------|------|----------------------|------|----------------|--------------|
| Output voltage | | | | | | | | |
| DOP"H" voltage | V _{DO(H)} | I _{OUT} = 10 μA | V _{CC} -0.5 | - | - | V | 7 | 4 |
| DOP"L" voltage | V _{DO(L)} | I _{OUT} = 10 μA | - | - | V _{SS} +0.1 | V | 7 | 4 |
| COP"L" voltage | V _{CO(L)} | I _{OUT} = 10 μA | - | - | V _{SS} +0.1 | V | 8 | 5 |
| COP OFF LEAK current | I _{COL} | V1 = V2 = V3 = 4.5 V | - | - | 100 | nA | 14 | 9 |
| CSO"H" voltage | V _{CSO(H)} | I _{OUT} = 0.1 μA | V _{CC} -0.5 | - | - | V | 13 | 8 |
| CSO"L" voltage | V _{CSO(L)} | I _{OUT} = 10 μA | - | - | V _{SS} +0.1 | V | 13 | 8 |
| ISO"H" voltage | V _{ISO(H)} | I _{OUT} = 0.1 μA | V _{CC} -0.5 | - | - | V | 13 | 8 |
| ISO"L" voltage | V _{ISO(L)} | I _{OUT} = 10 μA | - | - | V _{SS} +0.1 | V | 13 | 8 |
| DSO"H" voltage | V _{DSO(H)} | I _{OUT} = 0.1 μA | V _{CC} -0.5 | - | - | V | 13 | 8 |
| DSO"L" voltage | V _{DSO(L)} | I _{OUT} = 10 μA | - | - | V _{SS} +0.1 | V | 13 | 8 |
| 0 V battery charging function^{*6} | | | | | | | | |
| 0 V charging start voltage | V _{0CHAR} | V1 = V2 = V3 = 0 V | - | - | 1.4 | V | 15 | 10 |

- *1. If overcurrent detection voltage 1 is 0.50 V, both overcurrent detection voltages 1 and 2 are 0.54 V to 0.55 V, but V_{IOV2} > V_{IOV1}.
- *2. Voltage temperature factor 1 indicates overcharge detection voltage, overcharge release voltage, overdischarge detection voltage, and overdischarge release voltage.
- *3. Voltage temperature factor 2 indicates overcurrent detection voltage.
- *4. Since products are not screened at high and low temperature, the specification for this temperature range is guaranteed by design, not tested in production.
- *5. The DOP and COP logic must be established for the operating voltage.
- *6. This spec applies for only 0 V battery charging function available type.

NOT RECOMMENDED FOR NEW DESIGN

■ **Test Circuits**

(1) Test condition 1 Test circuit 1

Set V1, V2, and V3 to 3.5 V under normal status. Increase V1 from 3.5 V gradually. The V1 voltage when COP = 'H' is overcharge detection voltage 1 (V_{CU1}). Decrease V1 gradually. The V1 voltage when COP = 'L' is overcharge release voltage 1 (V_{CD1}). Further decrease V1. The V1 voltage when DOP = 'H' is overdischarge voltage 1 (V_{DD1}). Increase V1 gradually. The V1 voltage when DOP = 'L' is overdischarge release voltage 1 (V_{DU1}).

Remark The voltage change rate is 150 V/s or less.

(2) Test condition 2 Test circuit 1

Set V1, V2, and V3 to 3.5 V under normal status. Increase V2 from 3.5 V gradually. The V2 voltage when COP = 'H' is overcharge detection voltage 2 (V_{CU2}). Decrease V2 gradually. The V2 voltage when COP = 'L' is overcharge release voltage 2 (V_{CD2}). Further decrease V2. The V2 voltage when DOP = 'H' is overdischarge voltage 2 (V_{DD2}). Increase V2 gradually. The V2 voltage when DOP = 'L' is overdischarge release voltage 2 (V_{DU2}).

Remark The voltage change rate is 150 V/s or less.

(3) Test condition 3 Test circuit 1

Set V1, V2, and V3 to 3.5 V under normal status. Increase V3 from 3.5 V gradually. The V3 voltage when COP = 'H' is overcharge detection voltage 3 (V_{CU3}). Decrease V3 gradually. The V3 voltage when COP = 'L' is overcharge release voltage 3 (V_{CD3}). Further decrease V3. The V3 voltage when DOP = 'H' is overdischarge voltage 3 (V_{DD3}). Increase V3 gradually. The V3 voltage when DOP = 'L' is overdischarge release voltage 3 (V_{DU3}).

Remark The voltage change rate is 150 V/s or less.

(4) Test condition 4 Test circuit 2

Set V1, V2, V3 to 3.5 V and V4 to 0 V under normal status. Increase V4 from 0 V gradually. The V4 voltage when DOP = 'H' and COP = 'H' is overcurrent detection voltage 1 (V_{IOV1}).

Set V1, V2, and V3 to 3.5 V and V4 to 0 V under normal status. Fix the COVT pin at V_{SS} , increase V4 from 0 V gradually. The V4 voltage when DOP = 'H' and COP = 'H' is overcurrent detection voltage 2 (V_{IOV2}).

Set V1, V2, and V3 to 3.5 V and V4 to 0 V under normal status. Fix the COVT pin at V_{SS} , increase V4 gradually from 0 V at 400 μ s to 2 ms. The V4 voltage when DOP = 'H' and COP = 'H' is overcurrent detection voltage 3 (V_{IOV3}).

(5) Test condition 5 Test circuit 3

Set S1 to ON, V1, V2, and V3 to 3.5 V, and V4 to 0 V under normal status and measure current consumption. I1 is the normal status current consumption (I_{OPE}), I2, the cell 2 current consumption (I_{CELL2}), and I3, the cell 3 current consumption (I_{CELL3}).

Set S1 to ON, V1, V2, and V3 to 1.5 V, and V4 to 4.5 V under overdischarge status. Current consumption I1 is power-down current consumption (I_{PDN}).

(6) Test condition 6 Test circuit 3

Set S1 to ON, V1, V2, and V3 to 3.5 V, and V4 to 10.5 V under normal status. $V4/I4$ is the internal resistance between VCC and VMP (R_{VCM}).

Set S1 to ON, V1, V2, and V3 to 1.5 V, and V4 to 4.1 V under overdischarge status. $(4.5-V4)/I4$ is the internal resistance between VSS and VMP (R_{VSM}).

(7) Test condition 7 Test circuit 4

Set S1 to ON, S2 to OFF, V1, V2, and V3 to 3.5 V, and V4 to 0 V under normal status. Increase V5 from 0 V gradually. The V5 voltage when $I_5 = 10 \mu\text{A}$ is DOP'L' voltage ($V_{\text{DO(L)}}$).

Set S1 to OFF, S2 to ON, V1, V2, V3 to 3.5 V, and V4 to $V_{\text{IOV2}}+0.1$ V under overcurrent status. Increase V6 from 0 V gradually. The V6 voltage when $I_6 = 10 \mu\text{A}$ is the DOP'H' voltage ($V_{\text{DO(H)}}$).

(8) Test condition 8 Test circuit 5

Set V1, V2, V3 to 3.5 V and V4 to 0 V under normal status. Increase V5 from 0 V gradually. The V5 voltage when $I_5 = 10 \mu\text{A}$ is the COP'L' voltage ($V_{\text{CO(L)}}$).

(9) Test condition 9 Test circuit 6

Set V1, V2, V3 to 3.5 V under normal status. Increase V1 from 3.5 V to 4.5 V immediately (within 10 μs). The time after V1 becomes 4.5 V until COP goes 'H' is the overcharge detection delay time 1 (t_{CU1}).

Set V1, V2, V3 to 3.5 V under normal status. Decrease V1 from 3.5 V to 1.9 V immediately (within 10 μs). The time after V1 becomes 1.9 V until DOP goes 'H' is the overdischarge detection delay time 1 (t_{DD1}).

(10) Test condition 10 Test circuit 6

Set V1, V2, V3 to 3.5 V under normal status. Increase V2 from 3.5 V to 4.5 V immediately (within 10 μs). The time after V2 becomes 4.5 V until COP goes 'H' is the overcharge detection delay time 2 (t_{CU2}).

Set V1, V2, V3 to 3.5 V under normal status. Decrease V2 from 3.5 V to 1.9 V immediately (within 10 μs). The time after V2 becomes 1.9 V until DOP goes 'H' is the overdischarge detection delay time 2 (t_{DD2}).

(11) Test condition 11 Test circuit 6

Set V1, V2, V3 to 3.5 V under normal status. Increase V3 from 3.5 V to 4.5 V immediately (within 10 μs). The time after V3 becomes 4.5 V until COP goes 'H' is the overcharge detection delay time 3 (t_{CU3}).

Set V1, V2, V3 to 3.5 V under normal status. Decrease V3 from 3.5 V to 1.9 V immediately (within 10 μs). The time after V3 becomes 1.9 V until DOP goes 'H' is the overdischarge detection delay time 3 (t_{DD3}).

(12) Test condition 12 Test circuit 7

Set V1, V2, V3 to 3.5 V and S1 to OFF under normal status. Increase V4 from 0 V to 0.55 V immediately (within 10 μs). The time after V4 becomes 0.55 V until DOP goes 'H' is the overcurrent detection delay time 1 (t_{IOV1}).

Set V1, V2, V3 to 3.5 V and S1 to OFF under normal status. Increase V4 from 0 V to 0.75 V immediately (within 10 μs). The time after V4 becomes 0.75 V until DOP goes 'H' is the overcurrent detection delay time 2 (t_{IOV2}).

Set S1 to ON to inhibit overdischarge detection. Set V1, V2, V3 to 4.0 V and increase V4 from 0 V to 6.0 V immediately (within 1 μs) and decrease V1, V2, and V3 to 2.0 V at a time. The time after V4 becomes 6.0 V until DOP goes 'H' is the overcurrent detection delay time 3 (t_{IOV3}).

(13) Test condition 13 Test circuit 8

Set S4 to ON, S1, S2, S3, S5, and S6 to OFF, V1, V2, V3 to 3.5 V, and V4, V6, to 0 V under normal status. Increase V5 from 0 V gradually. The V5 voltage when $I_5 = 10 \mu\text{A}$ is the CSO'L' voltage ($V_{\text{CSO(L)}}$)

Set S5 to ON, S1, S2, S3, S4, and S6 to OFF, V1, V2, and V3 to 3.5 V and V4, V6 to 0 V under normal status. Increase V5 from 0 V gradually. The V5 voltage when $I_5 = 10 \mu\text{A}$ is the ISO'L' voltage ($V_{\text{ISO(L)}}$).

Set S6 to ON, S1, S2, S3, S4, and S5 to OFF, V1, V2, and V3 to 3.5 V and V4, V6 to 0 V under normal status. Increase V5 from 0 V gradually. The V5 voltage when $I_5 = 10 \mu\text{A}$ is the DSO'L' voltage ($V_{\text{DSO(L)}}$).

Set S1 to ON, S2, S3, S4, S5, and S6 to OFF, V1 to 4.5V, V2, and V3 to 3.5 V, V5, and V6 to 0 V under overcharge status. Increase V4 from 0 V gradually. The V4 voltage when $I_4 = 0.1 \mu\text{A}$ is the CSO'H' voltage ($V_{\text{CSO(H)}}$).

Set S2 to ON, S1, S3, S4, S5, and S6 to OFF, V1, V2 and V3 to 3.5 V, V5 to 0 V, V6 to $V_{\text{IOV2}}+0.1\text{V}$ under overcurrent status. Increase V4 from 0 V gradually. The V4 voltage when $I_4 = 0.1 \mu\text{A}$ is the ISO'H' voltage ($V_{\text{ISO(H)}}$).

Set S3 to ON, S1, S2, S4, S5, and S6 to OFF, V1 to 1.9V, V2 and V3 to 3.5 V, V5 and V6 to 0 V under overdischarge status. Increase V4 from 0 V gradually. The V4 voltage when $I_4 = 0.1 \mu\text{A}$ is the DSO'H' voltage ($V_{\text{DSO(H)}}$).

(14) Test condition 14 Test circuit 9

Set V1, V2, and V3 to 4.5 V under overcharge status. The current I_1 flowing to COP pin is COP OFF LEAK current (I_{COL}).

(15) Test condition 15 Test circuit 10

Set V1, V2, and V3 to 0 V, and V8 to 2 V, and decrease V8 gradually. The V8 voltage when COP = 'H' ($V_{\text{SS}} + 0.1 \text{ V}$ or higher) is the 0 V charge start voltage (V_{0CHAR}).

NOT RECOMMENDED FOR NEW DESIGN

**BATTERY PROTECTION IC FOR 3-SERIAL-CELL PACK
S-8233C Series**

Rev.5.0_02

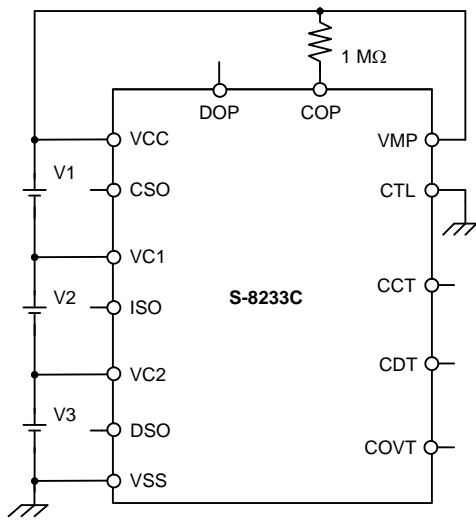

Test circuit 1

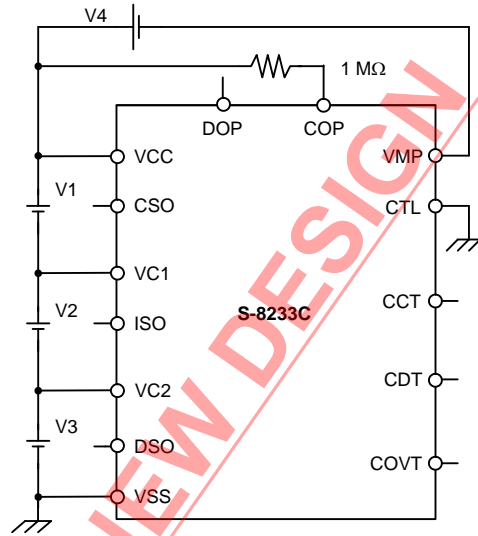

Test circuit 2

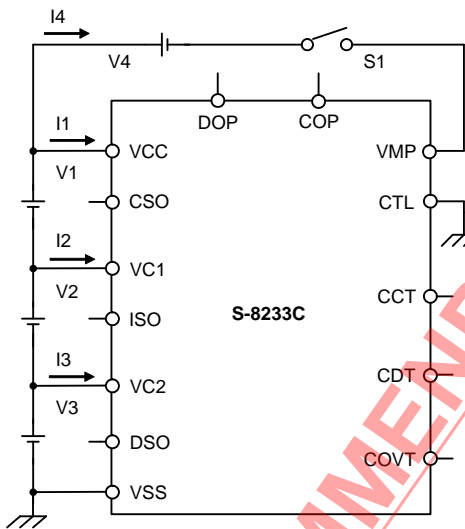

Test circuit 3

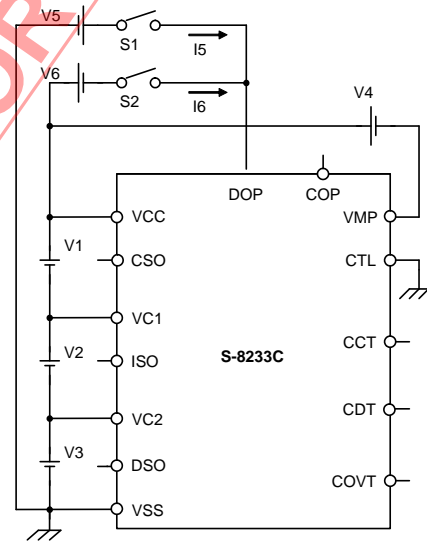

Test circuit 4

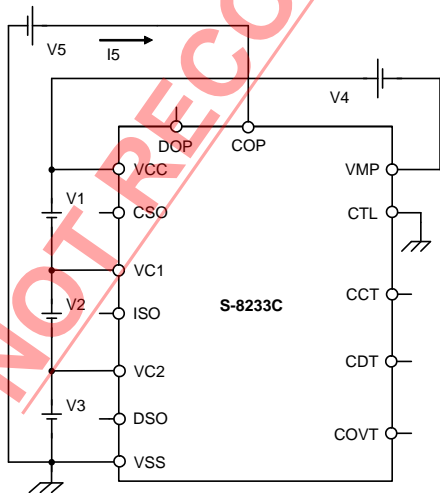

Test circuit 5

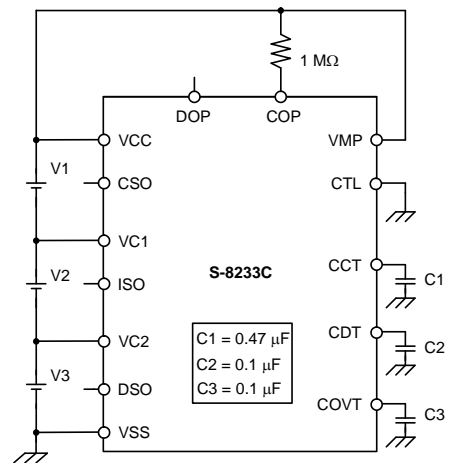

Test circuit 6

Figure 4 (1 / 2)

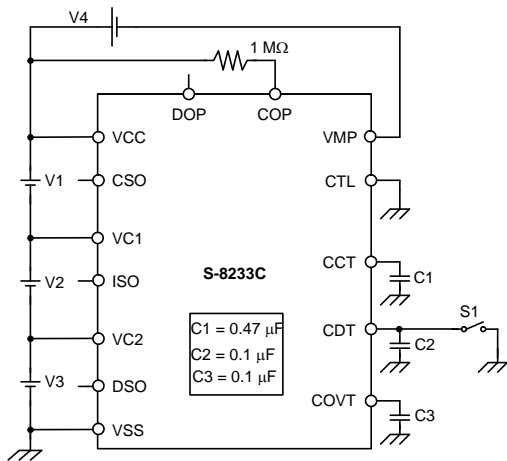

Test circuit 7

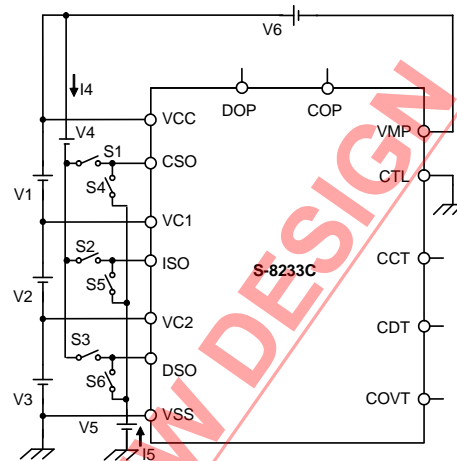

Test circuit 8

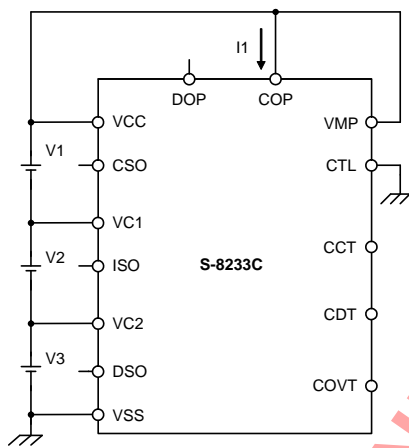

Test circuit 9

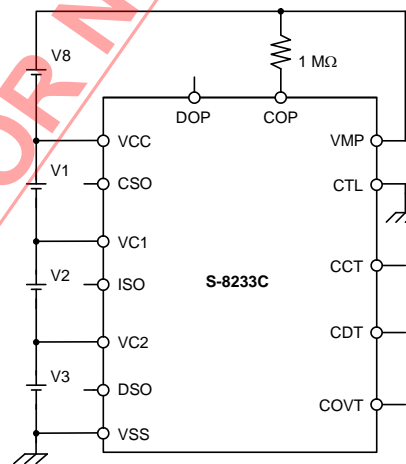

Test circuit 10

Figure 4 (2 / 2)

NOT RECOMMENDED FOR NEW DESIGN

■ **Operation**

Remark Refer to “■ **Battery Protection IC Connection Example**”.

Normal status

This IC monitors the voltages of the three serially-connected batteries and the discharge current to control charging and discharging. If the voltages of all the three batteries are in the range from the overdischarge detection voltage (V_{DD}) to the overcharge detection voltage (V_{CU}), and the current flowing through the batteries becomes equal or lower than a specified value (the VMP pin voltage is equal or lower than overcurrent detection voltage 1), the charging and discharging FETs turn on. In this status, charging and discharging can be carried out freely. This status is called the normal status. In this status, output voltage of CSO, ISO and DSO go ‘low’. VCC pin is shorted by the R_{VCM} resistor.

Overcurrent status

This IC is provided with the three overcurrent detection levels (V_{IOV1} , V_{IOV2} and V_{IOV3}) and the three overcurrent detection delay time (t_{IOV1} , t_{IOV2} and t_{IOV3}) corresponding to each overcurrent detection level.

If the discharging current becomes equal to or higher than a specified value (the VMP pin voltage is equal to or higher than the overcurrent detection voltage) during discharging under normal status and it continues for the overcurrent detection delay time (t_{IOV}) or longer, the discharging FET turns off to stop discharging. This status is called an overcurrent status. The VMP and VCC pins are shorted by the R_{VCM} resistor at this time. The charging FET turns off.

When the discharging FET is off and a load is connected, the VMP pin voltage equals the V_{SS} potential. In this status, output voltage of ISO goes ‘High’.

The overcurrent status returns to the normal status when the load is released and the impedance between the EB- and EB+ pins (see **Figure 9** for a connection example) is 100 M Ω or higher. When the load is released, the VMP pin, which and the VCC pin are shorted with the R_{VCM} resistor, goes back to the V_{CC} potential. The IC detects that the VMP pin potential returns to overcurrent detection voltage 1 (V_{IOV1}) or lower (or the overcurrent detection voltage 2 (V_{IOV2}) or lower if the COVT pin is fixed at the ‘L’ level and overcurrent detection 1 is inhibited) and returns to the normal status. At that time, output voltage of ISO goes ‘Low’.

Overcharge status

If one of the battery voltages becomes higher than the overcharge detection voltage (V_{CU}) during charging under normal status and it continues for the overcharge detection delay time (t_{CU}) or longer, the charging FET turns off to stop charging. This status is called the overcharge status. The ‘H’ level signal is output to the CSO pin corresponding to the battery which exceeds the overcharge detection voltage until the battery becomes equal to lower than the overcharge release voltage (V_{CD}). In this status, output voltage of CSO is ‘High’. The VMP and VCC pins are shorted by the R_{VCM} resistor under the overcharge status.

The overcharge status is released in two cases. The output of CSO pin changes to ‘L’ when the overcharge status is released.

<1> The battery voltage which exceeded the overcharge detection voltage (V_{CU}) falls below the overcharge release voltage (V_{CD}), the charging FET turns on and the normal status returns.

<2> If the battery voltage which exceeded the overcharge detection voltage (V_{CU}) is equal or higher than the overcharge release voltage (V_{CD}), but the charger is removed, a load is placed, and discharging starts, the charging FET turns on and the normal status returns.

The release mechanism is as follows: the discharge current flows through an internal parasitic diode of the charging FET immediately after a load is installed and discharging starts, and the VMP pin voltage decreases by about 0.6 V from the VCC pin voltage momentarily. The IC detects this voltage (overcurrent detection voltage 1 or higher), releases the overcharge status and returns to the normal status.

Overdischarge status

If any one of the battery voltages falls below the overdischarge detection voltage (V_{DD}) during discharging under normal status and it continues for the overdischarge detection delay time (t_{DD}) or longer, the discharging FET turns off and discharging stops. This status is called the overdischarge status. In this status, output voltage of DSO goes 'High'. When the discharging FET turns off, the VMP pin voltage becomes equal to the V_{SS} voltage and the IC's current consumption falls below the power-down current consumption (I_{PDN}). This status is called the power-down status. The VMP and VSS pins are shorted by the R_{VSM} resistor under the overdischarge and power-down statuses.

The power-down status is canceled when the charger is connected and the voltage between VMP and VSS is 3.0 V or higher (overcurrent detection voltage 3). When all the battery voltages becomes equal to or higher than the overdischarge release voltage (V_{DU}) in this status, the overdischarge status changes to the normal status. In this status, output voltage of DSO goes 'Low'.

Delay circuits

The overcharge detection delay time (t_{CU1} to t_{CU3}), overdischarge detection delay time (t_{DD1} to t_{DD3}), and overcurrent detection delay time 1 (t_{IOV1}) are changed with external capacitors (C4 to C6).

The delay times are calculated by the following equations:

| | Min. | Typ. | Max. | |
|---------------|----------------------|-------|-------|------------------|
| $t_{CU}[s]$ | Delay factor (1.07, | 2.13, | 3.19) | $\times C4$ [uF] |
| $t_{DD}[s]$ | Delay factor (0.20, | 0.40, | 0.60) | $\times C5$ [uF] |
| $t_{IOV1}[s]$ | Delay factor (0.10, | 0.20, | 0.30) | $\times C6$ [uF] |

Caution The delay time for overcurrent detection 2 and 3 is fixed by an internal IC circuit. The delay time cannot be changed via an external capacitor.

CTL pin

If the CTL pin is floated under normal status, it is pulled up to the V_{CC} potential in the IC, and both the charging and discharging FETs turn off to inhibit charging and discharging. Both charging and discharging are also inhibited by applying the VCC pin to the CTL pin externally. At this time, the VMP and VCC pins are shorted by the R_{VCM} resistor.

When the CTL pin becomes equal to V_{SS} potential, charging and discharging are enabled and go back to their appropriate statuses for the battery voltages.

Caution Please note unexpected behavior might occur when electrical potential difference between the CTL pin ('L' level) and VSS is generated through the external filter (R_{VSS} and C_{VSS}) as a result of input voltage fluctuations.

0 V battery charging function

This function is used to recharge the three serially-connected batteries after they self-discharge to 0 V. When the 0 V charging start voltage (V_{OCHAR}) or higher is applied to between VMP and VSS by connecting the charger, the charging FET gate is fixed to V_{SS} potential.

When the voltage between the gate sources of the charging FET becomes equal to or higher than the turn-on voltage by the charger voltage, the charging FET turns on to start charging. At this time, the discharging FET turns off and the charging current flows through the internal parasitic diode in the discharging FET. If all the battery voltages become equal to or higher than the overdischarge release voltage (V_{DU}), the normal status returns.

CAUTION In the products without 0 V battery charging function, the resistance between VCC and VMP and between VSS and VMP are lower than the products with 0 V battery charging function. It causes to that overcharge detection voltage increases by the drop voltage of R5 (see Figure 9 for a connection example) with sink current at VMP.

The COP output is undefined below 2.0 V on VCC-VSS voltage in the products without 0 V battery charging function.

Voltage temperature factor

Voltage temperature factor 1 indicates overcharge detection voltage, overcharge release voltage, overdischarge detection voltage, and overdischarge release voltage.

Voltage temperature factor 2 indicates overcurrent detection voltage.

The Voltage temperature factors 1 and 2 are expressed by the oblique line parts in **Figure 5**.

Ex. Voltage temperature factor of overcharge detection voltage Typ.

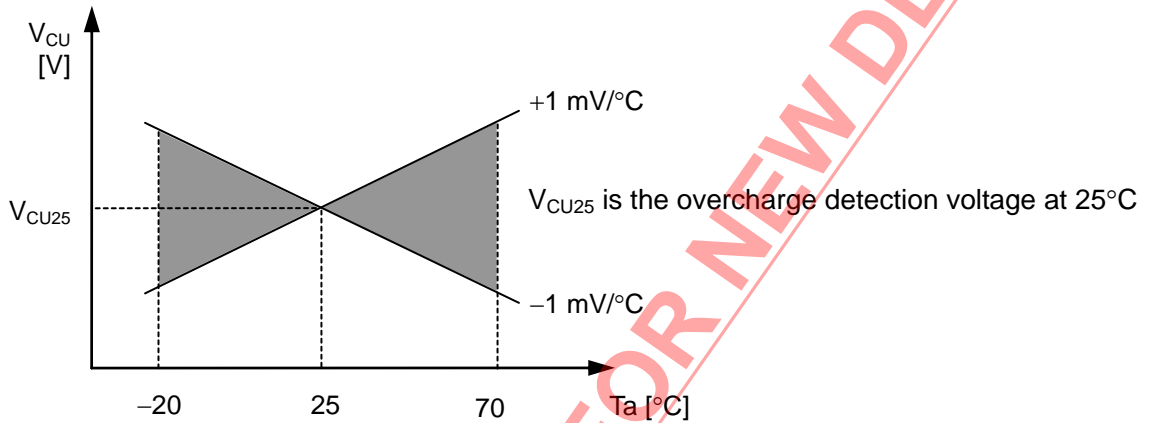
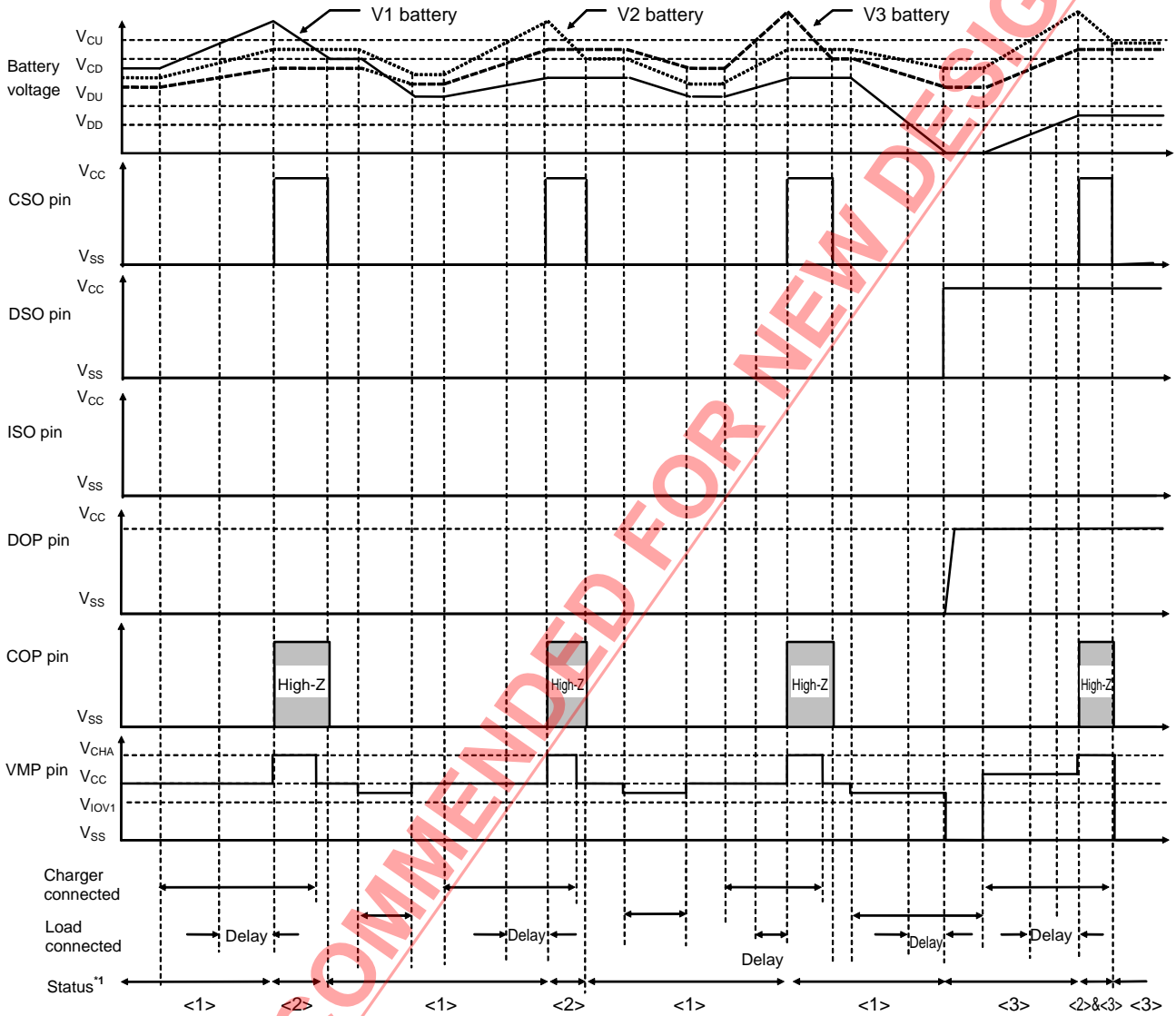

Figure 5

NOT RECOMMENDED FOR NEW DESIGN

■ Timing Charts

1. Overcharge detection



*1. <1> Normal status, <2> Overcharge status, <3> Overdisharge status, <4> Overcurrent status

Remark The charger is assumed to charge with a constant current. V_{CHA} indicates the open voltage of the charger.

Figure 6

2. Overdischarge detection

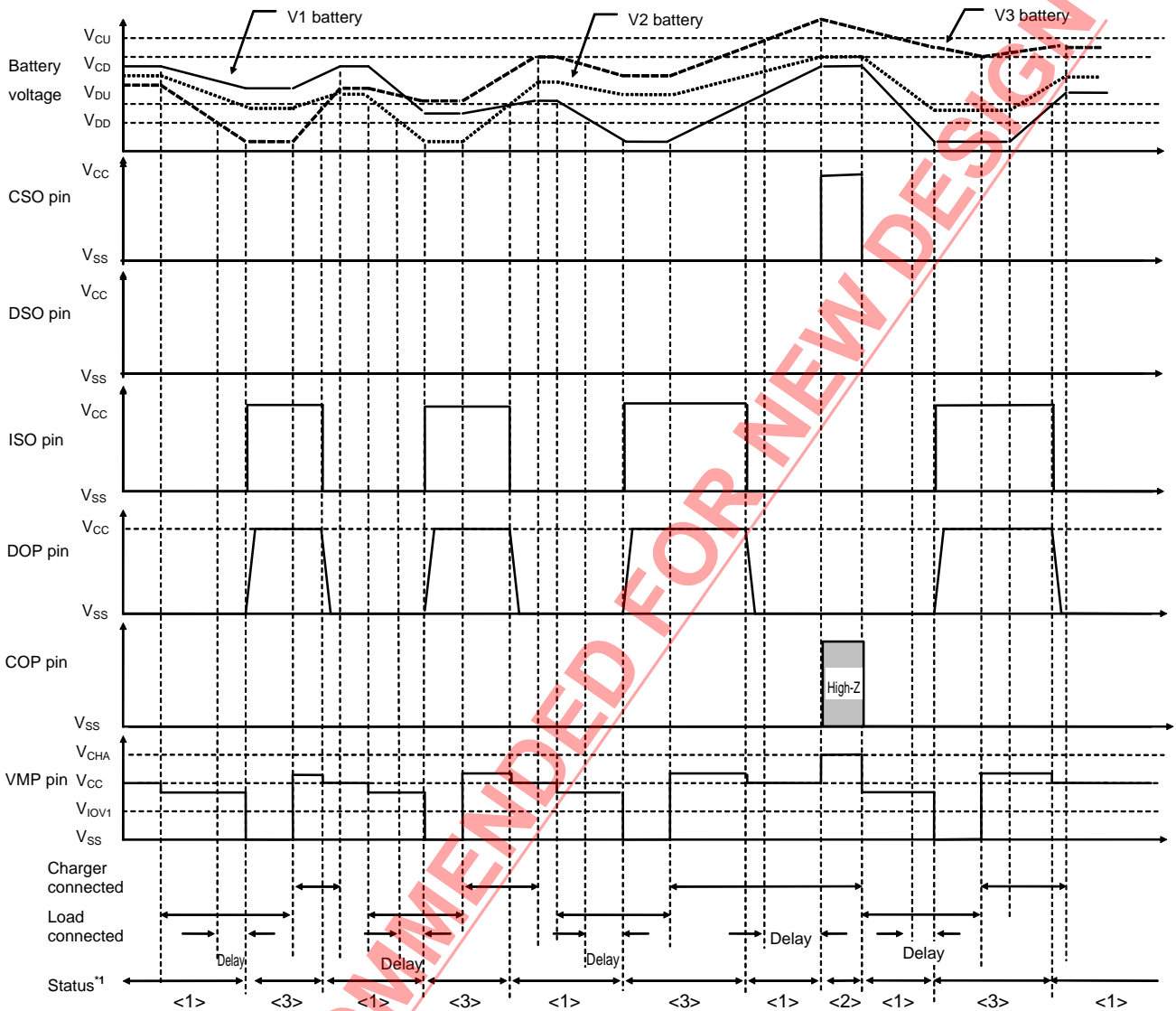

*1. <1> Normal status, <2> Overcharge status, <3> Overdischarge status, <4> Overcurrent status

Remark The charger is assumed to charge with a constant current. V_{CH1} indicates the open voltage of the charger.

Figure 7

NOT RECOMMENDED FOR NEW DESIGN

3. Overcurrent detection

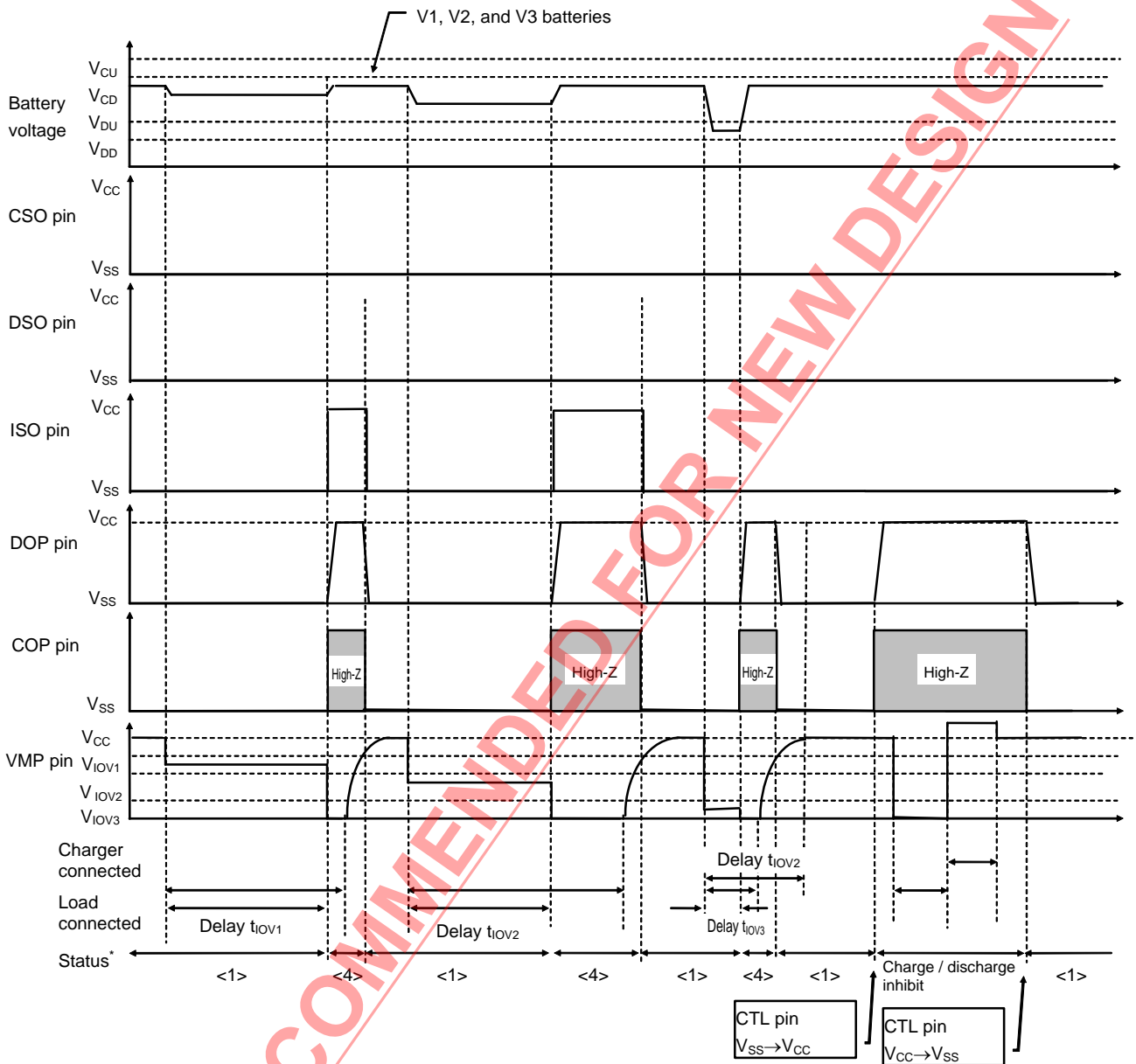

*1. <1> Normal status, <2> Overcharge status, <3> Overdischarge status, <4> Overcurrent status

Figure 8

When the S-8233C series detects overcurrent 1 or overcurrent 2, ISO pin goes 'High'. Delay time from load shorted to ISO pin goes 'High' is TioV2(at that case delay time isn't TioV3).

■ Battery Protection IC Connection Example

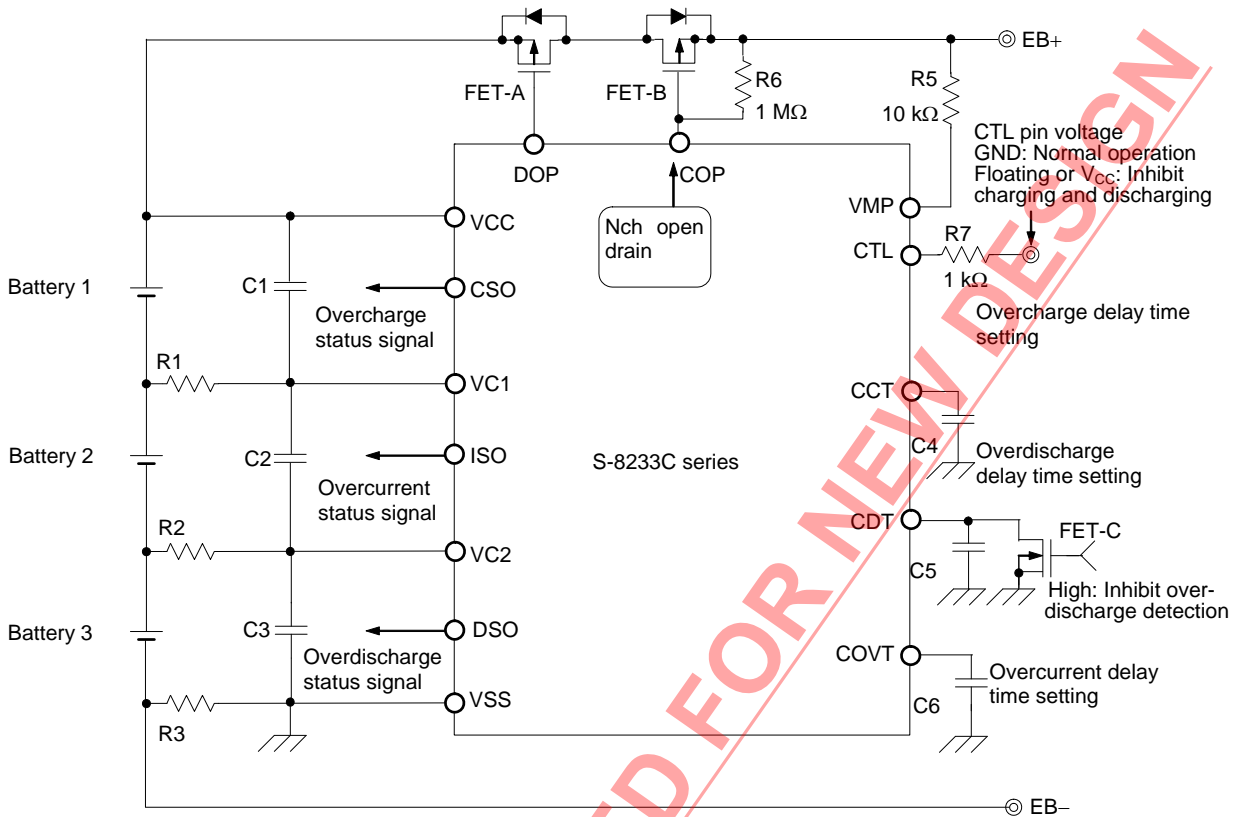

Figure 9

[Description of Figure 9]

- The overcharge detection delay time (t_{CU1} to t_{CU3}), overdischarge detection delay time (t_{DD1} to t_{DD3}), and overcurrent detection delay time (t_{OV1}) are changed with external capacitors (C4 to C6). See the electrical characteristics.
- R6 is a pull-up resistor that turns FET-B off when the COP pin is opened. Connect a 100 k Ω to 1 M Ω resistor.
- R5 is used to protect the IC if the charger is connected in reverse. Connect a 10 k Ω to 50 k Ω resistor.
- If capacitor C6 is absent, rush current occurs when a capacitive load is connected and the IC enters the overcurrent mode. C6 must be connected to prevent it.
- If capacitor C5 is not connected, the IC may enter the overdischarge status due to variations of battery voltage when the overcurrent occurs. In this case, a charger must be connected to return to the normal status. To prevent this, connect an at least 0.01 μ F capacitor to C5.
- If a leak current flows between the delay capacitor connection pin (CCT, CDT, or COVT) and VSS, the delay time increases and an error occurs. The leak current must be 100 nA or less.
- Overdischarge detection can be disabled by using FET-C. The FET-C off leak must be 0.1 μ A or less. If overdischarge is inhibited by using this FET, the current consumption does not fall below 0.1 μ A even when the battery voltage drops and the IC enters the overdischarge detection mode.
- R1, R2, and R3 must be 1 k Ω or less.
- R7 is the protection of the CTL when the CTL pin voltage higher than V_{CC} voltage. Connect a 300 Ω to 5 k Ω resistor. If the CTL pin voltage never greater than the V_{CC} voltage (ex. R7 connect to V_{SS}), without R7 resistor is allowed.

- Caution**
1. The above constants may be changed without notice.
 2. If any electrostatic discharge of 2000 V or higher is not applied to the S-8233C series with a human body model, R1, R2, R3, C1, C2, and C3 are unnecessary.
 3. It has not been confirmed whether the operation is normal or not in circuits other than the above example of connection. In addition, the example of connection shown above and the constant do not guarantee proper operation. Perform through evaluation using the actual application to set the constant.

■ Precautions

- If a charger is connected in the overdischarge status and one of the battery voltages becomes equal to or higher than the overcharge release voltage (V_{CU}) before the battery voltage which is below the overdischarge detection voltage (V_{DD}) becomes equal to or higher than the overdischarge release voltage (V_{DU}), the overdischarge and overcharge statuses are entered and the charging and discharging FETs turn off. Both charging and discharging are disabled. If the battery voltage which was higher than the overcharge detection voltage (V_{CU}) falls to the overcharge release voltage (V_{CD}) due to internal discharging, the charging FET turns on.
If the charger is detached in the overcharge and overdischarge status, the overcharge status is released, but the overdischarge status remains. If the charger is connected again, the battery condition is monitored after that. The charging FET turns off after the overcharge detection delay time, the overcharge and overdischarge statuses are entered.
- If any one of the battery voltages is equal to or lower than the overdischarge release voltage (V_{DU}) when they are connected for the first time, the normal status may not be entered. If the VMP pin voltage is made equal to or higher than the V_{CC} voltage (if a charger is connected), the normal status is entered.
- If the CTL pin floats in power-down mode, it is not pulled up in the IC, charging and discharging may not be inhibited. However, the overdischarge status becomes effective. If the charger is connected, the CTL pin is pulled up, and charging and discharging are inhibited immediately.
- Do not apply an electrostatic discharge to this IC that exceeds the performance ratings of the built-in electrostatic protection circuit.
- ABLIC Inc. claims no responsibility for any disputes arising out of or in connection with any infringement by products including this IC of patents owned by a third party.

■ Characteristics (Typical Data)

1. Detection voltage temperature characteristics

Overcharge detection voltage vs. temperature

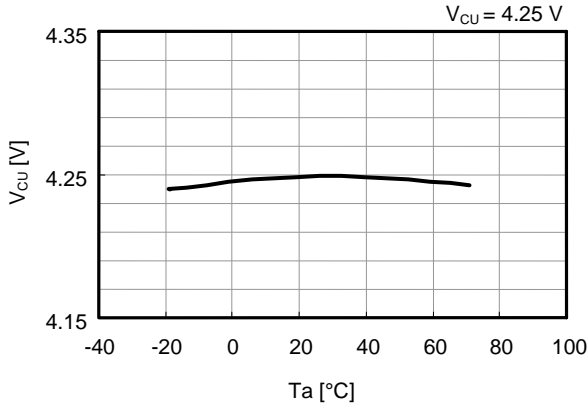

Overcharge release voltage vs. temperature

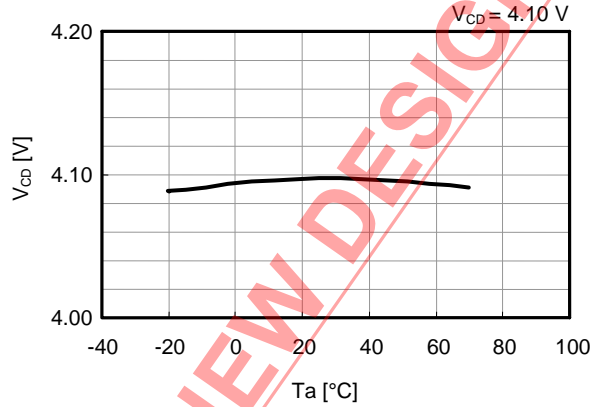

Overdischarge detection voltage vs. temperature

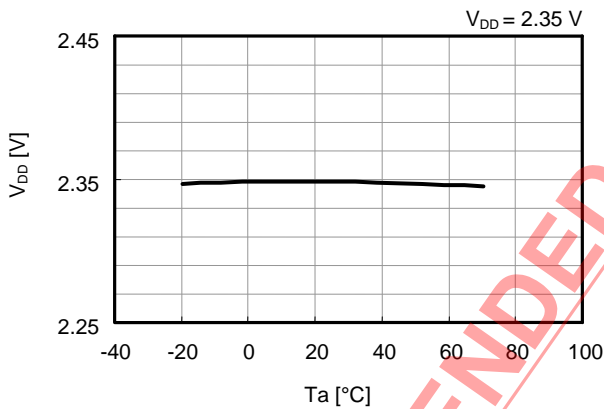

Overdischarge release voltage vs. temperature

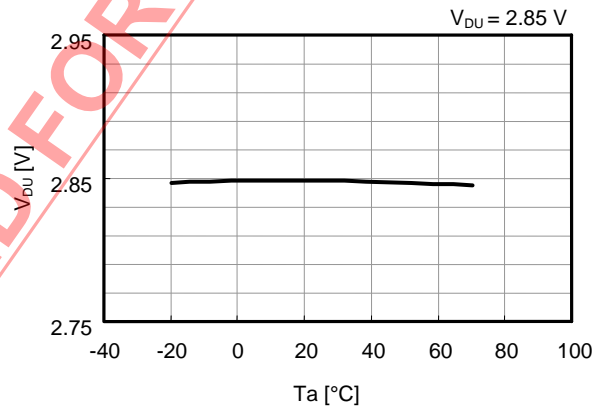

Overcurrent 1 detection voltage vs. temperature

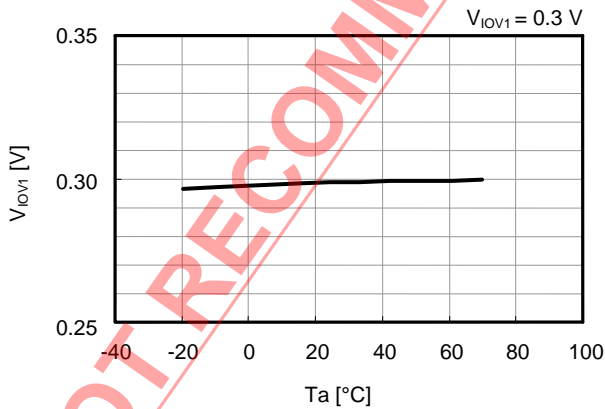

Overcurrent 2 detection voltage vs. temperature

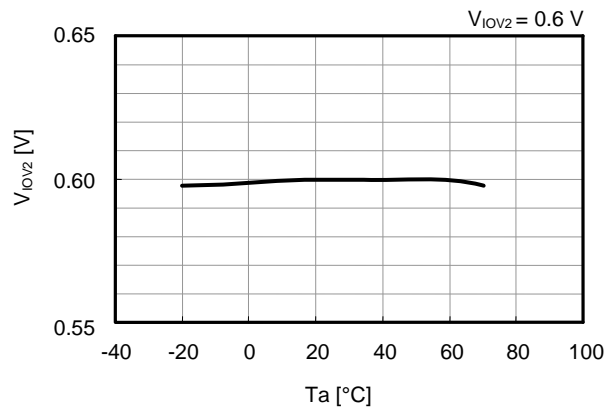

2. Current consumption temperature characteristics

Current consumption vs. temperature in normal mode

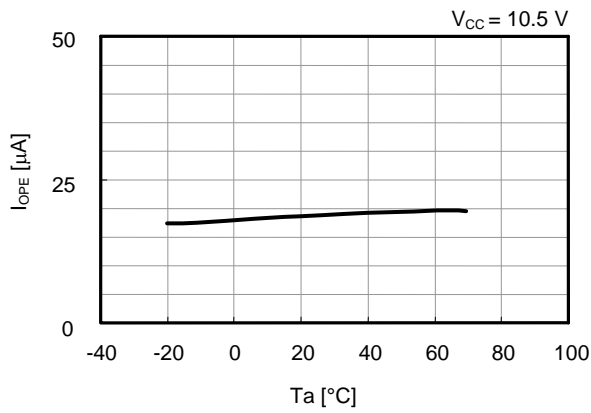

Current consumption vs. temperature in power-down mode

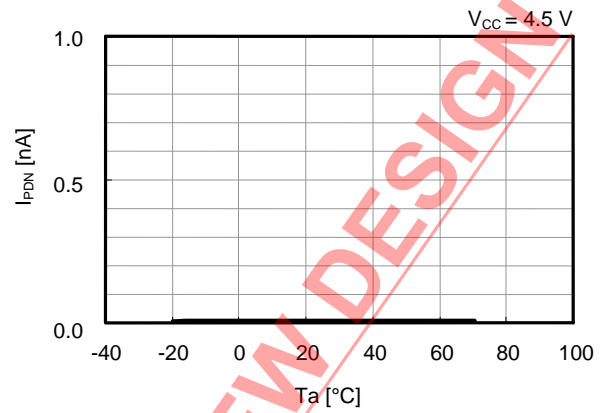

3. Delay time temperature characteristics

Overcharge detection time vs. temperature

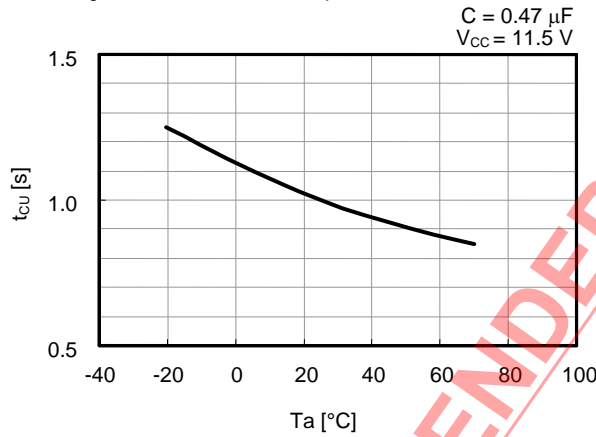

Overdischarge detection time vs. temperature

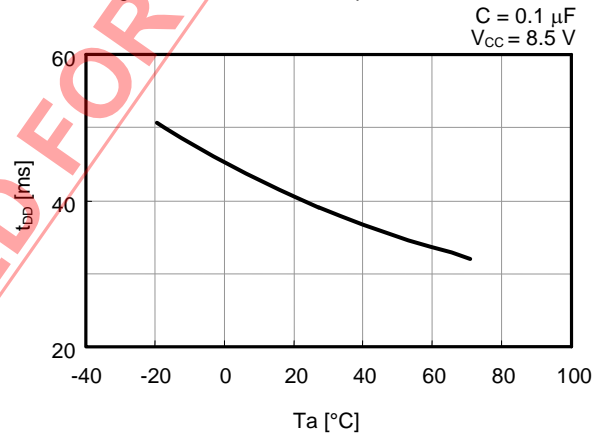

Overcurrent 1 detection time vs. temperature

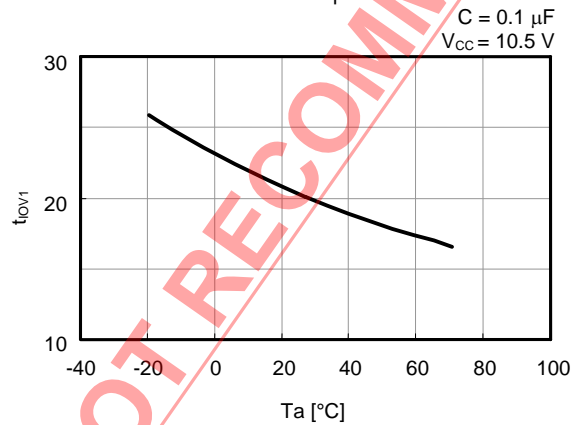

Overcurrent 2 detection time vs. temperature

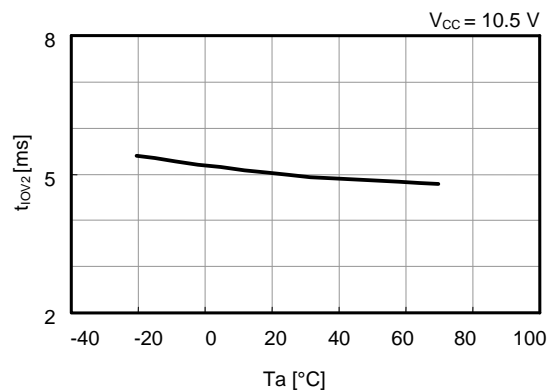

NOT RECOMMENDED FOR NEW DESIGN

Overcurrent 3 (load short) detection time vs. temperature

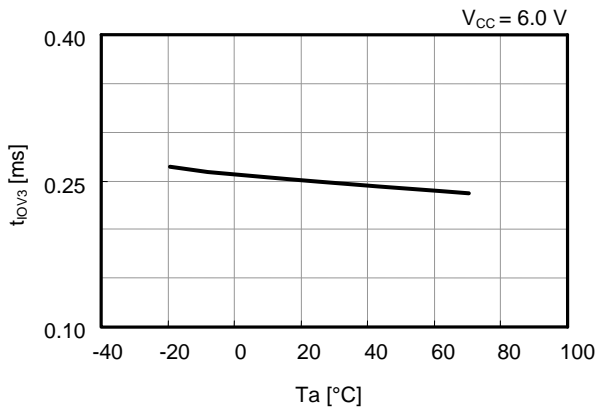

4. Delay time vs. power supply voltage

Overcurrent 3 (load short) detection time vs. power supply voltage

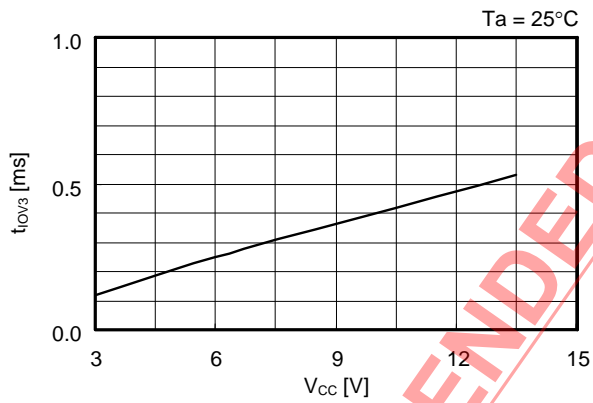

Caution Please design all applications of the S-8233C Series with safety in mind.

NOT RECOMMENDED FOR NEW DESIGN

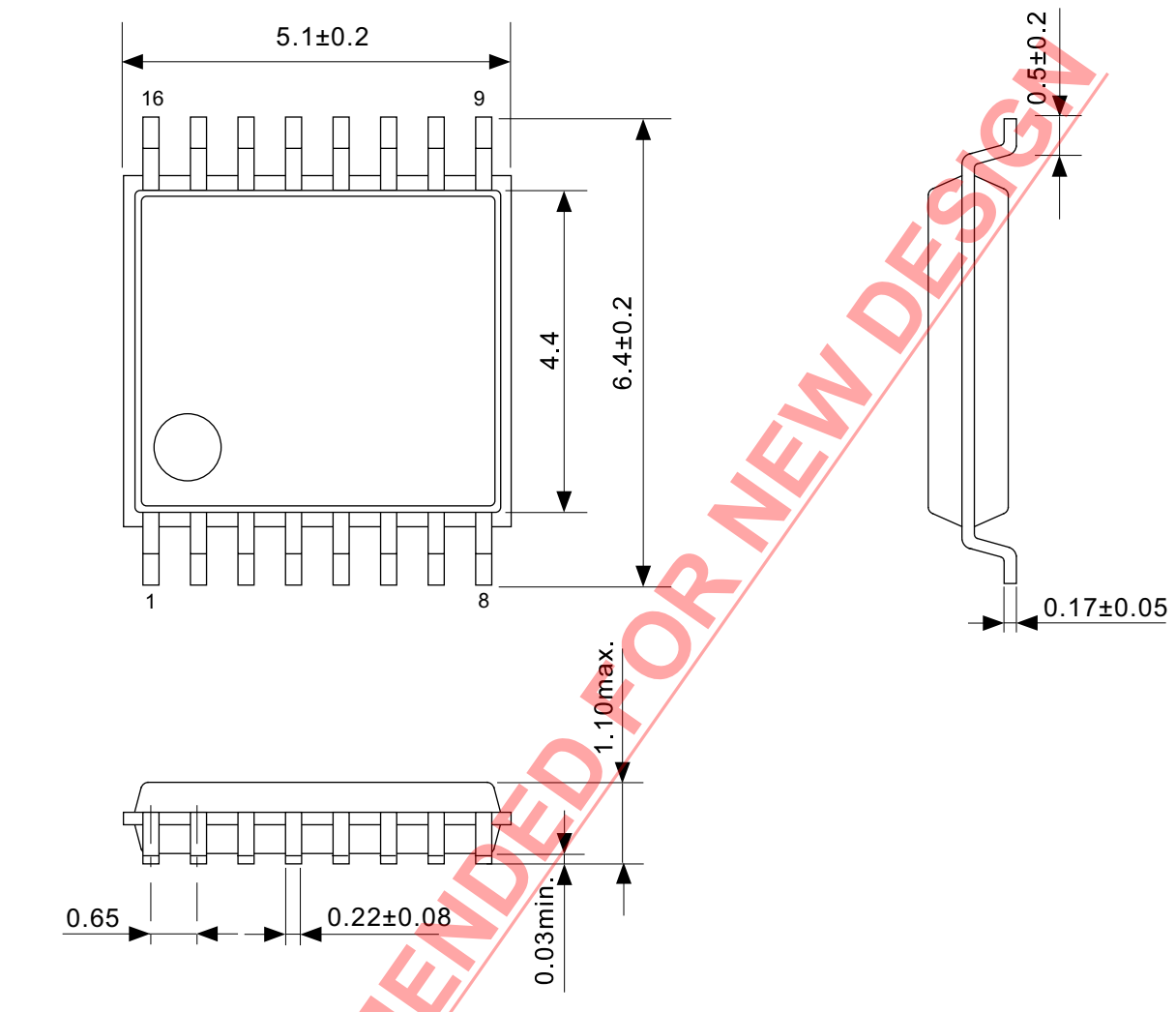

No. FT016-A-P-SD-1.2

| | |
|-------------------|--------------------------|
| TITLE | TSSOP16-A-PKG Dimensions |
| No. | FT016-A-P-SD-1.2 |
| ANGLE | |
| UNIT | mm |
| ABLIC Inc. | |

NOT RECOMMENDED FOR NEW DESIGN

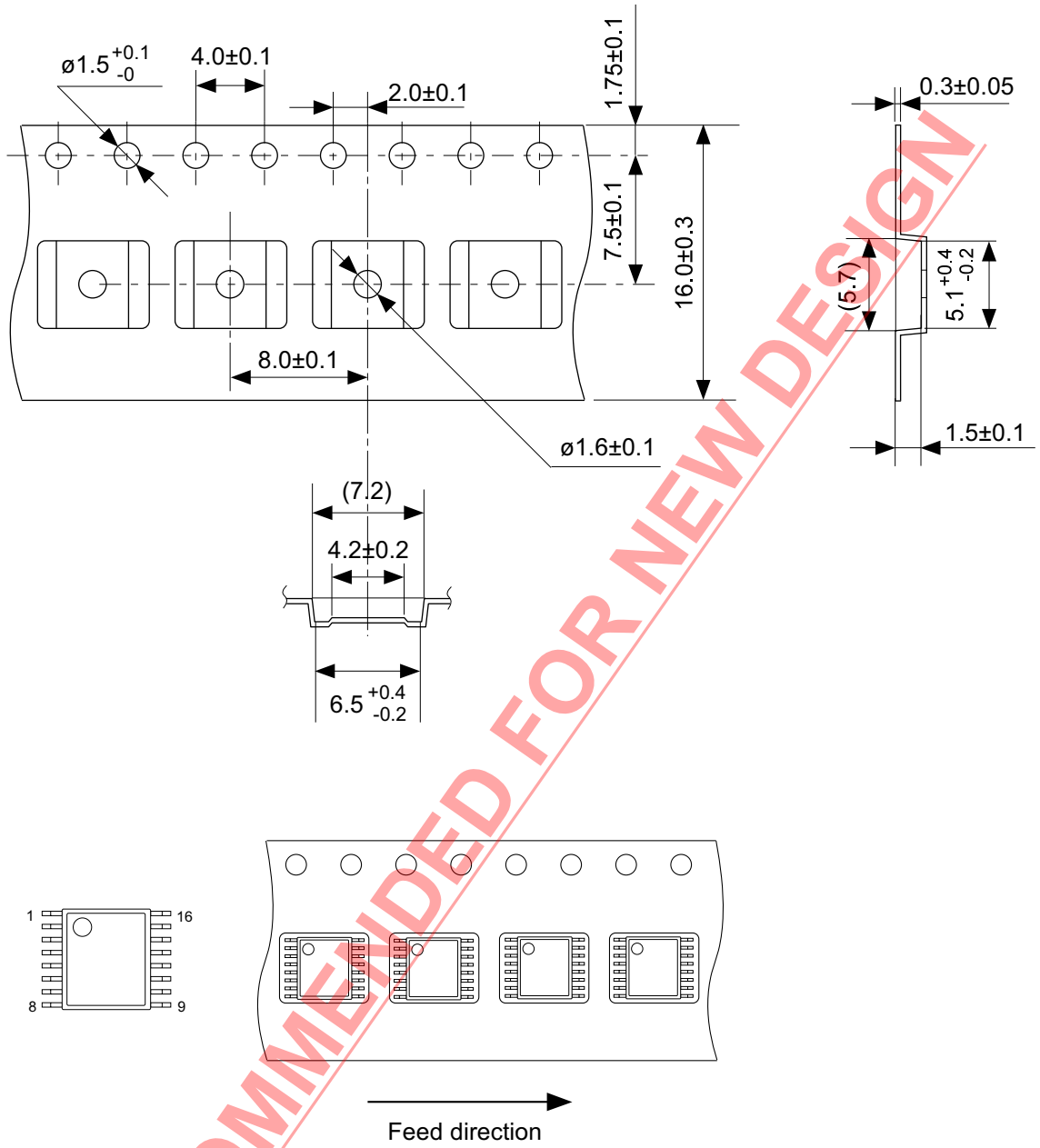

No. FT016-A-C-SD-1.1

| | |
|-------------------|------------------------|
| TITLE | TSSOP16-A-Carrier Tape |
| No. | FT016-A-C-SD-1.1 |
| ANGLE | |
| UNIT | mm |
| ABLIC Inc. | |

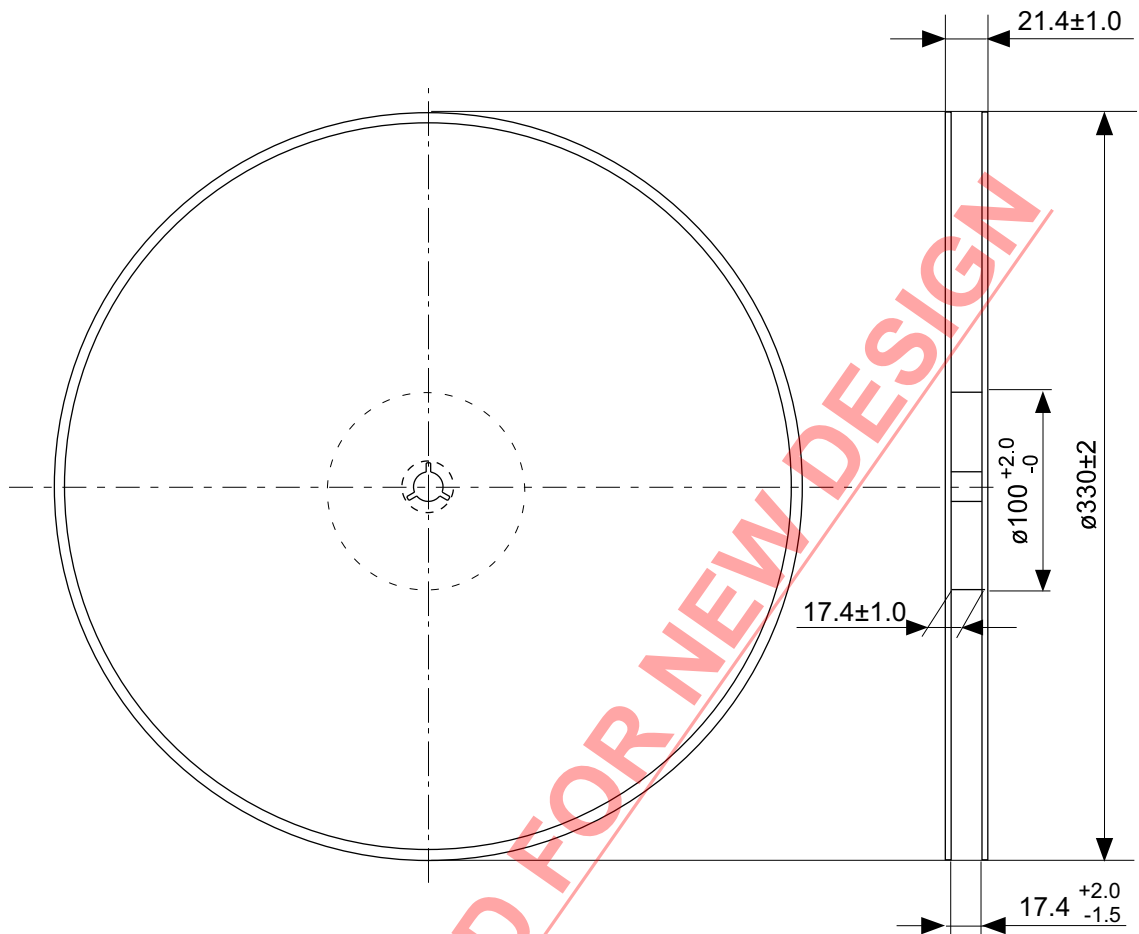

Enlarged drawing in the central part

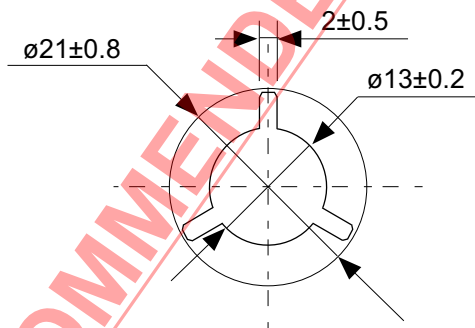

No. FT016-A-R-SD-2.0

| | | | |
|-------------------|------------------|------|-------|
| TITLE | TSSOP16-A- Reel | | |
| No. | FT016-A-R-SD-2.0 | | |
| ANGLE | | QTY. | 2,000 |
| UNIT | mm | | |
| | | | |
| ABLIC Inc. | | | |

Disclaimers (Handling Precautions)

1. All the information described herein (product data, specifications, figures, tables, programs, algorithms and application circuit examples, etc.) is current as of publishing date of this document and is subject to change without notice.
2. The circuit examples and the usages described herein are for reference only, and do not guarantee the success of any specific mass-production design.
ABLIC Inc. is not responsible for damages caused by the reasons other than the products described herein (hereinafter "the products") or infringement of third-party intellectual property right and any other right due to the use of the information described herein.
3. ABLIC Inc. is not responsible for damages caused by the incorrect information described herein.
4. Be careful to use the products within their specified ranges. Pay special attention to the absolute maximum ratings, operation voltage range and electrical characteristics, etc.
ABLIC Inc. is not responsible for damages caused by failures and / or accidents, etc. that occur due to the use of the products outside their specified ranges.
5. When using the products, confirm their applications, and the laws and regulations of the region or country where they are used and verify suitability, safety and other factors for the intended use.
6. When exporting the products, comply with the Foreign Exchange and Foreign Trade Act and all other export-related laws, and follow the required procedures.
7. The products must not be used or provided (exported) for the purposes of the development of weapons of mass destruction or military use. ABLIC Inc. is not responsible for any provision (export) to those whose purpose is to develop, manufacture, use or store nuclear, biological or chemical weapons, missiles, or other military use.
8. The products are not designed to be used as part of any device or equipment that may affect the human body, human life, or assets (such as medical equipment, disaster prevention systems, security systems, combustion control systems, infrastructure control systems, vehicle equipment, traffic systems, in-vehicle equipment, aviation equipment, aerospace equipment, and nuclear-related equipment), excluding when specified for in-vehicle use or other uses. Do not apply the products to the above listed devices and equipments without prior written permission by ABLIC Inc. Especially, the products cannot be used for life support devices, devices implanted in the human body and devices that directly affect human life, etc.
Prior consultation with our sales office is required when considering the above uses.
ABLIC Inc. is not responsible for damages caused by unauthorized or unspecified use of our products.
9. Semiconductor products may fail or malfunction with some probability.
The user of the products should therefore take responsibility to give thorough consideration to safety design including redundancy, fire spread prevention measures, and malfunction prevention to prevent accidents causing injury or death, fires and social damage, etc. that may ensue from the products' failure or malfunction.
The entire system must be sufficiently evaluated and applied on customer's own responsibility.
10. The products are not designed to be radiation-proof. The necessary radiation measures should be taken in the product design by the customer depending on the intended use.
11. The products do not affect human health under normal use. However, they contain chemical substances and heavy metals and should therefore not be put in the mouth. The fracture surfaces of wafers and chips may be sharp. Be careful when handling these with the bare hands to prevent injuries, etc.
12. When disposing of the products, comply with the laws and ordinances of the country or region where they are used.
13. The information described herein contains copyright information and know-how of ABLIC Inc.
The information described herein does not convey any license under any intellectual property rights or any other rights belonging to ABLIC Inc. or a third party. Reproduction or copying of the information from this document or any part of this document described herein for the purpose of disclosing it to a third-party without the express permission of ABLIC Inc. is strictly prohibited.
14. For more details on the information described herein, contact our sales office.

2.0-2018.01