



The worldwide leader in thermal management solutions.

简体中文

Register or Sign Into
Your Account

Cart

News About Us Contact Us Global Manufacturing Shop Aavid

Products Solutions Industries Knowledge Center Design Help

Search By Part Number

Do you already know the part number you're looking for? Check here for pricing, availability and technical data.

I Need Help with Design Services

I Need Help Finding a Solution

Where Do I Start?

Need assistance?

Call us: 1-855-32-AAVID
Email: estore@aavid.com

» [Help Page](#)

Check Distributor Stock

Enter a part number for pricing and availability.

Shoulder Washers

RoHS Compliant

- 40% glass filled polyphenylene sulfide (PPS).
- Chemically inert [no known solvents under 200°C (392°F)]
- Maximum recommended service temperature of 260°C (500°F)
- Recommended torque is 0.565Nm to 0.678Nm (5 to 6 inch-pounds) on all shoulder washers except -7, which has recommended torque of 0.452Nm (4 inch-pounds).

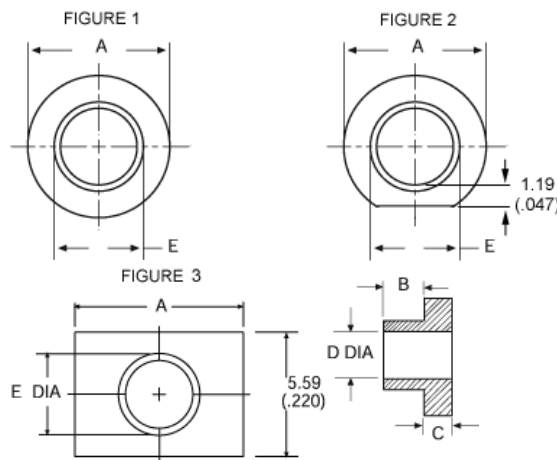

Polyphenylene Sulfide PPS Shoulder Washers

Note: A single gate extension, not to exceed 0.64mm (0.025") in length, is allowable on the outside of all shoulder washers.

Model	RoHS	PCN	A	B	C	D	E	Screw Size	Fig.
7721-1PPSG	RoHS Compliant	Product Change Notice	7.11 (0.280)	3.18 (0.125)	1.07 (0.042)	2.84 (0.112)	3.81 (0.150)	4	1
7721-3PPSG	RoHS Compliant	Product Change Notice	7.11 (0.280)	3.18 (0.125)	1.07 (0.042)	2.84 (0.112)	3.56 (0.140)	4	1
7721-4PPS	RoHS Compliant	N/A	7.92 (0.312)	.79 (0.081)	1.19 (0.047)	3.71 (0.146)	4.83 (0.190)	6	1
7721-5PPSG	RoHS Compliant	Product Change Notice	7.92 (0.312)	.79 (0.031)	1.19 (0.047)	3.66 (0.144)	4.50 (0.177)	6	1
7721-6PPSG	RoHS Compliant	Product Change Notice	7.11 (0.280)	.79 (0.031)	1.19 (0.047)	3.00 (0.118)	3.68 (0.145)	4	1
7721-7PPSG*	RoHS Compliant	Product Change Notice	5.46 (0.215)	.81 (0.032)	1.02 (0.040)	2.95 (0.116)	3.43 (0.139)	4	1
7721-8PPSG	RoHS Compliant	Product Change Notice	6.22 (0.245)	1.02 (0.040)	1.02 (0.040)	3.02 (0.119)	3.56 (0.140)	4	2
7721-9PPSG	RoHS Compliant	N/A	7.62 (0.300)	1.22 (0.048)	1.40 (0.055)	2.97 (0.117)	3.56 (0.140)	4**	3
7721-10PPSG	RoHS Compliant	Product Change Notice	7.62 (0.300)	2.41 (0.095)	1.40 (0.055)	2.97 (0.117)	3.56 (0.140)	4**	3

* Design allows insertion in the tab of a TO-220.

** Also for M3 Screw

Nylon Shoulder Washers

RoHS Compliant

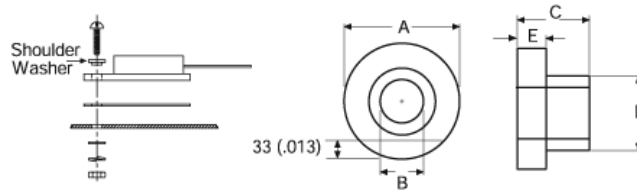

Model	RoHS	PCN	A	B	C	D	E
7721-11NG Formerly Motorola p/n B51547F003	RoHS Compliant	 Product Change Notice	7.80 / 8.05 (0.307 / 0.317)	2.87 / 3.00 (0.113 / 0.118)	3.56 / 3.81 (0.140 / 0.150)	3.76 / 3.89 (1.48 / 1.53)	1.09 / 1.35 (0.043 / 0.053)
7721-12N Formerly Motorola p/n B51547F005	RoHS Compliant	N/A	9.40 / 9.65 (0.370 / .380)	3.84 / 4.09 (0.151 / .161)	2.16 / 2.41 (0.085 / .095)	6.10 / 6.35 (0.240 / .250)	1.02 / 1.27 (0.040 / .050)
7721-13NG Formerly Motorola p/n B51547F011	RoHS Compliant	 Product Change Notice	5.89 / 6.05 (0.232 / 0.238)	2.87 / 3.00 (0.113 / 0.118)	4.11 / 4.45 (0.162 / 0.175)	3.43/ 3.56 (0.135 / 0.140)	1.19/ 1.40 (0.047 / 0.055)
7721-14N Formerly Motorola p/n B51547F018	RoHS Compliant	N/A	6.40 / 6.60 (0.252 / .260)	2.90 / 3.10 (0.114 / .122)	2.69 / 2.90 (0.106 / .114)	3.89 / 4.09 (0.153 / .161)	
7721-15NG Formerly Motorola p/n B51547F019	RoHS Compliant	 Product Change Notice	5.59 / 6.10 (0.220 / 0.240)	2.90 / 2.95 (0.114 / 0.116)	1.73 / 1.91 (0.068 / 0.075)	3.43 / 3.58 (0.135 / 0.141)	.51 / 0.64 (0.020 / 0.025)

Customer Assistance

- [Contact Us](#)
- [Get Design Assistance](#)
- [Find a Distributor](#)
- [Find a Sales Rep](#)
- [Request a Quote](#)
- [Placing an Order](#)
- [Terms and Conditions](#)
- [Returns](#)

Popular Products

- [Fans](#)
- [Extrusions](#)
- [Board Level](#)
- [Liquid Cooling](#)
- [Heat Pipe Technology](#)
- [Heat Sink Accessories](#)
- [Interface Materials](#)

Our Company

- [News and Events](#)
- [Management Team](#)
- [Worldwide Locations](#)
- [Directions to Headquarters](#)
- [Disclaimer](#)
- [Customer Survey](#)
- [Privacy Policy](#)

Connect with Aavid

Sign up for Aavid News & Alerts

Like / Follow / Connect



© Copyright 2014 Aavid Thermalloy, LLC.

USA: 1.855.32.AAVID Europe: 39.051.764002 Asia: 86.21.6115.2000 x 8122