



Aavid - The worldwide leader in thermal management solutions

Products

Shop Aavid

Industries

Knowledge Center

Design Help

Stanchion Pads
8923-2G

ENTER QTY:

VIEW PRICE

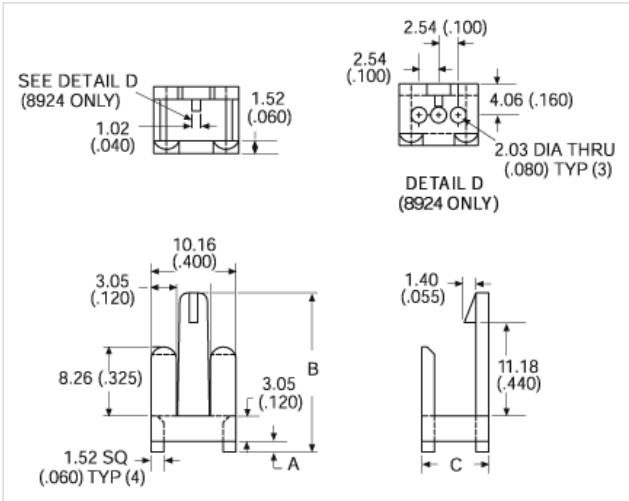

Stanchion Pad will fit TO-220. Reduces stress on leads during wave solder and post-soldering operations. Provides stable mount to resist shock and vibration damage to leads. Material is nylon 6/6 rated 94 V-O

- A Dim: 1.27 (0.050)
- B Dim: 19.05 (0.750)
- C Dim: 7.87 (0.310)
- Tolerances +/- 0.25mm (0.010") unless otherwise specified.

[Download PCN](#)

Need assistance?
Call us: 1-855-32-AAVID
Email: estore@aavid.com
[» Help Page](#)

Check Distributor Stock
Enter a part number for pricing and availability.
 go!

- > [Request a Sample](#)
- > [Request a Quote](#)
- > [Ask an Engineer](#)

The Fine Print
[Product Return Policy](#)
[Terms & Conditions](#)
[Privacy Policy](#)

Customer Assistance

- Contact Us
- Get Design Assistance
- Find a Distributor
- Find a Sales Rep
- Request a Quote
- Placing an Order
- Terms and Conditions
- Returns

Popular Products

- Fans
- Extrusions
- Board Level
- Liquid Cooling
- Heat Pipe Technology
- Heat Sink Accessories
- Interface Materials

Our Company

- News and Events
- Management Team
- Worldwide Locations
- Disclaimer
- Customer Survey
- Privacy Policy
- Careers

Connect with Aavid



© Copyright 2016 Aavid Thermalloy, LLC.