

CONN P2	FIG NO	CONN P1 TYPE																																	
		BJ77								BJ377								BJ77TL								BJ77FL									
		A1	A2	A3	A4	A5	A6	A7	A8	A9	A1	A2	A3	A4	A5	A6	A7	A8	A1	A2	A3	A4	A5	A6	A7	A8	A1	A2	A3	A4	A5	A6	A7	A8	
PL74	1A	-1	-2	-3	-4	-5	-6	-397	-398	-533	-7	-8	-9	-10	-11	-12	-399	-400	-13	-14	-15	-17	-17	-18	-401	-402	-19	-20	-21	-22	-23	-24	-403	-404	
PL75	1A	-25	-26	-27	-28	-29	-30	-405	-406	-534	-31	-32	-33	-34	-35	-36	-407	-408	-37	-38	-39	-40	-41	-42	-409	-410	-43	-44	-45	-46	-47	-48	-411	-412	
PL375	1B	-49	-50	-51	-52	-53	-54	-413	-414	-535	-55	-56	-57	-58	-59	-60	-415	-416	-61	-62	-63	-64	-65	-66	-417	-418	-67	-68	-69	-70	-71	-72	-419	-420	
PL75FL	1A	-73	-74	-75	-76	-77	-78	-421	-422	-536	-79	-80	-81	-82	-83	-84	-423	-424	-85	-86	-87	-88	-89	-90	-425	-426	-91	-92	-93	-94	-95	-96	-427	-428	
CJ70TL	2A	-97	-98	-99	-100	-101	-102	-429	-430	-537	-103	-104	-105	-106	-107	-108	-431	-432	-109	-110	-111	-112	-113	-433	-434	-114	-115	-116	-117	-118	-119	-435	-436		
CJ70	2A	-120	-121	-122	-123	-124	-437	-438	-538	-125	-126	-127	-128	-129	-130	-439	-440	-131	-132	-133	-134	-135	-136	-441	-442	-137	-138	-139	-140	-141	-142	-443	-444		
CJ370	2B	-143	-144	-145	-146	-147	-148	-445	-446	-539	-149	-150	-151	-152	-153	-447	-448	-154	-155	-156	-157	-158	-159	-449	-450	-160	-161	-162	-163	-164	-165	-451	-452		
CJ70FL	2A	-166	-167	-168	-169	-170	-171	-453	-454	-540	-172	-173	-174	-175	-176	-177	-455	-456	-178	-179	-180	-181	-182	-183	-457	-458	-184	-185	-186	-187	-188	-459	-460		
BJ79TL	3A	-189	-190	-191	-192	-193	-194	-461	-462	-541	-195	-196	-197	-198	-199	-200	-463	-464	-201	-202	-203	-204	-205	-465	-466	-206	-207	-208	-209	-210	-211	-467	-468		
BJ79	3A	-212	-213	-214	-215	-216	-469	-470	-542	-217	-218	-219	-220	-221	-222	-471	-472	-223	-224	-225	-226	-227	-228	-473	-474	-229	-230	-231	-232	-233	-234	-475	-476		
BJ379	3B	-235	-236	-237	-238	-239	-240	-477	-478	-543	-241	-242	-243	-244	-245	-479	-480	-246	-247	-248	-249	-250	-251	-481	-482	-252	-253	-254	-255	-256	-257	-483	-484		
BJ79FL	3A	-258	-259	-260	-261	-262	-263	-485	-486	-544	-264	-265	-266	-267	-268	-487	-488	-269	-270	-271	-272	-273	-274	-489	-490	-275	-276	-277	-278	-279	-280	-491	-492		
PL71	4	-281	-282	-283	-284	-285	-286	-493	-494	-545	-287	-288	-289	-290	-291	-292	-495	-496	-293	-294	-295	-296	-297	-298	-497	-498	-299	-300	-301	-302	-303	-304	-499	-500	
BJ74TL	5A	-305	-306	-501	-502	-309	-310	-501	-502	-546	-311	-312	-313	-314	-315	-316	-503	-504	15	-317	-318	-319	-320	-321	-505	-506	-322	-323	-324	-325	-326	-327	-507	-508	
BJ74	5A	-328	-329	-330	-331	-332	-333	-334	-335	-547	-336	-337	-338	-339	-340	-341	-342	-343	-344	-513	-514	-345	-346	-347	-348	-349	-350	-515	-516	-517	-518	-519	-520	-521	-522
BJ374	5B	-351	-352	-353	-354	-355	-356	-357	-358	-548	-359	-360	-361	-362	-363	-364	-365	-366	-367	-368	-369	-370	-371	-372	-373	-374	-375	-376	-377	-378	-379	-380	-381	-382	
BJ74FL	5A	-374	-375	-376	-377	-378	-379	-525	-526	-549	-380	-381	-382	-383	-384	-385	-527	-528	-386	-387	-388	-389	-390	-391	-529	-530	-392	-393	-394	-395	-396	-397	-531	-532	

DATA CONTAINED IN THIS DOCUMENT IS PROPRIETARY TO TROMPETER ELECTRONICS, INC. AND SHALL NOT BE DISCLOSED, COPIED OR USED FOR PROCUREMENT OR MANUFACTURE WITHOUT EXPRESS WRITTEN PERMISSION OF TROMPETER ELECTRONICS, INC.

REVISIONS		22-04	SH 1
REV	DESCRIPTION	DATE	APPROVED
N	REVISED PER ECO 15418	4/2/04	[Signature]

RED INDICATES ORIGINAL

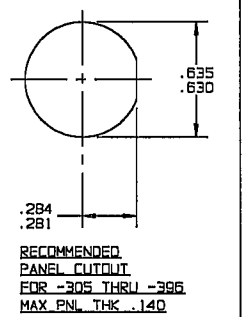
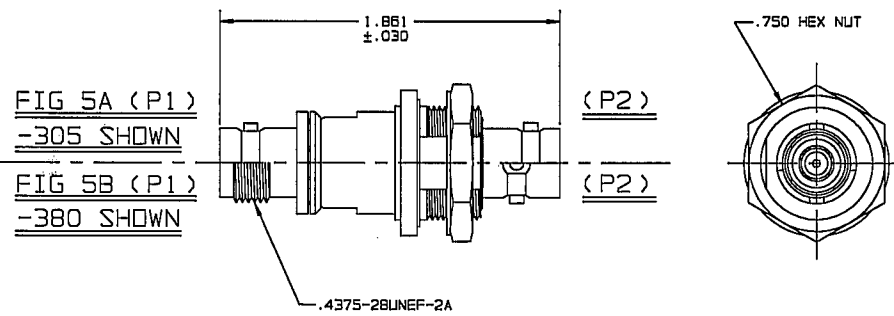
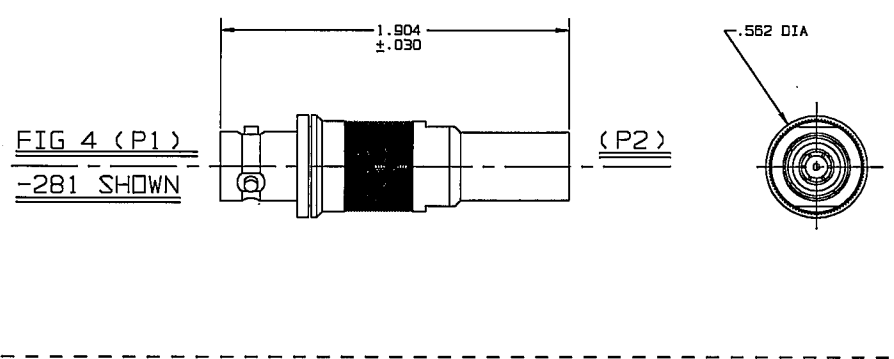
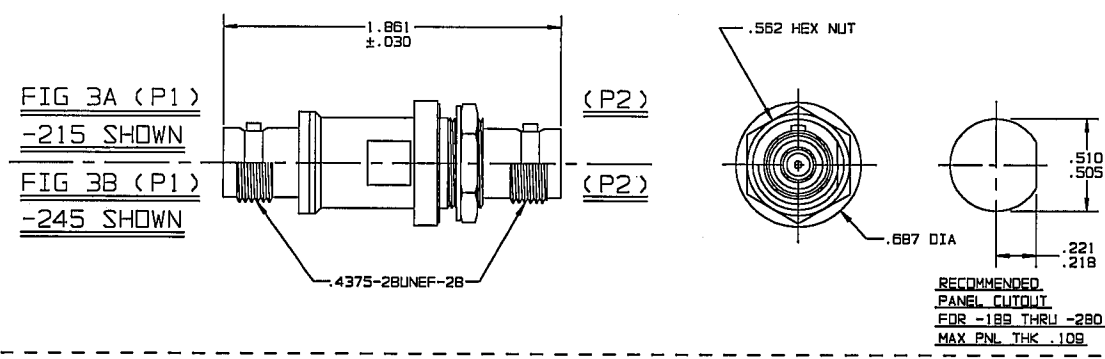
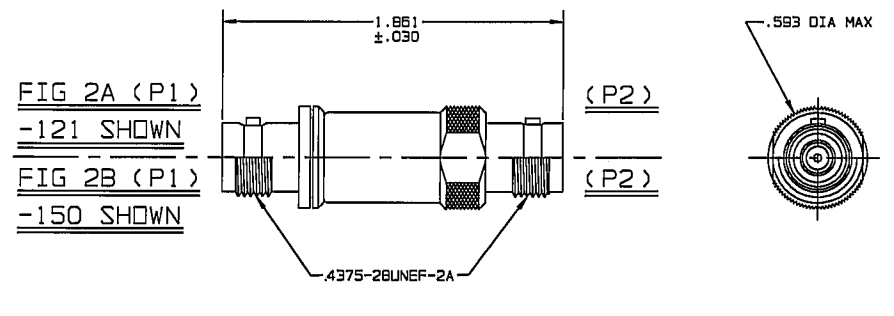
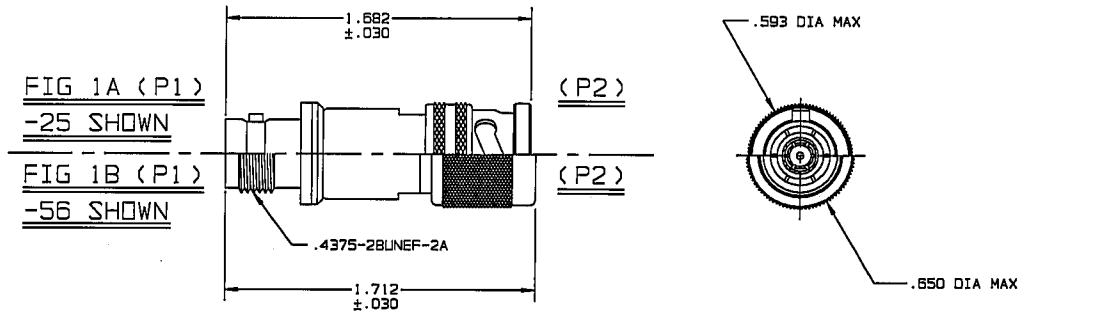

RECOMMENDED PANEL CUTOUT FOR -305 THRU -396 MAX PNL THK .140

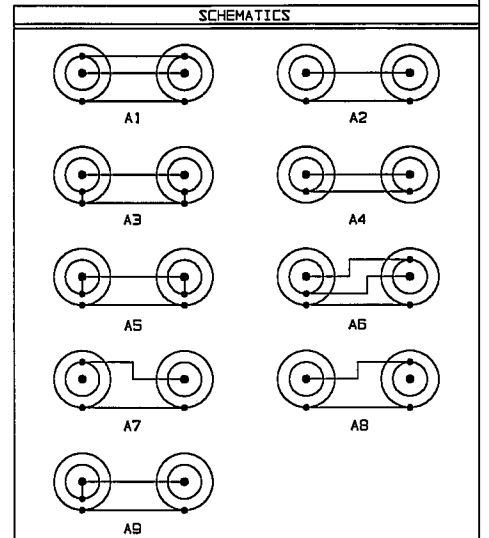

- △ FOR SCHEMATIC "A4", ADD .280 FOR OVERALL LENGTH DIM
- △ FOR "A1" VERSION SEE 3-0236, BJ78FL
- △ FOR "A1" VERSION SEE 3-0058, BJ378
- △ FOR "A1" VERSION SEE 3-0002, BJ78
- △ FOR "A1" VERSION SEE 305-0506, BJ78TL
- △ FOR "A1" VERSION SEE 3-0224, BJ78FL
- △ FOR "A1" VERSION SEE 3-0060, AD378
- △ FOR "A1" VERSION SEE 3-0213, AD78TL
- △ FOR "A1" VERSION SEE 305-0140, AD78

- △ FOR "A1" VERSION SEE 3-0221, BJ73FL
- △ FOR "A1" VERSION SEE 3-0059, BJ373
- △ FOR "A1" VERSION SEE 3-0057, BJ73
- △ FOR "A1" VERSION SEE 3-0215, BJ73TL

- 14. EXAMPLE OF COMPLETE MODEL NO:
AD-BJ77-A1-PL74
ADAPTER (P1) CONN TYPE SCHEMATIC
- 13. EXAMPLE OF COMPLETE PART NO:
22-04-X
BASIC NO DASH NO

- 3. WITHIN SERIES ADAPTER 2-LUG, 3-LUG, 4-LUG & THREADED CONCENTRIC TWINAX/TRIAX RECEPTACLE TO 2-LUG, 3-LUG, 4-LUG & THREADED CONCENTRIC TWINAX/TRIAX PLUG/RECEPTACLE
- 2. FINISH: TFS-1A (NICKLE)
- 1. ALL DIM ARE IN INCHES

TITL: UNLESS SPECIFIED .XX ±.005 .XXX ±.005 .XXXX ANGLES MATERIAL: FINISH: SCALE: 2/1 DATE: 5-20-95 SHEET: 1C	TROMPETER ELECTRONICS, INC. TITLE: ADAPTER: BJ77/TL/ FL/377 TO CONCENTRIC TWINAX/TRIAX SERIES SIZE: B 14949 DRAWING NO: 22-04 REV: N
---------------------------------------------------------------------------------------------------------------------------------------	------------------------------------------------------------------------------------------------------------------------------------------------------------------