

1.00mm Pitch

Series 6208 - ZIF Vertical SMT

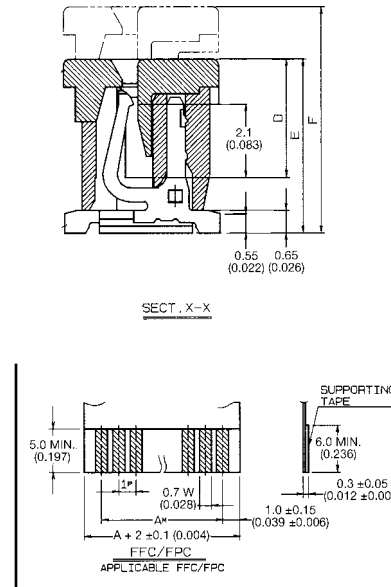

WITHOUT BOSS

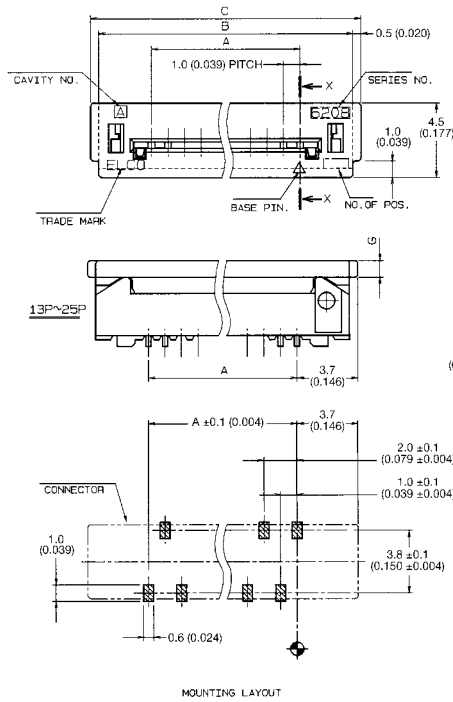

Kind	Tolerance		
	P	W	M
FFC	±0.05	±0.03	±0.1
FPC	±0.02	+0.07 -0.05	±0.05

WITH BOSS

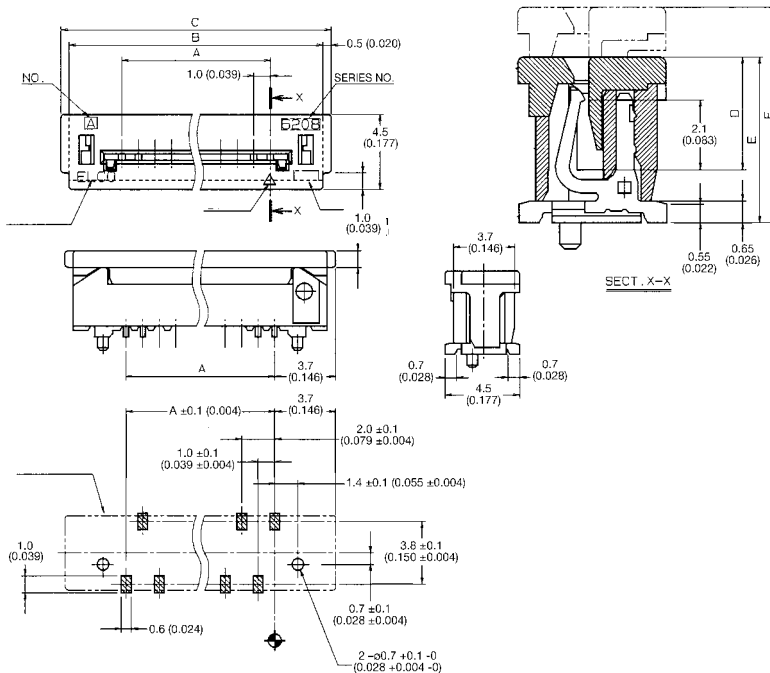

No. of Contacts	Assembly Number	A	B	C	D	E	F	G	Qty. Per Box
05	00 6208 XXX 005 000	4.0 (0.157)	10.4 (0.409)	11.4 (0.449)	3.4 (0.134)	5.0 (0.197)	6.5 (0.256)	0.8 (0.031)	3100
06	006	5.0 (0.197)	11.4 (0.449)	12.4 (0.488)	↑	↑	↑	↑	2900
07	007	6.0 (0.236)	12.4 (0.488)	13.4 (0.528)	↑	↑	↑	↑	2700
08	008	7.0 (0.276)	13.4 (0.528)	14.4 (0.567)	↑	↑	↑	↑	2500
09	009	8.0 (0.315)	14.4 (0.567)	15.4 (0.606)	↑	↑	↑	↑	2300
10	010	9.0 (0.354)	15.4 (0.606)	16.4 (0.646)	↑	↑	↑	↑	2200
11	011	10.0 (0.394)	16.4 (0.646)	17.4 (0.685)	↑	↑	↑	↑	2000
12	012	11.0 (0.433)	17.4 (0.685)	18.4 (0.724)	↑	↑	↑	↑	1900
13	013	12.0 (0.472)	18.4 (0.724)	19.4 (0.764)	↑	↑	↑	↑	1800
14	014	13.0 (0.512)	19.4 (0.764)	20.4 (0.803)	↑	↑	↑	↑	1700
15	015	14.0 (0.551)	20.4 (0.803)	21.4 (0.843)	↑	↑	↑	↑	1600
16	016	15.0 (0.591)	21.4 (0.843)	22.4 (0.882)	↑	↑	↑	↑	1600
17	017	16.0 (0.630)	22.4 (0.882)	23.4 (0.921)	↑	↑	↑	↑	1500
18	018	17.0 (0.669)	23.4 (0.921)	24.4 (0.961)	↑	↑	↑	↑	1400
19	019	18.0 (0.709)	24.4 (0.961)	25.4 (1.000)	↓	↓	↓	↓	1400
20	020	19.0 (0.748)	25.4 (1.000)	26.4 (1.039)	3.4 (0.134)	5.0 (0.197)	6.5 (0.256)	0.8 (0.031)	1300
21	021	20.0 (0.787)	26.4 (1.039)	27.4 (1.079)	3.6 (0.142)	5.2 (0.205)	6.7 (0.264)	1.0 (0.039)	1300
22	022	21.0 (0.827)	27.4 (1.079)	28.4 (1.118)	↑	↑	↑	↑	1200
23	023	22.0 (0.866)	28.4 (1.118)	29.4 (1.157)	↑	↑	↑	↑	1200
24	024	23.0 (0.906)	29.4 (1.157)	30.4 (1.197)	↓	↓	↓	↓	1100
25	025	24.0 (0.945)	30.4 (1.197)	31.4 (1.236)	3.6 (0.142)	5.2 (0.205)	6.7 (0.264)	1.0 (0.039)	1100
26	00 6208 500 026 600	25.0 (0.984)	31.4 (1.236)	32.4 (1.276)	3.9 (0.154)	5.5 (0.217)	7.0 (0.276)	1.3 (0.051)	1100
28	00 6208 500 028 600	27.0 (1.063)	33.4 (1.315)	34.4 (1.354)	3.9 (0.154)	5.5 (0.217)	7.0 (0.276)	1.3 (0.051)	1000
30	00 6208 500 030 600	29.0 (1.142)	35.4 (1.394)	36.4 (1.433)	3.9 (0.154)	5.5 (0.217)	7.0 (0.276)	1.3 (0.051)	900

HOW TO ORDER

00

6208

XXX

OXX

000

Variation Code

500 = SMT Without Boss
520 = SMT With Boss

Number of Contacts

NOTE - Elco standard for the 500 Variation Code is Tape and Reel, see page 60 to order.
- 26, 28 and 30 pin are only available without boss.
- and with wide slider, see page 60 to order in Tape and Reel.

1.00mm Pitch

Series 6208 - Tape and Reel Package

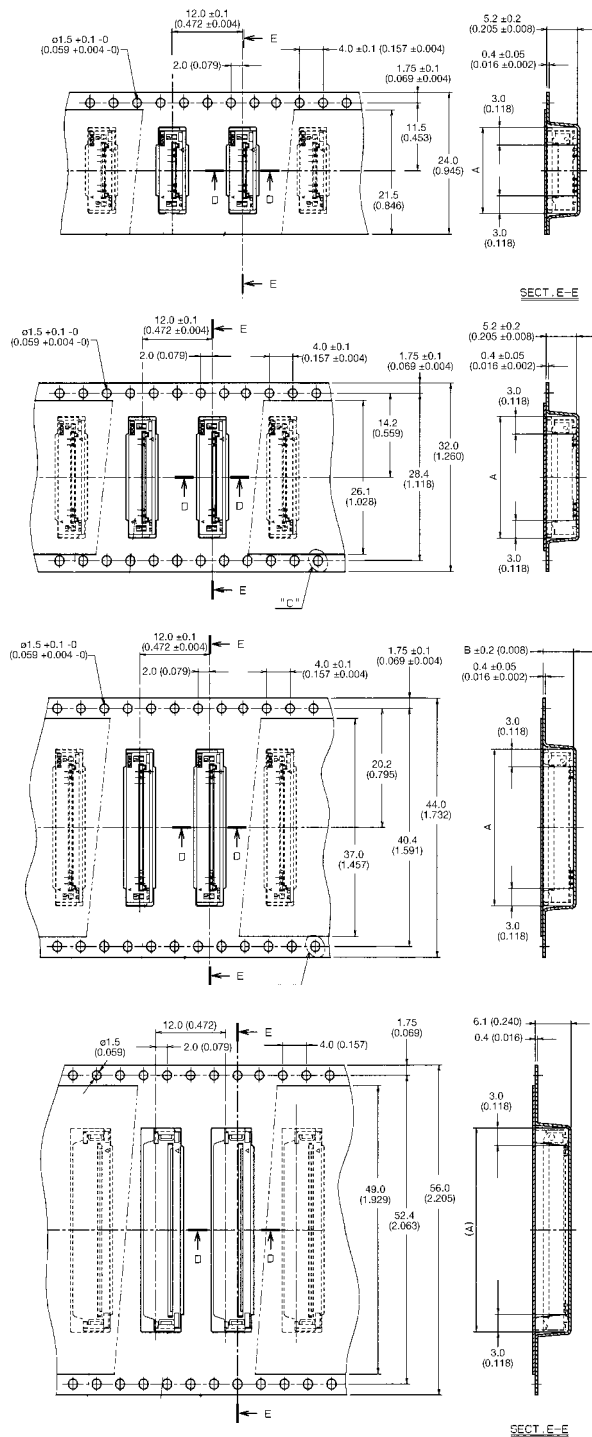

Assembly Number	No. of Contacts	A
00 6208 505 110 000	05	11.6 (0.457)
↑ 506 ↑	06	12.6 (0.496)
507	07	13.6 (0.535)
508	08	14.6 (0.575)
↓ 509 ↓	09	15.6 (0.614)
00 6208 510 110 000	10	16.6 (0.654)

Assembly Number	No. of Contacts	A
00 6208 511 210 000	11	17.6 (0.693)
↑ 512 ↑	12	18.6 (0.732)
513	13	19.6 (0.772)
514	14	20.6 (0.811)
↓ 515 ↓	15	21.6 (0.850)
00 6208 516 210 000	16	22.6 (0.890)

Assembly Number	No. of Contacts	A
00 6208 517 310 000	17	23.6 (0.929)
↑ 518 ↑	18	24.6 (0.969)
519	19	25.6 (1.008)
520	20	26.6 (1.047)
521	21	27.6 (1.087)
522	22	28.6 (1.126)
523	23	29.6 (1.165)
524	24	30.6 (1.205)
↓ 525 ↓	25	31.6 (1.244)
00 6208 526 310 000	26	32.6 (1.283)

Assembly Number	No. of Contacts	A
00 6208 528 410 006	28	34.7 (1.366)
00 6208 530 410 006	30	36.7 (1.445)

HOW TO ORDER

00

6208

5XX

X10

000

Number of Contacts

Variation Code

- 1 = Emboss 24.0mm
- 2 = Emboss 32.0mm
- 3 = Emboss 44.0mm
- 4 = Emboss 56.0mm

1000 Connectors per Tape and Reel.